

---

**TECHNICAL BULLETIN  
INSTALLATION INSTRUCTIONS  
FOR RETRANSMISSION VEHICLE WITH AMTECH TOP**

**FOR SYSTEMS**

**SINGLE CHANNEL GROUND AND AIRBORNE  
RADIO SYSTEM (SINGARS)  
AN/VRC-92F**

**FORCE XXI BATTLE COMMAND, BRIGADE-AND-BELOW (FBCB2)  
AN/UYK-128 (V)4**

**NEAR TERM DIGITAL RADIO (NTDR)  
RT-1812**

**ENHANCED POSITION LOCATION REPORTING SYSTEM (EPLRS)  
AN/VSQ-2 (V)**

**QUICK ERECT ANTENNA MOUNT (QEAM)  
AB-1386/U**

**DEFENSE ADVANCED GLOBAL POSITIONING SATELLITE RECEIVER (DAGR)**

**PRECISION LIGHTWEIGHT GPS RECEIVER (PLGR)  
AN/PSN-11**

**SUPPLEMENTAL BATTERIES**

**FOR VEHICLES**

**TRUCK, UTILITY, 2/4-DOOR: CARGO/TROOP CARRIER, 1-1/4 TON, 4X4,  
M998 (2320-01-107-7155) (EIC: BBD); M998A1 (2320-01-371-9577) (EIC: BBN);**

**TRUCK, UTILITY, 2/4-DOOR: HEAVY VARIANT, 1-1/4 TON, 4X4,  
M1097 (2320-01-346-9317) (EIC: BBM); M1097A1 (2320-01-371-9583) (EIC: BBU);  
M1097A2 (2320-01-380-8604) (EIC: BB6).**

**Approved for public release; distribution is unlimited.**

---

**HEADQUARTERS, DEPARTMENT OF THE ARMY**

**SEPTEMBER 2006**



**LIST OF EFFECTIVE PAGES**

**NOTE**

A vertical line in the outer margins of the page indicates the portion of text affected by the change.

Dates of issue for original and change pages are:

Original . . . . . 0 . . . . 29 September 2006

TOTAL NUMBER OF PAGES IN THIS PUBLICATION IS 155 PAGES.

Page No.	*Change No.
i-iii/iv (blank) . . . . .	.0
1-1 – 5-132 . . . . .	.0

\*Zero in this column indicates original page.



TECHNICAL BULLETIN  
NO. 9-2320-280-35-15

HEADQUARTERS,  
DEPARTMENT OF THE ARMY  
WASHINGTON, D.C., 29 SEPTEMBER 2006

**TECHNICAL BULLETIN INSTALLATION INSTRUCTIONS  
FOR RETRANSMISSION VEHICLE WITH AMTECH TOP**

**FOR SYSTEMS**

**SINGLE CHANNEL GROUND AND AIRBORNE RADIO SYSTEM (SINGARS)  
AN/VRC-92F**

**FORCE XXI BATTLE COMMAND, BRIGADE-AND-BELOW (FBCB2)  
AN/UYK-128 (V)4**

**NEAR TERM DIGITAL RADIO (NTDR)  
RT-1812**

**ENHANCED POSITION LOCATION REPORTING SYSTEM (EPLRS)  
AN/VSQ-2 (V)**

**QUICK ERECT ANTENNA MOUNT (QEAM)  
AB-1386/U**

**DEFENSE ADVANCED GLOBAL POSITIONING SATELLITE RECEIVER (DAGR)**

**PRECISION LIGHTWEIGHT GPS RECEIVER (PLGR)  
AN/PSN-11**

**SUPPLEMENTAL BATTERIES**

**FOR VEHICLES**

**TRUCK, UTILITY, 2/4-DOOR: CARGO/TROOP CARRIER, 1-1/4 TON, 4X4,  
M998 (2320-01-107-7155) (EIC: BBD); M998A1 (2320-01-371-9577) (EIC: BBN);**

**TRUCK, UTILITY, 2/4-DOOR: HEAVY VARIANT, 1-1/4 TON, 4X4,  
M1097 (2320-01-346-9317) (EIC: BBM); M1097A1 (2320-01-371-9583) (EIC: BBU);  
M1097A2 (2320-01-380-8604) (EIC: BB6).**

**REPORTING ERRORS AND RECOMMENDING IMPROVEMENTS**

You can help improve this publication. If you find any mistakes or if you know of a way to improve the procedures, please let us know. Submit your DA Form 2028 (Recommended Changes to Equipment Technical Publications), through the Internet, on the Army Electronic Product Support (AEPS) website. The Internet address is <https://aeprs.ria.army.mil>. The DA Form 2028 is located under the Public Applications section in the AEPS Public Home Page. Fill out the form and click on SUBMIT. Using this form on the AEPS will enable us to respond quicker to your comments and better manage the DA Form 2028 program. You may also mail, fax or E-mail your letter or DA Form 2028 direct to: AMSTA-LC-LPIT / TECH PUBS, TACOM-RI, 1 Rock Island Arsenal, Rock Island, IL 61299-7630. The email address is [TACOM-TECH-PUBS@ria.army.mil](mailto:TACOM-TECH-PUBS@ria.army.mil). The fax number is DSN 793-0726 or Commercial (309) 782-0726.

Approved for public release; distribution is unlimited.

**TABLE OF CONTENTS**

		<b>Page</b>
	LIST OF TABLES .....	iii
CHAPTER 1.	INTRODUCTION .....	1-1
Section I.	Scope .....	1-1
Section II.	Notes .....	1-1
Section III.	General Information .....	1-1
Section IV.	Maintenance Forms, Records, and Reports .....	1-1
Section V.	Consolidated Index of Army Publications .....	1-1
CHAPTER 2.	PURPOSE OF INSTALLATION .....	2-1
CHAPTER 3.	COMPLETION TIME FOR INSTALLATION .....	3-1
CHAPTER 4.	PREPARATION FOR INSTALLATION	4-1
Section I.	Preparation of Vehicle .....	4-1
Section II.	Items to be Removed .....	4-1
Section III.	List of Items to be Retained .....	4-1
Section IV.	Preparation of C4ISR Equipment .....	4-1
Section V.	Precautions During Handling .....	4-1
Section VI.	Unpack and Inspect Equipment .....	4-1
Section VII.	Inventory C4ISR Equipment .....	4-1
Section VIII.	Examine Each Item for Damage .....	4-2
Section IX.	C4ISR Equipment, Distribution, and Consumables .....	4-2
Section X.	Distribution and Issue Instructions .....	4-2
Section XI.	Parts List .....	4-2
CHAPTER 5.	INSTALLATION PROCEDURES	5-1
Section I.	Scope .....	5-1
Section II.	Installation of Terminal Boards .....	5-1
Section III.	Panel Modifications .....	5-1
Section IV.	Terminal Board, Cover, and Link Modification .....	5-3
Section V.	B-Beam Preparation .....	5-4
Section VI.	Assembly of Cab Enclosure Panel .....	5-5
Section VII.	Final Assembly, Terminal Board Wiring, and Terminal Link .....	5-6
Section VIII.	Integrated Rack Installation .....	5-11
Section IX.	Installation of SINCGARS Mounting Tray and Amp Guard .....	5-13
Section X.	Front Power Amplifier Installation .....	5-14
Section XI.	FBCB2 Components Installation .....	5-16
Section XII.	Serial Interface Adapter Device (SIAD) Cables Installation .....	5-18

**TABLE OF CONTENTS (Contd)**

		<b>Page</b>
Section XIII.	Serial Interface Adapter Device (SIAD) Installation . . . . .	5-19
Section XIV.	FBCB2 Cables Installation . . . . .	5-20
Section XV.	Loudspeaker and Multi-Net Rack Installation . . . . .	5-22
Section XVI.	Charge Control Box Installation . . . . .	5-27
Section XVII.	Lower Rear SINGARS Mount Installation . . . . .	5-28
Section XVIII.	Lower Rear Power Amplifier Installation . . . . .	5-30
Section XIX.	Charger Installation . . . . .	5-35
Section XX.	Upper Rear SINGARS Mount Installation . . . . .	5-37
Section XXI.	Power Amplifier Installation on Upper Shelf of Multi-Net Rack . . . . .	5-38
Section XXII.	NTDR Mounting . . . . .	5-41
Section XXIII.	Antenna Installation . . . . .	5-43
Section XXIV.	EPLRS Mounting Bracket Installation . . . . .	5-46
Section XXV.	SINGARS Pedestal Antenna Mount Installation . . . . .	5-49
Section XXVI.	EPLRS Pedestal Antenna Mount and NTDR Antenna Installation . . . . .	5-54
Section XXVII.	Power Entry Box Installation . . . . .	5-58
Section XXVIII.	EPLRS URO (User Readout) Installation . . . . .	5-59
Section XXIX.	Loudspeaker Installation on Windshield Frame . . . . .	5-60
Section XXX.	QEAM Mounting: Antennas and Brackets . . . . .	5-64
Section XXXI.	DAGR Bracket Installation . . . . .	5-70
Section XXXII.	PLGR Bracket Installation . . . . .	5-71
Section XXXIII.	Antenna and Cable Installation (Without Bolt-On Armor) . . . . .	5-72
Section XXXIV.	Armor and Antenna Installation (With Bolt-On Armor) . . . . .	5-78
Section XXXV.	Antenna Cable Routing (With Bolt-On Armor) . . . . .	5-80
Section XXXVI.	Loudspeaker Cables Installation on Multi-Net Rack . . . . .	5-84
Section XXXVII.	SINGARS Cables Installation . . . . .	5-88
Section XXXVIII.	SINGARS on Right-Side Pedestal Mount Cables Installation . . . . .	5-92
Section XXXIX.	EPLRS Cables and NTDR Antenna Cable Installation . . . . .	5-95
Section XL.	C4ISR Power Cables Installation . . . . .	5-100

**LIST OF TABLES**

<b>Table</b>	<b>Title</b>	<b>Page</b>
4-1.	Kits Parts List for Installation of C4ISR Equipment . . . . .	4-3
4-2.	Non-Kit Parts List for Installation of C4ISR Equipment . . . . .	4-5





# CHAPTER 1

## INTRODUCTION

### Section I. SCOPE

- 1-1.** This technical bulletin provides installation instructions for Command, Control, Communications, Computers, Intelligence, Surveillance, and Reconnaissance (C4ISR) equipment. The C4ISR equipment shall be installed in the following vehicles:
- a. Truck, Utility, 2/4-Door: Cargo/Troop Carrier, 1-1/4 Ton, 4x4, M998, M998A1
  - b. Truck, Utility, 2/4-Door: Heavy Variant, 1-1/4 Ton, 4x4, M1097, M1097A1, M1097A2
- 1-2.** The information contained in this technical bulletin is the official authorization to perform the installation of the C4ISR equipment at the direct support maintenance level through contract maintenance teams.

### Section II. NOTES

- 2-1.** This technical bulletin is not an authorization for requisition or turn-in of vehicles.
- 2-2.** This technical bulletin does not establish quantity or types of vehicles assigned to using units.

### Section III. GENERAL INFORMATION

- 3-1.** Included in the C4ISR equipment are:
- a. Single Channel Ground and Airborne Radio System (SINCGARS) AN/VRC-92F
  - b. Force XXI Battle Command, Brigade-and-Below (FBCB2) AN/UYK-128 (V)4
  - c. Near Term Digital Radio (NTDR) RT-1812
  - d. Enhanced Position Location Reporting System (EPLRS) AN/VSQ-2 (V)
  - e. Quick Erect Antenna Mount (QEAM) AB-1386/U
  - f. Defense Advanced Global Positioning Satellite Receiver (DAGR)
  - g. Precision Lightweight GPS Receiver (PLGR) AN/PSN-11
  - h. Supplemental batteries
  - i. Additional terminal boards
- 3-2.** The C4ISR equipment becomes operable when all the components are installed in the vehicle and correct power is supplied.

### Section IV. MAINTENANCE FORMS, RECORDS, AND REPORTS

Use the following to report any discrepancies:

- a. Reports of Maintenance and Unsatisfactory Equipment. See chapter 4, sections VI through VIII for information.
- b. Report of Packaging and Handling Deficiencies. See chapter 4, sections VI through VIII for information.
- c. Discrepancy in Transportation Deficiency Report (TDR) (SF361). See chapter 4, sections VI through VIII for information.

### Section V. CONSOLIDATED INDEX OF ARMY PUBLICATIONS

Refer to the latest issue of DA PAM 25-30 to determine whether there are new changes or additional publications pertaining to the C4ISR equipment.



## **CHAPTER 2**

### **PURPOSE OF INSTALLATION**

The purpose of installing the C4ISR equipment is to provide the primary means of integrating command and control systems.



## **CHAPTER 3**

### **COMPLETION TIME FOR INSTALLATION**

A total of 20 man hours are required for two personnel to install the C4ISR equipment. Typical vehicle downtime is 12 hours.



## CHAPTER 4 PREPARATION FOR INSTALLATION

### Section I. PREPARATION OF VEHICLE

Ensure that the site includes adequate lighting and a power source when drilling is required. Inspect the vehicle for damage that could affect installation. Have any such damage repaired before installing the C4ISR equipment.

### Section II. ITEMS TO BE REMOVED

- 2-1. Remove batteries. (Refer to TM 9-2320-280-20.)
- 2-2. Remove left- and right-hand rear door, as applicable. (Refer to TM 9-2320-280-20.)
- 2-3. Remove left- and right-hand rear cab enclosure panel, as applicable. (Refer to TM 9-2320-280-20.)
- 2-4. Remove center tunnel insulation, as applicable. (Refer to TM 9-2320-280-20.)
- 2-5. Remove standard radio rack. (Refer to TM 9-2320-280-20.)
- 2-6. Remove cargo bulkhead. (Refer to TM 9-2320-280-20.)

### Section III. LIST OF ITEMS TO BE RETAINED

- 3-1. Batteries.
- 3-2. Left- and right-hand rear cab enclosure panel (if applicable).
- 3-3. Left- and right-hand rear fixed door (if applicable).

### Section IV. PREPARATION OF C4ISR EQUIPMENT

Unpack, inspect, and check inventory.

### Section V. PRECAUTIONS DURING HANDLING

Observe the following precautions to prevent equipment damage.

- a. Keep dust covers in place on connectors.
- b. Do not disassemble or modify parts in the C4ISR equipment unless authorized to do so.
- c. Keep mounting hardware covered and protected until needed.

### Section VI. UNPACK AND INSPECT EQUIPMENT

- 6-1. Unpack and inspect packaging for evidence of damage.
- 6-2. Report any shipping damage on SF 364 Report of Discrepancy (ROD) as prescribed in AR 735-11-2/DLAR 4140.55/NAVMATINST 4355.73A/AFR 400-64/MCO 4430.F.

### Section VII. INVENTORY C4ISR EQUIPMENT

If any item is missing, fill out and forward Transportation Discrepancy Report (TDR) (SF 361) as described in AR 55-38/NAVSUPINST 4610.33C/AFR 75-18/MCO P4610.19D/DLAR 450015.

### Section VIII. EXAMINE EACH ITEM FOR DAMAGE

If any item is damaged, fill out and forward SF 364 Report of Discrepancy (ROD) as prescribed in AR 735-11-2/DLAR 4140.55/NAVMATINST 4355.73A/AFR 400-64/MCO 4430.F. All damages should be reported as prescribed by DA PAM 738-750, as contained in the Maintenance Management Update.

### Section IX. C4ISR EQUIPMENT, DISTRIBUTION, AND CONSUMABLES

- 9-1. Use table 4-1 to identify and inventory C4ISR equipment installation parts supplied in kits.
- 9-2. Use table 4-2 to identify and inventory C4ISR equipment installation parts not supplied in kits.

### Section X. DISTRIBUTION AND ISSUE INSTRUCTIONS

- 10-1. U.S. Forces: Do not requisition C4ISR equipment. It will be shipped automatically.
- 10-2. U.S. Army Depots: Requisition C4ISR equipment through supply channels.
- 10-3. Multiservice: Instructions shall be included for multiservice modifications.
- 10-4. MAP/MAS countries: Instructions shall be provided for MAP/MAS countries.

### Section XI. PARTS LIST

#### KITS REQUIRED FOR THIS INSTALLATION:

#### NOTE

- Not all material in kits is required for this installation. Material not used during installation will be returned to stock for disposition in accordance with AR 725-50.
- If maintenance is to be performed on a vehicle with an existing kit, do not order entire kit for necessary reinstallation.

#### SINGARS:

- (A): MK-2326
- (B): MK-2327
- (C): MK-2328

#### DAGR:

- (D): No kits available

#### PLGR:

- (E): 57K4400

#### EPLRS:

- (F): MK-2467A/VSQ-1

#### FBCB2:

- (G): No kits available

#### NTDR:

- (H): No kits available

#### QEAM:

- (J): No kits available

#### SUPPLEMENTAL BATTERIES:

- (K): No kits available



**MATERIAL REQUIRED FROM KITS:***Table 4-1. Kit Parts List for Installation of C4ISR Equipment.*

ITEM NO.	NOMENCLATURE	PART NUMBER	NSN	KIT	QTY.
1.	Bracket, Antenna	A3014546-1	5340-01-391-2742	(A),(B),(C)	2
2.	Bracket, Multiple Angle-Left	A3018371-1	5340-01-392-2217	(F)	1
3.	Bracket, Multiple Angle-Left	A3018372-1	5340-01-392-2216	(F)	1
4.	Bracket, Multiple Angle-Right	A3018371-2	5340-01-425-8010	(F)	1
5.	Bracket, Multiple Angle-Right	A3018372-2	5340-01-425-5600	(F)	1
6.	Bracket, PLGR Mount	12480578	N/A	(E)	1
7.	Cable Assembly, Antenna	A3014031-17	5995-01-225-1660	(B),(C)	1
8.	Cable Assembly, Antenna, EPLRS	SM-C-911480	5995-01-167-1269	(F)	1
9.	Cable Assembly, Power, EPLRS	A3004939	5995-01-198-0538	(F)	1
10.	Cable Assembly, Radio Frequency	A3014031-8	5995-01-219-7035	(A),(B),(C)	1
11.	Cable Assembly, Radio Frequency	A3014032-3	5995-01-219-7025	(B),(C)	1
12.	Clamp, Loop	MS21333-71	5340-00-057-2904	(A),(B),(C)	2
13.	Clamp, Loop	MS21333-75	5340-00-050-2740	(A),(B),(C)	1
14.	Clamp, Loop	MS21333-96	5340-00-088-1255	(E)	2
15.	Fiber Rope Assembly, Single Leg	A3167672-1	4020-01-341-8795	(A),(B),(C)	3
16.	Gasket	A3013655-1	5330-01-205-2864	(A),(B),(C),(F)	4
17.	Grommet	MS21266-4N	5325-00-923-9512	(B),(C),(D)	2
18.	Grommet	MS35489-31	5325-00-174-9336	(E)	2
19.	Grommet	MS35489-143	5325-00-292-7558	(E)	2
20.	Insert	12446871-2	5310-01-411-3422	(E)	2
21.	Loudspeaker	A3014065-1	5965-01-222-1420	(A),(B),(C)	6
22.	Mounting Base, Electrical Equipment	A3013367-1	5975-01-188-8873	(A),(B),(C)	3
23.	Mounting Base, Electrical Equipment	A3014053-1	5975-01-235-1962	(B),(C)	3
24.	Nut	MS35650-302	5310-00-934-9751	(A),(F)	1
25.	Nut	MS51967-2	5310-00-761-6882	(A),(B),(C),	11
26.	Nut	MS51968-5	5310-00-880-7746	(A),(B),(G)	2
27.	Nut	9419143	5310-01-148-0240	(E)	1
28.	Nut, Strip	A3014064-1	N/A	(B),(C),(D)	3
29.	Plate, Mounting	A3014550-1	N/A	(A),(B),(C),(D)	6
30.	Screw	MS35206-263	5305-00-984-6210	(E)	4
31.	Screw	MS35206-265	5305-00-984-6212	(E)	1
32.	Screw	MS35224-65	5310-00-543-5743	(F)	2
33.	Screw, Cap	B1821BH025C100N	5305-00-225-3843	(E)	3
34.	Screw, Cap	B1821BH025C125N	5305-00-068-0509	(E)	2

**MATERIAL REQUIRED FROM KITS (Contd):***Table 4-1. Kit Parts List for Installation of C4ISR Equipment (Contd).*

ITEM NO.	NOMENCLATURE	PART NUMBER	NSN	KIT	QTY.
35.	Screw, Cap	B1821BH025C175N	5305-00-071-2510	(E)	1
36.	Screw, Cap	MS35207-261	5305-00-990-6444	(E)	1
37.	Screw, Cap	MS35307-365	5305-00-847-1159	(A),(B),(C)	8
38.	Screw, Cap	MS90725-8	5305-00-225-3839	(A),(B),(C)	2
39.	Screw, Cap	MS90726-36	5305-00-225-9091	(A),(B),(C)	6
40.	Screw, Self-Tapping	9416639	5305-01-197-2320	(E)	1
41.	Screw, Self-Tapping	9421073	5305-01-162-8512	(E)	3
42.	Strap, Tiedown	MS3367-1-0	5975-00-984-6582	(E)	2
43.	Terminal, Lug	7728777	5940-00-983-4067	(E)	1
44.	Terminal, Lug	7728780	5940-01-035-4212	(E)	1
45.	Washer	MS27183-10	5310-00-809-4058	(B),(C)	11
46.	Washer	2436161	5310-01-102-3270	(C),(E)	6
47.	Washer, Lock	MS35338-43	5310-00-045-3296	(A),(E),(F)	4
48.	Washer, Lock	MS35338-44	5310-00-582-5965	(A),(B),(C),	34
49.	Washer, Lock	MS35338-46	5310-00-637-9541	(B),(C)	2
50.	Washer, Lock	MS35338-48	5310-00-584-5272	(B),(C),(D)	3
51.	Washer, Lock	MS45904-68	5310-00-889-2528	(A),(B)	5
52.	Washer, Lock	MS45904-72	5310-00-889-2527	(A),(B),(C),(F)	50
53.	Washer, Lock	MS45904-76	5310-00-061-1258	(C)	16
54.	Wellnut	12339397-3	5310-01-231-7455	(E)	1
55.	Wellnut	12339397-6	5310-01-388-6205	(E)	1

**MATERIAL REQUIRED BUT NOT INCLUDED IN KITS:***Table 4-2. Non-Kit Parts List for Installation of C4ISR Equipment.*

ITEM NO.	NOMENCLATURE	PART NUMBER	NSN	QTY.
1.	Antenna	A3005031	5820-01-183-9462	2
2.	Antenna AS-3900/VRC	A3017889-2	5985-01-308-8988	2
3.	Antenna Element (lower)	A3018230-1	5985-01-201-1498	3
4.	Antenna Element (upper)	A3017901-2	5985-01-306-4622	3
5.	Antenna, PLGR	AT575-030	5985-01-375-4660	1
6.	Bar, Aluminum, Flat	03A016D-2	N/A	1
7.	Bolt	MS35751-18	5306-00-108-9988	4
8.	Brace	A3046237	5340-01-262-9566	1
9.	Bracket, Antenna Base, Reinforcement	A3018372-1	5340-01-392-2216	1
10.	Bracket, Antenna Base Reinforcement	A3018372-2	5340-01-425-5600	1
11.	Bracket, Antenna Mounting	A3018371-2	5340-01-425-8010	1
12.	Bracket, PLGR	986-0645-001	5975-01-375-1302	1
13.	Bracket, Radio Rack	A3046235	5342-01-262-9563	2
14.	Bracket, User Readout (URO)	A3006206	5340-01-386-7841	1
15.	Cable Assembly, Antenna, PLGR	426-0141-050	6150-01-375-8662	1
16.	Cable Assembly, Ground	12480567-1	N/A	1
17.	Cable Assembly, INC-EPUU	A3279383-3	5995-01-453-9171	1
18.	Cable Assembly, Power, NTDR	8174912-2	N/A	1
19.	Cable Assembly, Power	A3154857-1	5995-01-438-7822	3
20.	Cable Assembly, Power	12480567-2	N/A	1
21.	Cable Assembly, Power, PLGR	9728558-10	6150-01-375-8661	1
22.	Cable Assembly, Power, SINCGARS	A3014039-2	5995-01-219-1843	2
23.	Cable Assembly, Power, SINCGARS	A3014039-7	5995-01-336-6933	1
24.	Cable Assembly, User Readout (URO)	A3005328	5995-01-375-2439	1
25.	Cable (Battery to Shunt)	RCSK-19638	N/A	1
26.	Cable (Battery to Solenoid)	RCSK-19637	N/A	1
27.	Cable, Control	A3210672-1	5995-01-444-7933	3
28.	Cable, Control Box, Green	N/A	N/A	1
29.	Cable, Control Box, Orange	N/A	N/A	1
30.	Cable, Control Box, Red	N/A	N/A	1
31.	Cable, Control, Large	03A0112D	N/A	1
32.	Cable (Shunt to Rear Battery)	RCSK-19644	A/R	1
33.	Cable (Solenoid to Rear Battery)	RCSK-19643	A/R	1
34.	Cable, Speaker	A3014038-3	5995-01-219-4704	6
35.	Cable, W1	866003-3	5995-01-478-4908	1
36.	Cable, W2	881327-1	5995-01-478-4876	1
37.	Cable, W3N	881336-1	5995-01-478-4913	1
38.	Cable, W3P	881335-1	5995-01-478-4891	1
39.	Charge Control Box	PKMM 000-002	A/R	1
40.	Clamp, Loop	MS21333-65	5340-00-905-0790	12

**MATERIAL REQUIRED BUT NOT INCLUDED IN KITS (Contd):***Table 4-2. Non-Kit Parts List for Installation of C4ISR Equipment (Contd).*

ITEM NO.	NOMENCLATURE	PART NUMBER	NSN	QTY.
41.	Clamp, Loop	MS21333-69	5340-00-764-7051	7
42.	Clamp, Loop	MS21333-67	5340-00-079-7837	1
43.	Clamp, Loop	MS21333-71	5340-00-057-2904	3
44.	Clamp, Loop	MS21333-75	5340-00-050-2740	3
45.	Clamp, Loop	MS21333-77	5340-00-922-6300	14
46.	Clamp, Loop	MS21333-96	5340-00-088-1255	3
47.	Clamp, Loop	MS21333-98	5340-00-809-1490	1
48.	Clamp, Loop	MS21333-102	5340-00-984-8540	4
49.	Clamp Subassembly	04A0010D	N/A	4
50.	Cover, Terminal	MS18029-IL-16	N/A	1
51.	CPU (Central Processing Unit)	881292-1	7021-01-474-3793	1
52.	Decal	12339060	7690-01-265-1135	1
53.	Decal	861868-2	N/A	1
54.	Display	881293-1	7025-01-475-0229	1
55.	Display Lock Assembly	872843-1	N/A	1
56.	Frame	A3210675-1	N/A	1
57.	Grommet	MS21266-1N	5325-00-960-2410	A/R
58.	Grommet	MS21266-4N	5325-00-923-9512	A/R
59.	Grommet	MS21266-6N	5325-00-783-4753	A/R
60.	Grommet	MS35489-31	5325-00-174-9336	1
61.	Grommet	12338098	5325-01-308-5424	2
62.	Grommet	2400	5325-01-289-7859	1
63.	Guard, Amp	872842-1	5935-01-487-2172	1
64.	Insert	12446871-2	5310-01-411-3422	15
65.	Isolation Kit, CPU	872826-2	5340-01-481-5741	1
66.	Isolation Kit, Display	872870-1	5340-01-481-5757	1
67.	J-Bolt	03A0103D	N/A	1
68.	Lanyard	8925T5-7X19	4010-01-497-2675	1
69.	Mounting Bracket, Antenna	A3018371-1	5340-01-392-2217	1
70.	Mount, Ramball	RAM-D-111U	5975-01-485-3615	1
71.	Mount, Resilient	MT-6146/VSQ-1	5340-01-167-8297	1
72.	Nut	MS35649-2252	5310-00-997-1888	3
73.	Nut	MS35649-2382	5310-00-056-3395	2
74.	Nut	MS35649-63	5310-00-804-3859	5
75.	Nut	MS35650-302	5310-00-934-9751	4
76.	Nut	MS51967-2	5310-01-102-7358	24
77.	Nut	MS51967-5	5310-01-478-3126	18
78.	Nut	MS51968-5	5310-00-880-7746	2
79.	Nut	13218E0320-293	5310-00-913-8881	22
80.	Nut	9417954	5310-00-931-8167	8

**MATERIAL REQUIRED BUT NOT INCLUDED IN KITS (Contd):***Table 4-2. Non-Kit Parts List for Installation of CAISR Equipment (Contd).*

ITEM NO.	NOMENCLATURE	PART NUMBER	NSN	QTY.
81.	Nut	9418892	5310-01-157-9819	10
82.	Nut	9419143	5310-01-148-0240	51
83.	Nut	9422771	5310-01-211-0691	2
84.	Nut, Lock	MS17829-4C	5310-01-465-0863	6
85.	Nut, Lock	MS17829-5C	5310-00-245-3424	4
86.	Nut, Lock	MS21044-N08	N/A	1
87.	Nut, Lock	271175	5310-01-333-5245	4
88.	Nut, Plain-Assembled	271169	5310-00-124-9265	5
89.	Panel, Enclosure	12447141	2510-01-413-5993	1
90.	Plate, Antenna	A3104004-1	N/A	1
91.	Plate, Antenna	A3104004-2	N/A	1
92.	Plate, Antenna	A3157619	9515-01-374-7165	2
93.	Plate, Backing	03A0101D	N/A	2
94.	Plate, Backing	03A0102D	N/A	2
95.	Plate, Battery Hold-Down	03A0103D	N/A	1
96.	Plate, Battery Support	03A0103D-1	N/A	1
97.	Plate, Placement	A3046203	5365-01-237-8104	1
98.	Power Entry Box	03A0108D	N/A	1
99.	Rack, Integrated	A3276903	N/A	1
100.	Rack, QEAM	PKMM-000-006	N/A	1
101.	Rivet	AB4-5A	5320-00-052-1972	15
102.	Rivet, Blind	12339355-1	5320-01-271-6357	2
103.	Screw	MS35206-247	5305-00-984-6195	2
104.	Screw	MS35206-230	5305-00-889-3000	5
105.	Screw	160035	5305-00-016-0035	1
106.	Screw	MS35190-291	5305-00-958-5247	2
107.	Screw	MS35207-265	5305-00-993-1848	4
108.	Screw	MS90726-36	5305-00-225-9091	18
109.	Screw, Cap	B1821BH025C075N	5305-00-068-0508	14
110.	Screw, Cap	B1821BH025C100N	5305-00-225-3843	50
111.	Screw, Cap	B1821BH025C125N	5305-00-068-0509	19
112.	Screw, Cap	B1821BH025C150N	5305-00-071-2509	14
113.	Screw, Cap	B1821BH031C100N	5306-00-226-4827	8
114.	Screw, Cap	B1821BH031F075N	5306-00-050-1238	6
115.	Screw, Cap	B1821BH031F100N	5305-00-051-4076	6
116.	Screw, Cap	B1821BH031C125N	5306-00-226-4829	2
117.	Screw, Cap	B1821BH031F125N	5305-00-051-4078	17
118.	Screw, Cap	B1821BH038F100N	5305-00-269-3236	6
119.	Screw, Cap	B1821BH038C150N	5305-00-725-2317	8
120.	Screw, Cap	B1821BH038F175N	5305-00-269-3241	4

**MATERIAL REQUIRED BUT NOT INCLUDED IN KITS (Contd):***Table 4-2. Non-Kit Parts List for Installation of C4ISR Equipment (Contd).*

ITEM NO.	NOMENCLATURE	PART NUMBER	NSN	QTY.
121.	Screw, Cap	B1821BH038C225N	5305-01-434-2947	2
122.	Screw, Cap	B1821BH044C125N	5305-00-071-1788	4
123.	Screw, Cap	B1821BH044C150N	5305-00-071-2055	2
124.	Screw, Cap	B1821BH050C400N	5305-00-071-2079	3
125.	Screw, Cap	B1821BH050C450N	5305-00-071-2081	2
126.	Screw, Cap	MS90725-8	5305-00-225-3839	2
127.	Screw, Cap	MS90726-36	5305-00-225-9091	5
128.	Screw, Self-Tapping	12342499-2	5305-01-264-5809	7
129.	Screw, Self-Tapping	9416639	5305-01-197-2320	1
130.	Screw, Self-Tapping	9421073	5305-01-162-8512	40
131.	Screw, Self-Tapping	9426241	5305-01-206-7219	1
132.	Screw, Self-Tapping	9426634	4320-00-570-6117	4
133.	Serial Interface Adapter Device	881331-1	4920-01-478-3722	1
134.	Sheet, Rubber	03A016D-1	N/A	1
135.	Shelf, Electrical	A3046236	5975-01-262-9575	2
136.	Shunt	PKMM 000-013	N/A	1
137.	Solenoid	586-905	5945-01-411-7621	1
138.	Spacer	A3046313	5820-01-237-8096	4
139.	Spacer	10705AL315C	5365-01-487-3145	4
140.	Spacer	92510A318	N/A	4
141.	Step, Folding	2797AZN	N/A	2
142.	Strap, Ground	7147-1167-3	N/A	2
143.	Strap, Tiedown	MS3367-1-0	5975-00-984-6582	A/R
144.	Tape, Electrical	HH-I-595	N/A	A/R
145.	Terminal Board	MS27212-1-23	N/A	1
146.	Terminal Board	MS27212-3-8	5940-00-950-7782	1
147.	Terminal Board	12480570	N/A	1
148.	Terminal Board Cover	MS18029-3S-2	5940-01-280-9304	1
149.	Terminal Board Cover	12480569-1	N/A	1
150.	Terminal Board Cover	12480569-2	N/A	1
151.	Terminal Link	MS25226-6N-2	6150-01-167-9267	1
152.	Terminal Lug	MS20659-108	5940-00-115-2674	2
153.	Terminal Lug	MS20659-129	5940-00-114-1314	2
154.	Terminal Lug	MS20659-141	5940-00-113-9825	4
155.	Terminal Lug	7728777	5940-00-983-4067	1
156.	Tray, Mounting	8174934G1	N/A	1
157.	Tubing, Convolutd	Z52-0013-001	N/A	1
158.	Tubing, Shrink	MS23053/4-302-0	5970-01-161-6796	A/R
159.	Washer	MS27183-3	5310-00-951-4679	3
160.	Washer	MS27183-8	5310-00-809-8546	8
161.	Washer	MS27183-10	5310-00-809-4058	22

**MATERIAL REQUIRED BUT NOT INCLUDED IN KITS (Contd):***Table 4-2. Non-Kit Parts List for Installation of C4ISR Equipment (Contd).*

ITEM NO.	NOMENCLATURE	PART NUMBER	NSN	QTY.
162.	Washer	MS27183-12	5310-00-081-4219	2
163.	Washer	MS27183-14	5310-00-462-9122	4
164.	Washer	MS27183-41	N/A	2
165.	Washer	MS51412-23	5310-01-333-0060	2
166.	Washer	12338095	5310-01-208-7576	2
167.	Washer	2436161	5310-01-102-3270	112
168.	Washer	2436163	5310-01-412-4013	2
169.	Washer	2436165	5310-01-121-1703	5
170.	Washer	9417373	5310-01-361-1163	1
171.	Washer, Lock	MS35338-41	5310-00-045-4007	5
172.	Washer, Lock	MS35338-44	5310-00-582-5965	93
173.	Washer, Lock	MS35338-46	5310-00-637-9541	6
174.	Washer, Lock	MS45904-68	5310-00-889-2528	6
175.	Washer, Lock	MS45904-72	5310-00-889-2527	72
176.	Washer, Lock	MS45904-76	5310-00-061-1258	2
177.	Washer, Lock	MS45904-84	5310-00-935-8984	5
178.	Washer, Lock	120380	5310-00-543-2705	5
179.	Washer, Lock	120382	5310-00-774-7293	6
180.	Wingnut	MS51553-420	5310-01-384-2546	4
181.	Wire Assembly, Fuse (12V)	12480568-2	N/A	1
182.	Wire Assembly, Fuse (24V)	12480568-1	N/A	3
183.	Wire, Braided	AA59569F30T0375	6145-00-191-8402	A/R
184.	Wire, Lock	MS20995C32	9505-00-293-4208	A/R





## CHAPTER 5 INSTALLATION PROCEDURES

### Section I. SCOPE

This chapter provides instructions for installation of C4ISR items in the vehicle. When installing C4ISR equipment, be sure to read and follow instructions and illustrations carefully.

### Section II. INSTALLATION OF TERMINAL BOARDS

Use the following procedure to install additional terminal boards to provide adequate power connections.

### Section III. PANEL MODIFICATIONS

#### NOTE

- For vehicles without cab enclosure panel, begin with step 3-1 and use cab enclosure panel NSN 2510-01-413-5993.
  - For vehicles with cab enclosure panel, begin with step 3-3.
  - All dimensions are in inches.
- 3-1.** Place cab enclosure panel (3) in position. Locate, mark, and drill five 0.159-in. diameter holes marked A and B in B-beam (1) and battery box (2).
- 3-2.** Enlarge two lower mounting holes marked A to 0.390-in. diameter, and install two inserts (4) in battery box (2).

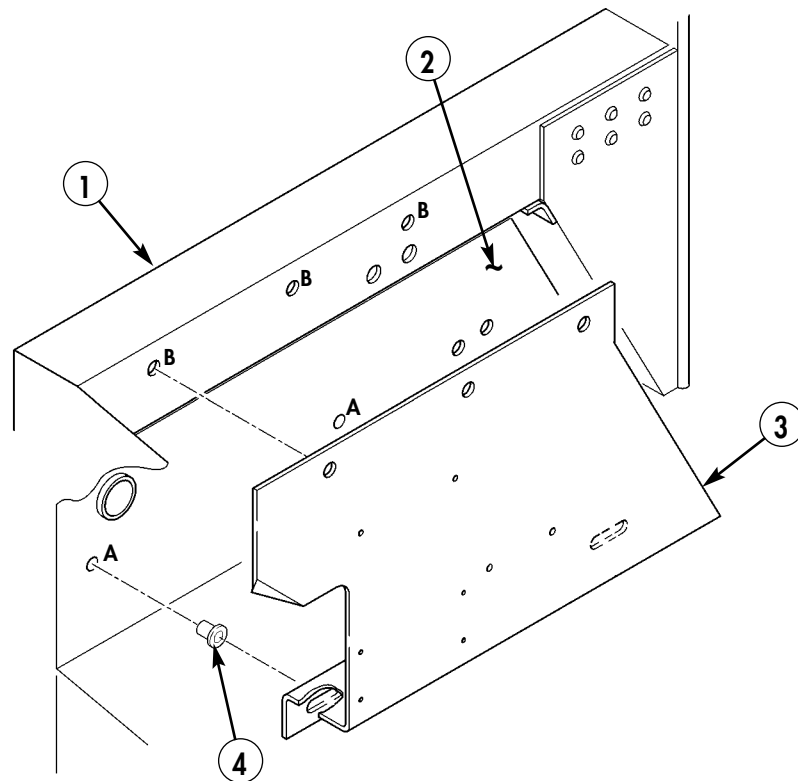

- 3. CAB ENCLOSURE PANEL – 12447141 – QTY. 1**  
**4. INSERT – 12446871-2 – QTY. 2**

*Figure 5-1.*

**NOTE**

Do not install cab enclosure panel.

- 3-3. Locate, mark, and drill three 0.156-in. diameter holes marked A in cab enclosure panel (1).
- 3-4. Locate, mark, and drill two 0.156-in. diameter holes marked C in cab enclosure panel (1).
- 3-5. Locate, mark, and drill two 0.196-in. diameter holes marked B in cab enclosure panel (1).

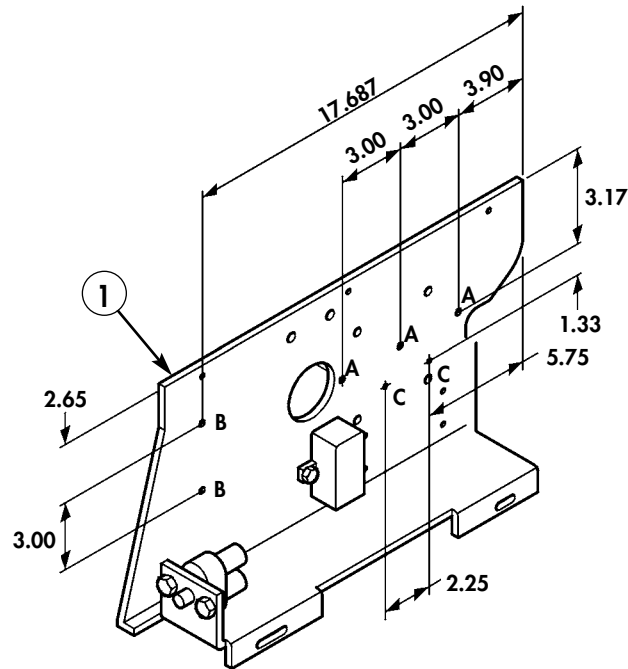

Figure 5-2.

### Section IV. TERMINAL BOARD, COVER, AND LINK MODIFICATION

#### **CAUTION**

Do not cut raised sections of terminal board. Terminal board is not usable if cut on raised section.

- 4-1. Measure and cut terminal board (1) in two places (2). Remove burrs and sharp edges.
- 4-2. Install five nut sleeves (5) in terminal board covers (3), (4), and (6) and secure with snaprings (7).

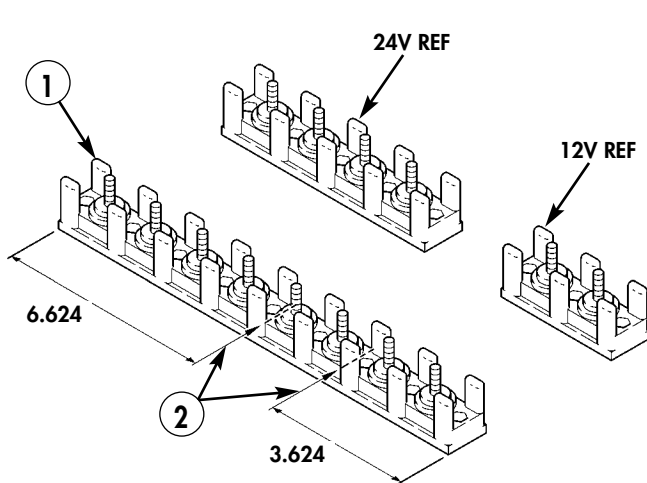

Figure 5-3.

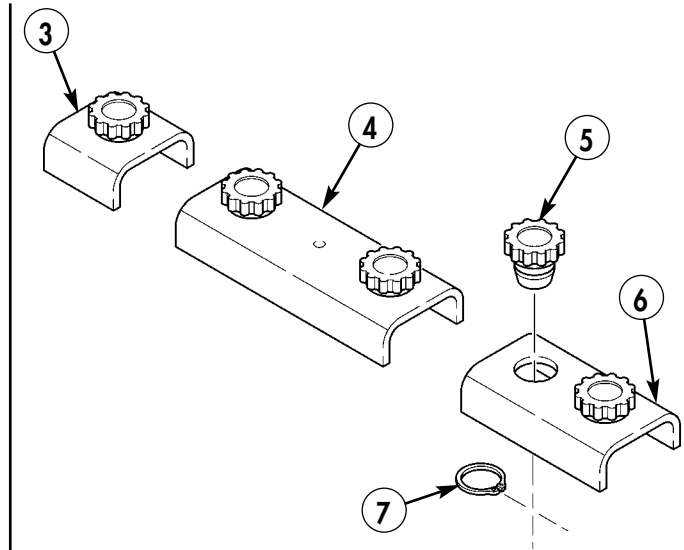

Figure 5-4.

- 1. TERMINAL BOARD – MS27212-3-8 – QTY. 1
- 3. TERMINAL BOARD COVER – 12480569-1 – QTY. 1
- 4. TERMINAL BOARD COVER – 12480569-2 – QTY. 1
- 6. TERMINAL BOARD COVER – MS18029-3S-2 – QTY. 1

### Section V. B-BEAM PREPARATION

Locate, mark, and drill four 0.159-in. diameter holes (2) in B-beam (1).

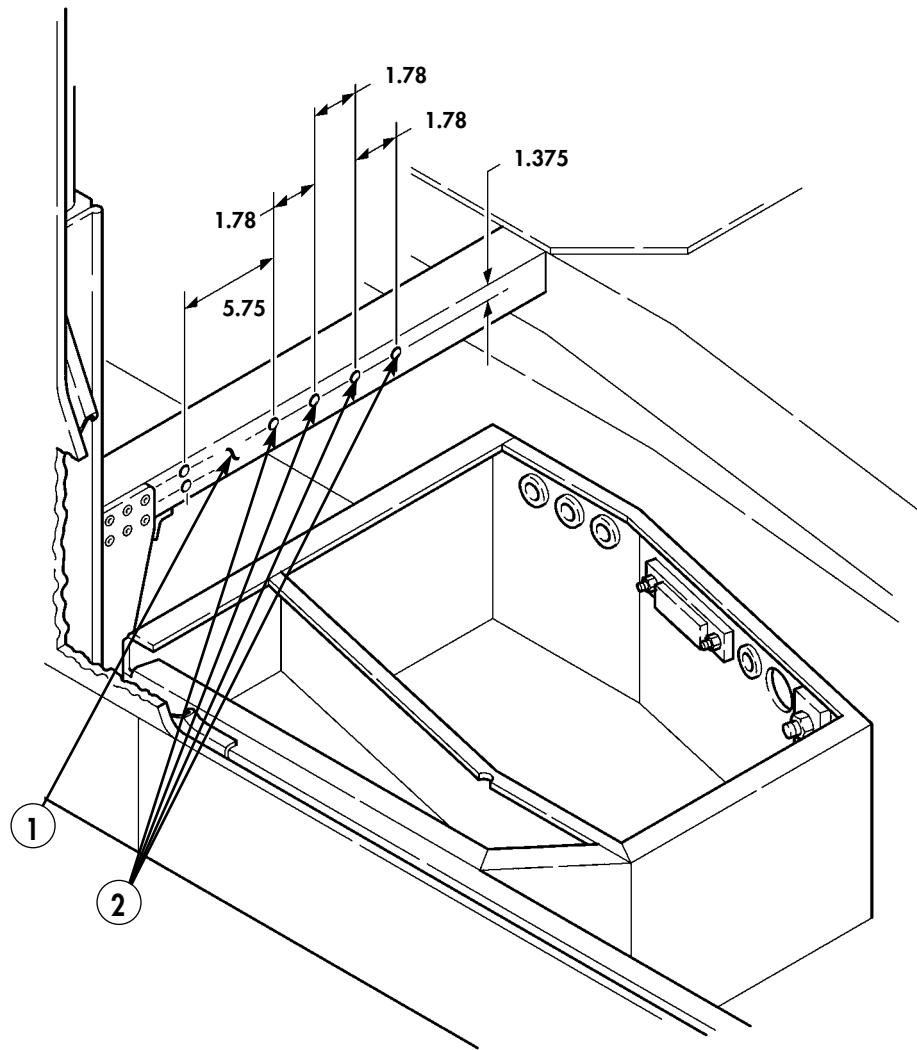
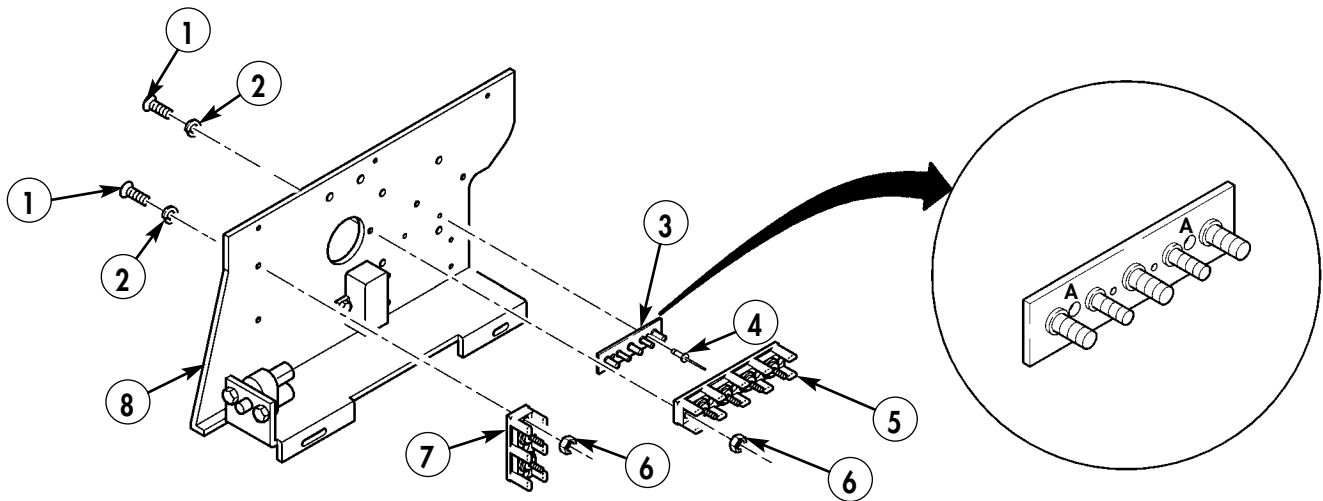

Figure 5-5.

## Section VI. ASSEMBLY OF CAB ENCLOSURE PANEL

- 6-1.** Install 12V terminal board (7) on enclosure panel (8) with two screws (1), lockwashers (2), and nuts (6).
- 6-2.** Install 24V terminal board (5) on enclosure panel (8) with three screws (1), lockwashers (2), and nuts (6).
- 6-3.** Enlarge two holes marked A in terminal board (3) to 0.196 in., and secure terminal board (3) to cab enclosure panel (8) with two rivets (4).



- 1.** SCREW – MS35206-230 – QTY. 5
- 2.** LOCKWASHER – MS35338-41 – QTY. 5
- 3.** TERMINAL BOARD – 12480570 – QTY. 1
- 4.** BLIND RIVET – 12339355-1 – QTY. 2
- 6.** NUT – MS35649-63 – QTY. 5

Figure 5-6.

## Section VII. FINAL ASSEMBLY, TERMINAL BOARD WIRING, AND TERMINAL LINK

### NOTE

Perform steps 7-1 and 7-2 if hole does not exist in battery box.

- 7-1. Locate, mark, and drill one 2.00-in. diameter hole (6) in upper right corner of rear wall of battery box (9).
- 7-2. Install rubber grommet (7) in hole (6).
- 7-3. Secure terminal link (2) and fuse wire (3) to 12V terminal board (1) with two locknuts (4), and install terminal board cover (5).
- 7-4. Route 11.00-in. wire (8) through battery box hole (6).

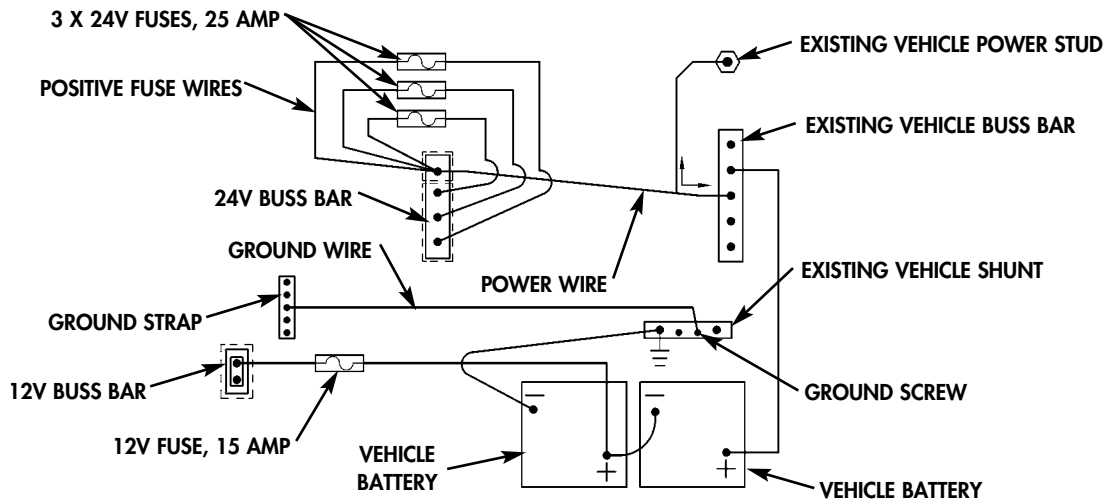
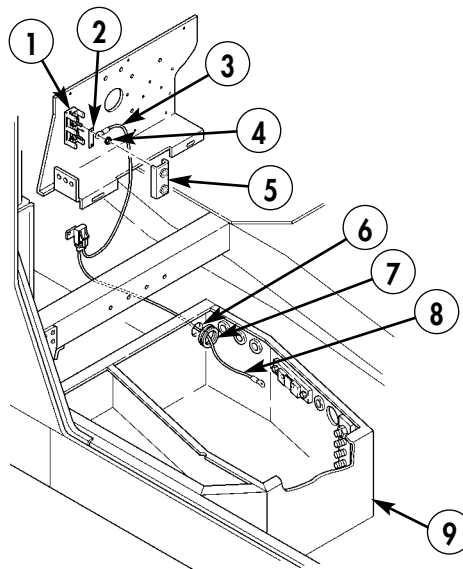

Figure 5-7.



2. TERMINAL LINK - MS25226-6N-2 - QTY. 1
3. FUSE WIRE ASSEMBLY (12V) - 12480568-2 - QTY. 1
4. LOCKNUT - 271175 - QTY. 2
7. GROMMET - 2400 - QTY. 1

Figure 5-8.

- 7-5. Connect wire (8) to existing positive 12V battery terminal end (11) with existing screw (10) and nut (12).

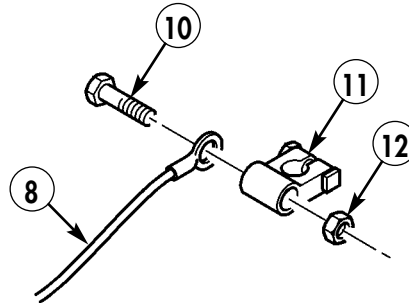
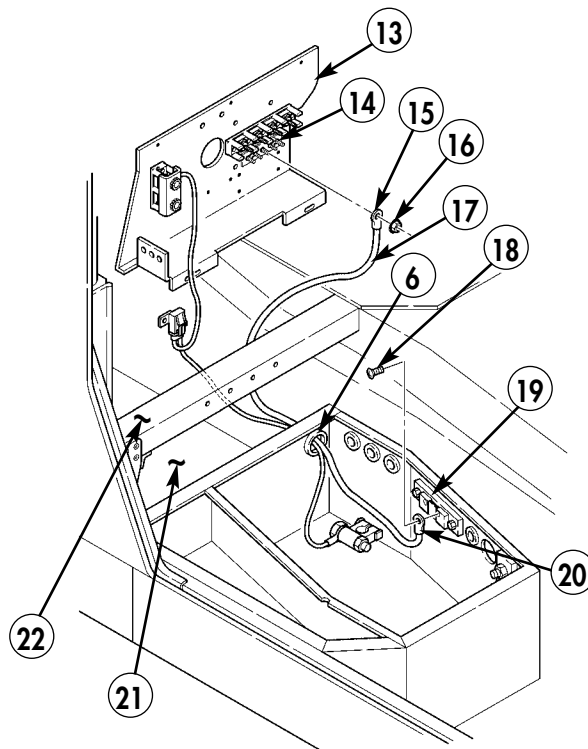

Figure 5-9.

- 7-6. Position cab enclosure panel (13) in rear floor pan (21) and rear of B-beam (22). Do not secure cab enclosure panel (13) at this time.
- 7-7. Route ground cable (17) through battery box hole (6).
- 7-8. Secure terminal lug (15) to center terminal of terminal board (14) with nut (16), and secure terminal lug (20) to shunt (19) with existing screw (18).
- 7-9. Install four additional nuts (16) on terminal board (14).



16. PLAIN-ASSEMBLED NUT – 271169 – QTY. 5  
 17. GROUND CABLE ASSEMBLY – 12480567-1 – QTY. 1

Figure 5-10.

- 7-10. Route 24V power cable (28) through hole (6) and install 24V power cable terminal lug (24) on inboard stud (23) of terminal board (29). Do not secure 24V power cable terminal lug (24) at this time.
- 7-11. Secure three fuse wires (26) and 24V power cable terminal lug (24) to inboard terminal board stud (23) with locknut (27).
- 7-12. Secure three remaining fuse wires (25) to corresponding studs on 24V terminal board (29) with three locknuts (27).

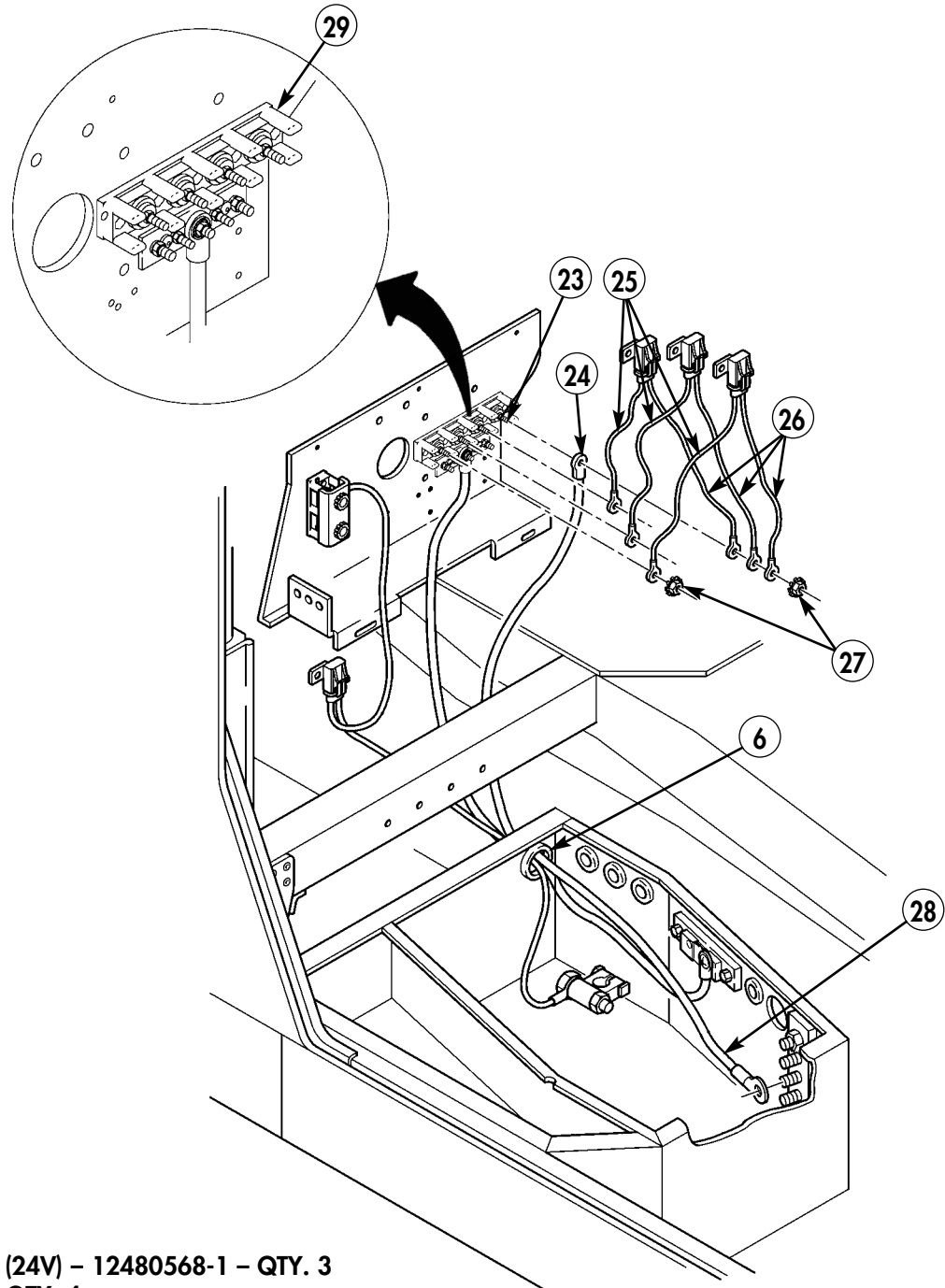

- 25. FUSE WIRE ASSEMBLY (24V) – 12480568-1 – QTY. 3
- 27. LOCKNUT – 271175 – QTY. 4
- 28. POWER CABLE ASSEMBLY – 12480567-2 – QTY. 1

Figure 5-11.



**NOTE**

For vehicles with new cab enclosure panel, begin with step 7-14.

- 7-13. Install cab enclosure panel (13). (Refer to TM 9-2320-280-20.)
- 7-14. Secure cab enclosure panel (13) to B-beam (22) with three self-tapping screws (30).
- 7-15. Secure cab enclosure panel (13) to battery box (34) with two capscrews (31), lockwashers (32), and washers (33).

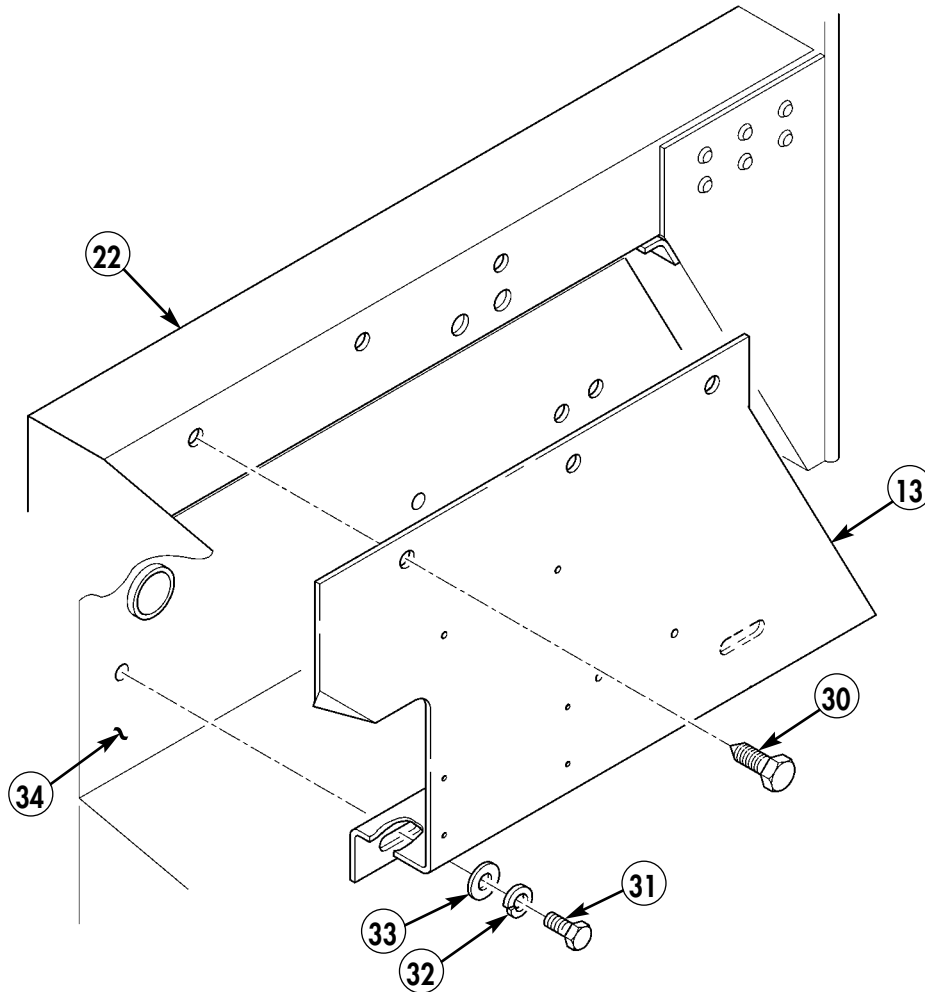

- 30. SELF-TAPPING SCREW – 12342499-2 – QTY. 3
- 31. CAPSCREW – B1821BH025C075N – QTY. 2
- 32. LOCKWASHER – MS35338-48 – QTY. 2
- 33. FLAT WASHER – MS51412-23 – QTY. 2

Figure 5-12.

- 7-16. Secure three 24V fuse wire assemblies (25) and one 12V fuse wire assembly (3) to B-beam (22) with four self-tapping screws (36).

**NOTE**

For models equipped with power stud, perform step 7-17.  
Otherwise, proceed to step 7-18.

- 7-17. Secure 24V terminal board power wire terminal lug (28) to power stud (40) with lockwasher (38) and existing nut (39).
- 7-18. Secure 24V terminal board power wire terminal lug (28) to terminal board (37) with lockwasher (38) and existing nut (39).
- 7-19. Install decal (35) on B-beam (22).
- 7-20. If previously removed, install right-hand rear fixed door. (Refer to TM 9-2320-280-20.)
- 7-21. Install batteries. (Refer to TM 9-2320-280-20.)

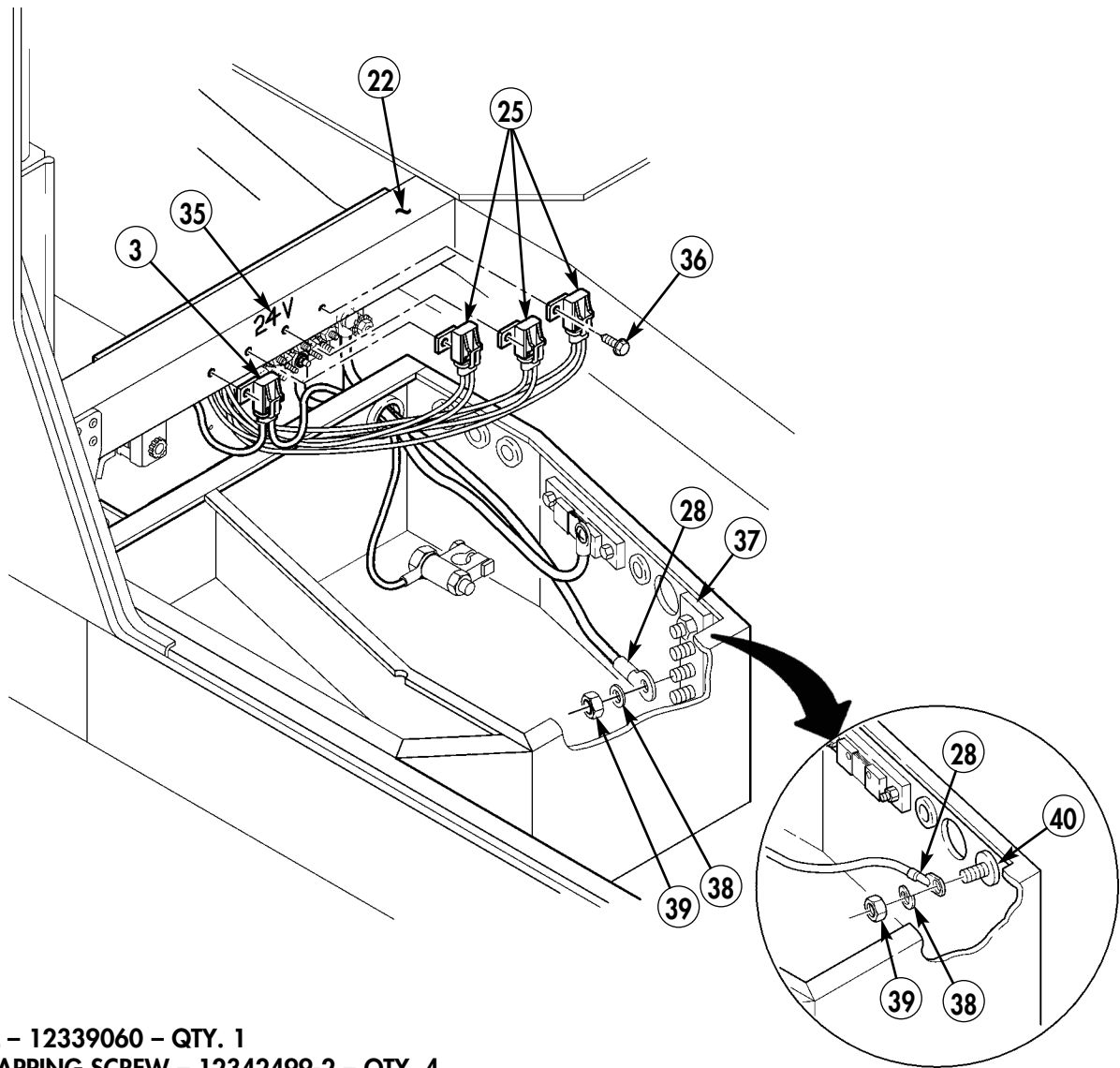

- 35. DECAL – 12339060 – QTY. 1
- 36. SELF-TAPPING SCREW – 12342499-2 – QTY. 4
- 38. LOCKWASHER – MS35338-48 – QTY. 1

Figure 5-13.

## Section VIII. INTEGRATED RACK INSTALLATION

- 8-1. Remove two inserts (2) from bottom of integrated rack (1).

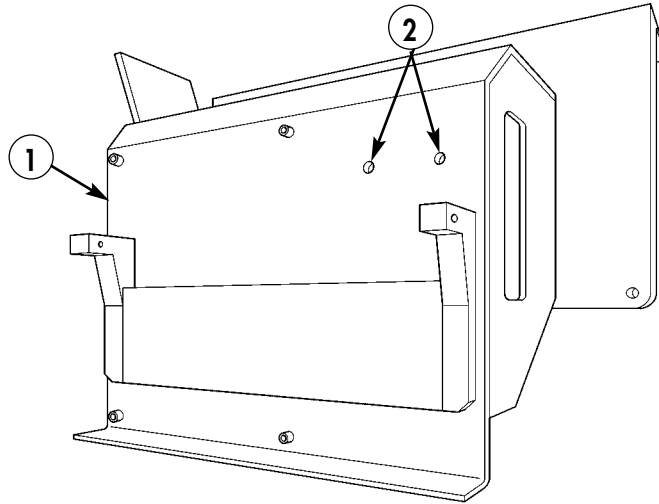

1. RACK, INTEGRATED – A3276903 – QTY. 1

*Figure 5-14.*

- 8-2. Using integrated rack (1) as template, locate, mark, and drill one 0.390-in. diameter hole (4) in dash (6).
- 8-3. Remove paint from vicinity of hole (4) and two existing inserts (5).
- 8-4. Install insert (3) in hole (4).
- 8-5. Apply anti-seize compound to vicinity of inserts (3) and (5) as required.

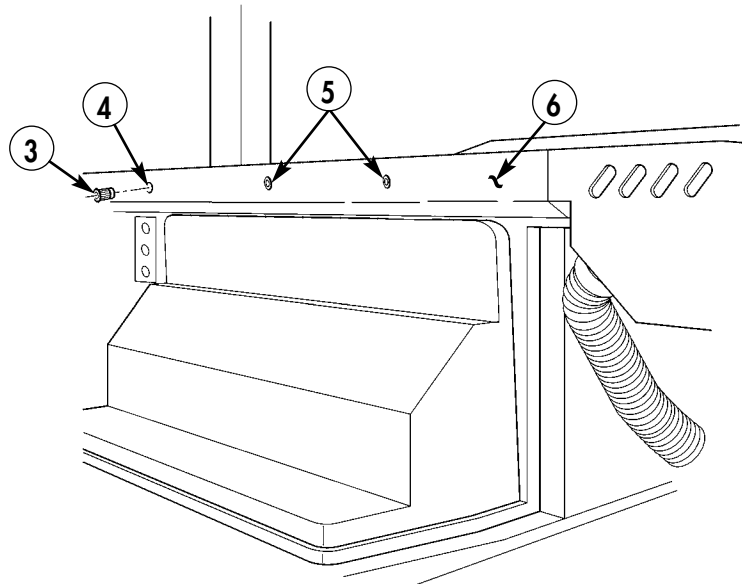

3. INSERT – 12446871-2 – QTY. 1

*Figure 5-15.*

- 8-6. Remove paint from vicinity of three mounting slots (7) on integrated rack (1).
- 8-7. Apply anti-seize compound to vicinity of three mounting slots (7) on integrated rack (1) as required.

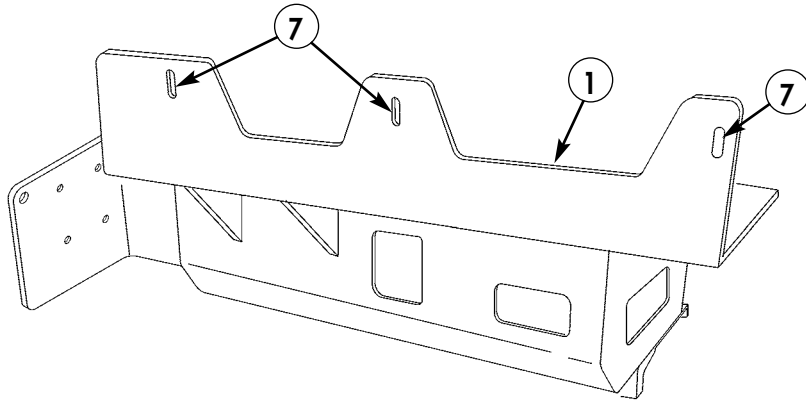
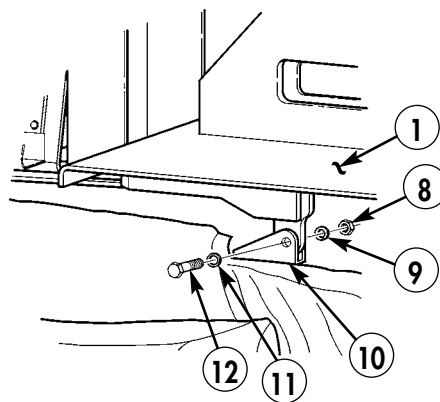

Figure 5-16.

**NOTE**

Do not install mounting hardware on top of integrated rack at this time. Not installing this hardware leaves the integrated rack free to pivot to assist in routing of cabling. Secure rack only after all cabling has been routed.

- 8-8. Mount integrated rack (1) to existing radio rack mount (10) using capscrew (12), washer (11), lockwasher (9), and nut (8). Repeat for opposite side. Do not tighten screws.



- 8. NUT – MS35649-2382 – QTY. 2
- 9. LOCKWASHER – MS35338-46 – QTY. 2
- 11. WASHER – 2436163 – QTY. 2
- 12. CAPSCREW – B1821BH038C225N – QTY. 2

Figure 5-17.

**Section IX. INSTALLATION OF SINGARS MOUNTING TRAY AND AMP GUARD**

- 9-1. Remove paint from vicinity of four mounting holes (6) on integrated rack (7) and vicinity of four mounting holes (5) on bottom of mounting base (4).
- 9-2. Apply anti-seize compound to vicinity of four mounting holes (6) on integrated rack and four mounting holes (5) on bottom of mounting base (4) as required.

**NOTE**

Two lockwashers and one nut are used on driver-side screws only.

- 9-3. Install mounting base (4) and amp guard (9) on integrated rack (7) with two capscrews (2), four lockwashers (1), and two nuts (8). Secure MT-6352/VRC mounting base (4) on integrated rack (7) with two capscrews (3) and two lockwashers (1).
- 9-4. Place warning decal (10) on amp guard (9).

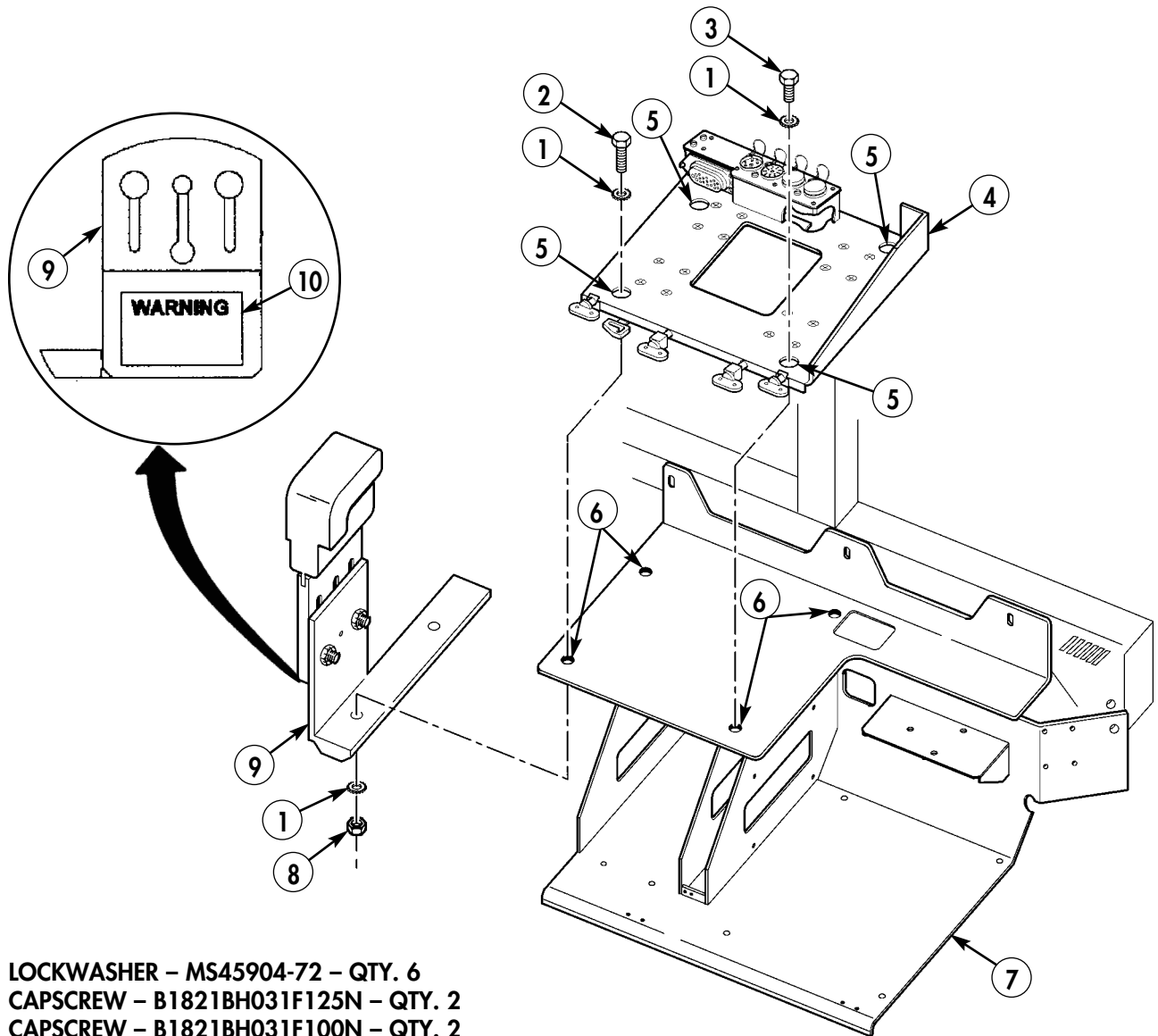

- 1. LOCKWASHER – MS45904-72 – QTY. 6
- 2. CAPSCREW – B1821BH031F125N – QTY. 2
- 3. CAPSCREW – B1821BH031F100N – QTY. 2
- 4. MOUNTING BASE, MT-6352/VRC – A3013367-1 – QTY. 1
- 8. NUT – MS51968-5 – QTY. 2
- 9. AMP GUARD – 872842-1 – QTY. 1
- 10. DECAL – 861868-2 – QTY. 1

Figure 5-18.

### Section X. FRONT POWER AMPLIFIER INSTALLATION

- 10-1.** Remove paint from vicinity of four mounting areas (2) on MT-6353/VRC mounting base (1) and apply anti-seize compound as required.

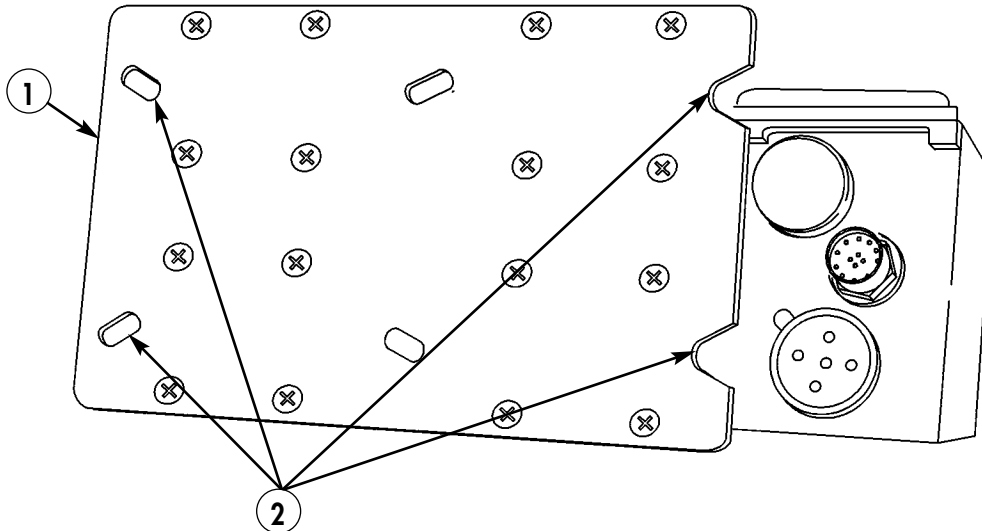

- 1. MOUNTING BASE, MT-6353/VRC – A3014053-1 – QTY. 1**

*Figure 5-19.*

- 10-2.** Remove paint from vicinity of four mounting holes (4) on integrated rack (3) and apply anti-seize compound as required.

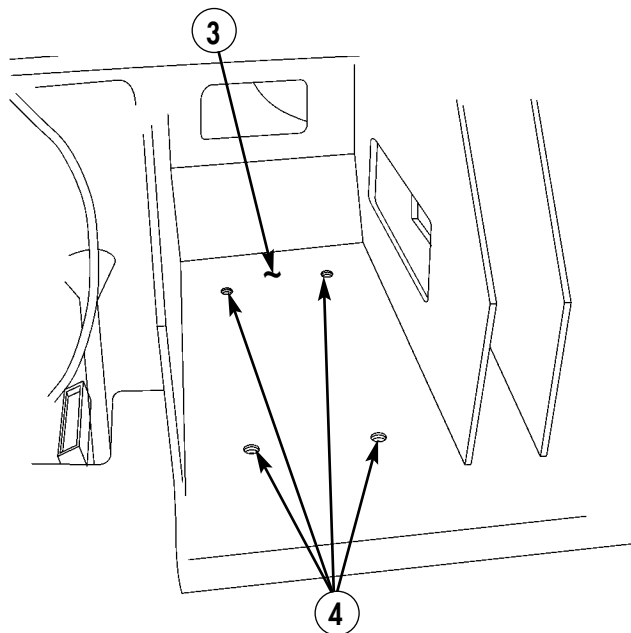

*Figure 5-20.*

- 10-3. Attach control cable (5) to MT-6353/VRC mounting base (1).
- 10-4. Attach power cable (6) to MT-6353/VRC mounting base (1).
- 10-5. Route cables (5) and (6) through hole in back of integrated rack (3).

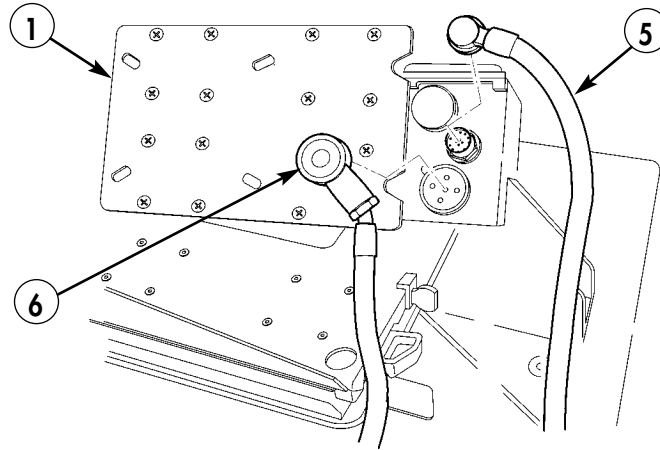

- 5. CONTROL CABLE – A3210672-1 – QTY. 1
- 6. POWER CABLE – A3154857-1 – QTY. 1

Figure 5-21.

**NOTE**

Ensure control cable and power cable are routed through hole in back of integrated rack before installing MT-6353/VRC mounting base.

- 10-6. Attach MT-6353/VRC mounting base (1) to integrated rack (3) with four capscrews (9) and (10), four lockwashers (8), and nut strip (7).

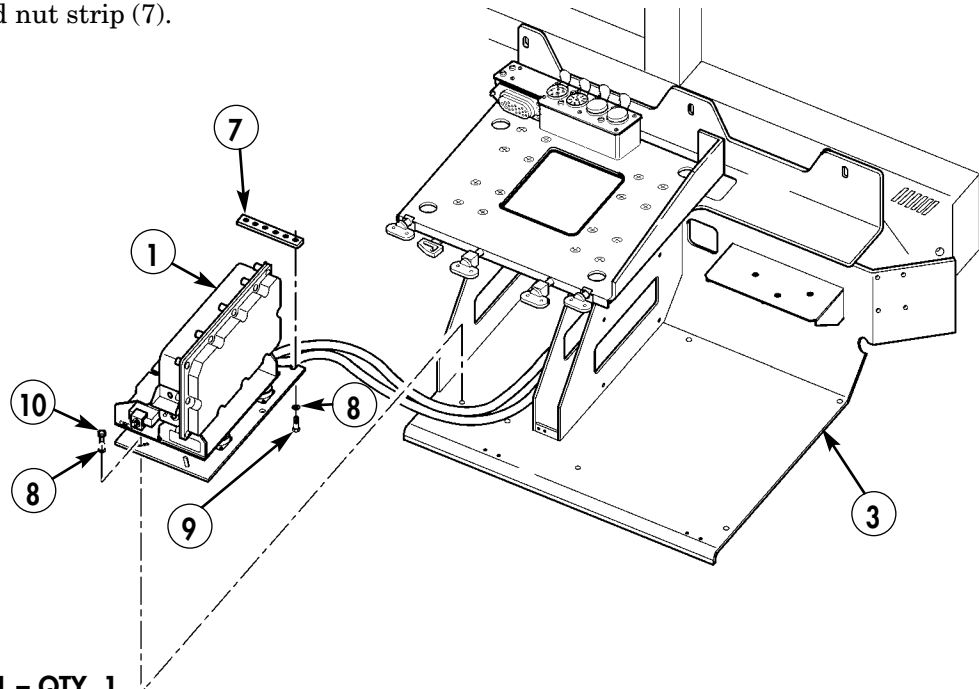

- 7. NUT STRIP – A3014064-1 – QTY. 1
- 8. LOCKWASHER – MS45904-72 – QTY. 4
- 9. CAPSCREW – B1821BH031F125N – QTY. 2
- 10. CAPSCREW – B1821BH031F075N – QTY. 2

Figure 5-22.

## Section XI. FCB2 COMPONENTS INSTALLATION

### NOTE

SINGARS model AN/VRC-92F shown.

- 11-1. Remove paint from vicinity of holes (8) on integrated rack (7) and on both sides from vicinity of corresponding holes (10) on CPU isolation kit (4). Apply anti-seize compound as required.
- 11-2. Install CPU isolation kit (4) on integrated rack (7) with three capscrews (3), washers (2), and lockwashers (1), leaving open holes (8) and (10).
- 11-3. Install keyboard (9) in keyboard slot of integrated rack (7).
- 11-4. Install CPU (6) on CPU isolation kit (4) with two existing fastener guards (5).
- 11-5. Fabricate ground strap (13) from 8.00-in. length of braided wire and two terminal lugs.
- 11-6. Install ground strap (13) on CPU ground stud (17) with existing washer (14), lockwasher (15), and wingnut (16).
- 11-7. Install ground strap (13) on CPU isolation kit (4) and integrated rack (7), with capscREW (11), washer (2), and two lockwashers (12).

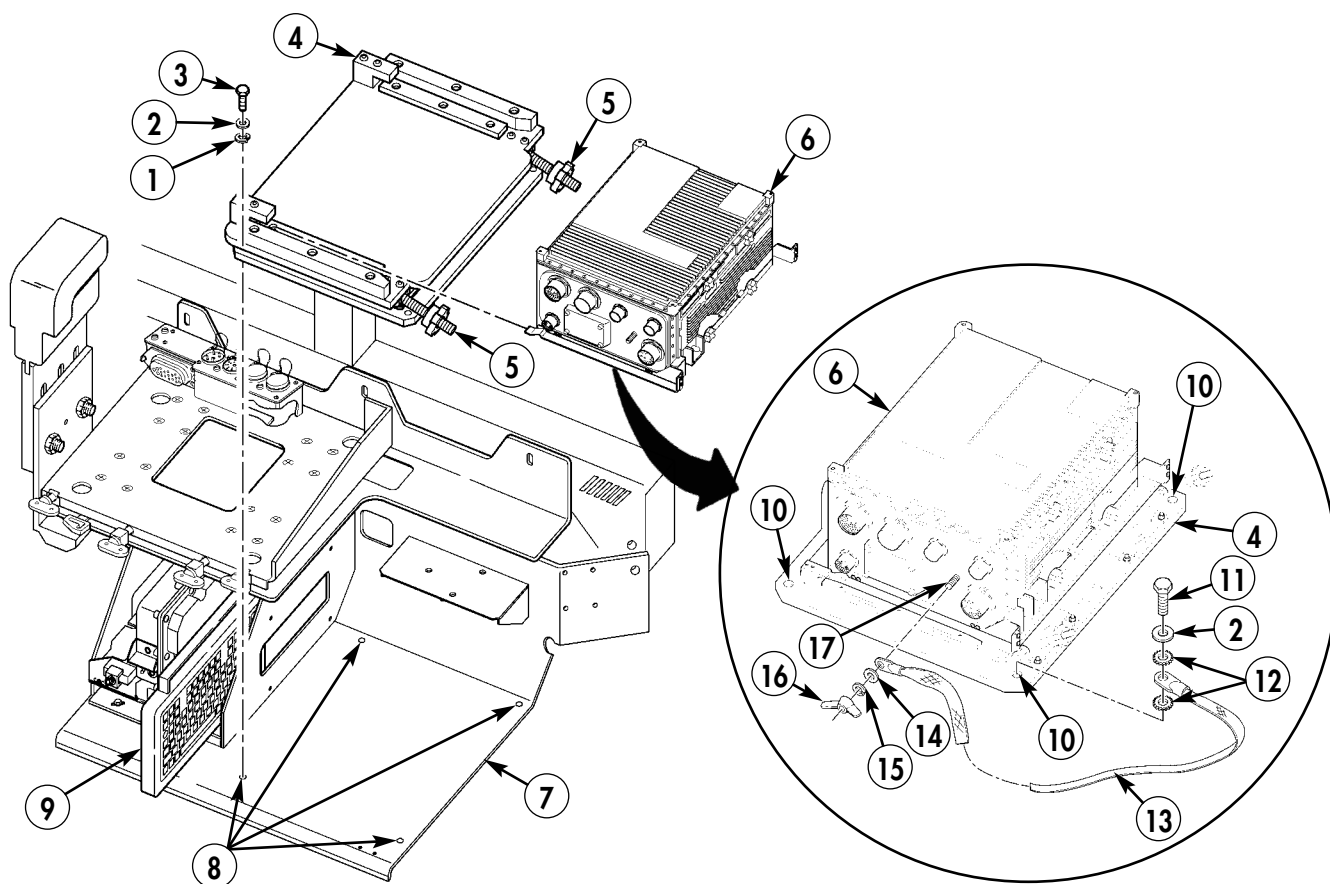

1. LOCKWASHER – MS35338-44 – QTY. 3
2. WASHER – 2436161 – QTY. 4
3. CAPSCREW – B1821BH025C100N – QTY. 3
4. CPU ISOLATION KIT – 872826-2 – QTY. 1
6. CPU – 881292-1 – QTY. 1
11. CAPSCREW – B1821BH025C125N – QTY. 1
12. LOCKWASHER – MS45904-68 – QTY. 2
13. CPU GROUND STRAP
  - BRAIDED WIRE – AA59569F30T0375 – QTY. A/R
  - TERMINAL LUG – MS20659-141 – QTY. 2

Figure 5-23.



- 11-8. Install ramball mount (26) on integrated rack (7) with two screws (25), screw (3), lockwasher (1), lanyard (18), washer (29), three lockwashers (1), and nuts (28).
- 11-9. Install display isolation kit (22) on display lock assembly (21) with four bolts (30), spacers (19), lanyard (18), and four wingnuts (20).
- 11-10. Install display unit (24) on display isolation kit (22) with four screws (23).
- 11-11. Install display lock assembly (21) on ramball mount (26).
- 11-12. Fabricate display ground strap (27) from 8-in. length of braided wire and two terminal lugs.

**NOTE**

Remove paint from vicinity of integrated rack mounting hole before performing step 11-13. Apply anti-seize compound as required. Ground strap will be installed on integrated rack only when integrated rack is fully secured in vehicle.

- 11-13. Install display ground strap (27) on display ground stud (33) with existing lockwasher (32) and wingnut (31).

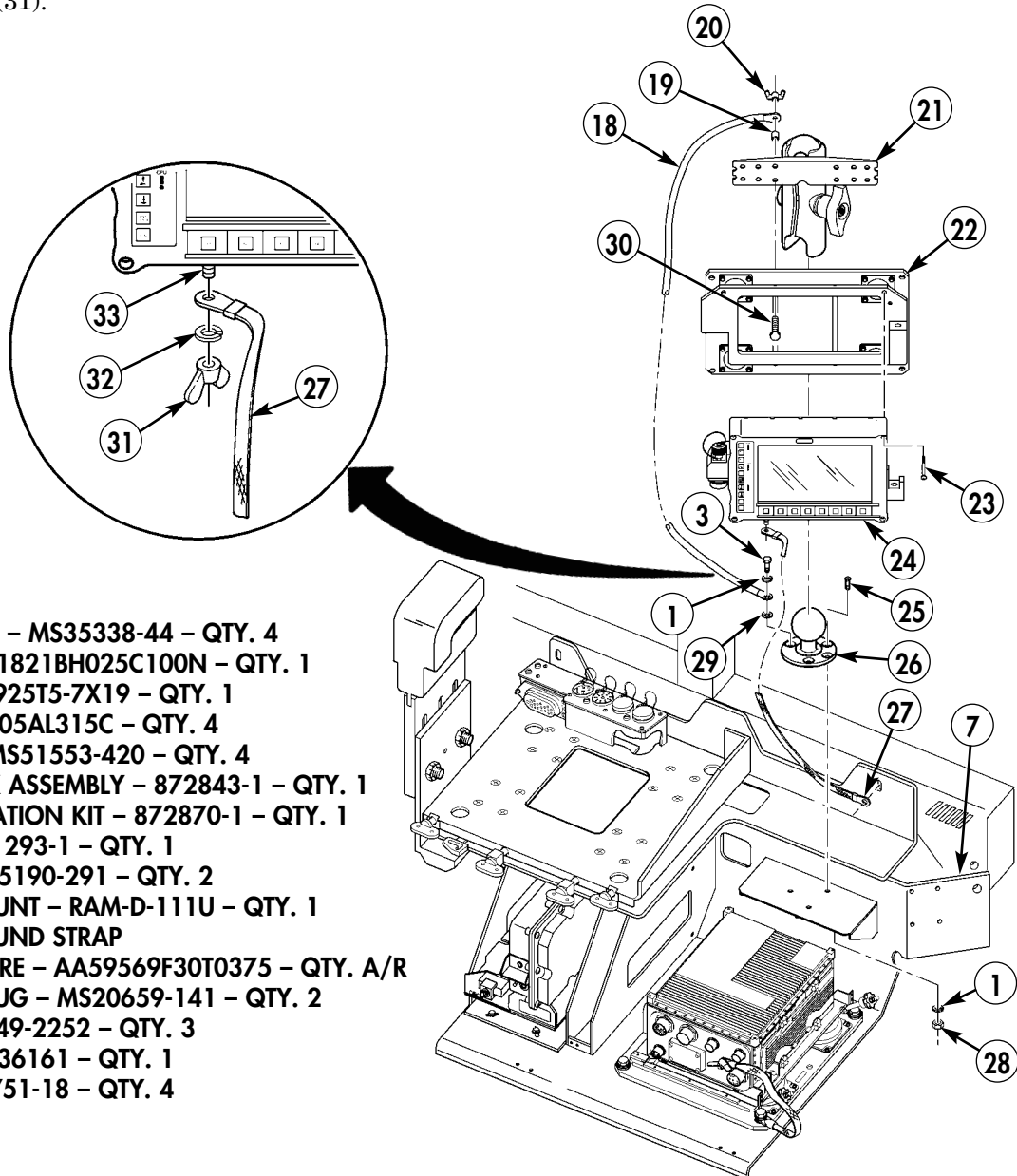

- 1. LOCKWASHER – MS35338-44 – QTY. 4
- 3. CAPSCREW B1821BH025C100N – QTY. 1
- 18. LANYARD – 8925T5-7X19 – QTY. 1
- 19. SPACER – 10705AL315C – QTY. 4
- 20. WINGNUT – MS51553-420 – QTY. 4
- 21. DISPLAY LOCK ASSEMBLY – 872843-1 – QTY. 1
- 22. DISPLAY ISOLATION KIT – 872870-1 – QTY. 1
- 24. DISPLAY – 881293-1 – QTY. 1
- 25. SCREW – MS35190-291 – QTY. 2
- 26. RAMBALL MOUNT – RAM-D-111U – QTY. 1
- 27. DISPLAY GROUND STRAP
  - BRAIDED WIRE – AA59569F30T0375 – QTY. A/R
  - TERMINAL LUG – MS20659-141 – QTY. 2
- 28. NUT – MS35649-2252 – QTY. 3
- 29. WASHER – 2436161 – QTY. 1
- 30. BOLT – MS35751-18 – QTY. 4

Figure 5-24.

## Section XII. SERIAL INTERFACE ADAPTER DEVICE (SIAD) CABLES INSTALLATION

- 12-1. Install W3 cable (4) to SIAD (1).
- 12-2. Install W3N cable (2) to SIAD (1).
- 12-3. Install W3P cable (3) to SIAD (1).

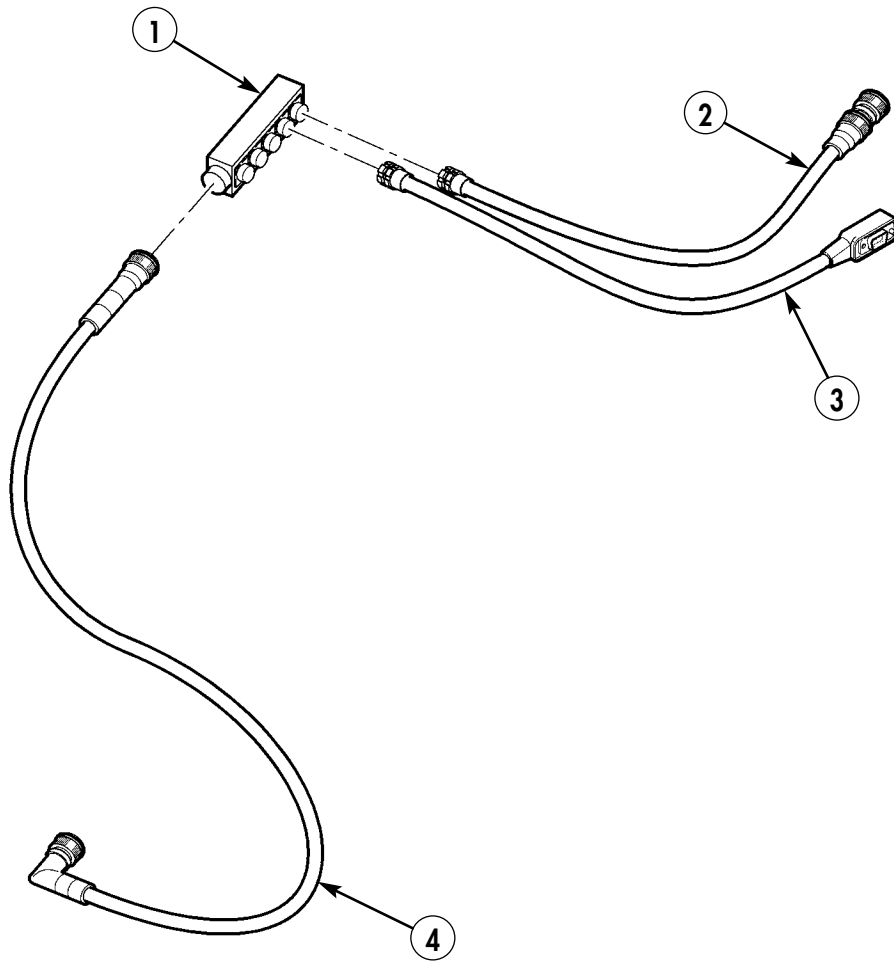

- 1. SERIAL INTERFACE ADAPTER DEVICE – 881331-1 – QTY. 1
- 2. W3N CABLE – 881336-1 – QTY. 1
- 3. W3P CABLE – 881335-1 – QTY. 1
- 4. W3 CABLE – P/O 881331-1 – QTY. 1

Figure 5-25.

### Section XIII. SERIAL INTERFACE ADAPTER DEVICE (SIAD) INSTALLATION

Position SIAD (1) securely between FBCB2 (2) and keyboard tray (3) on integrated rack (4).

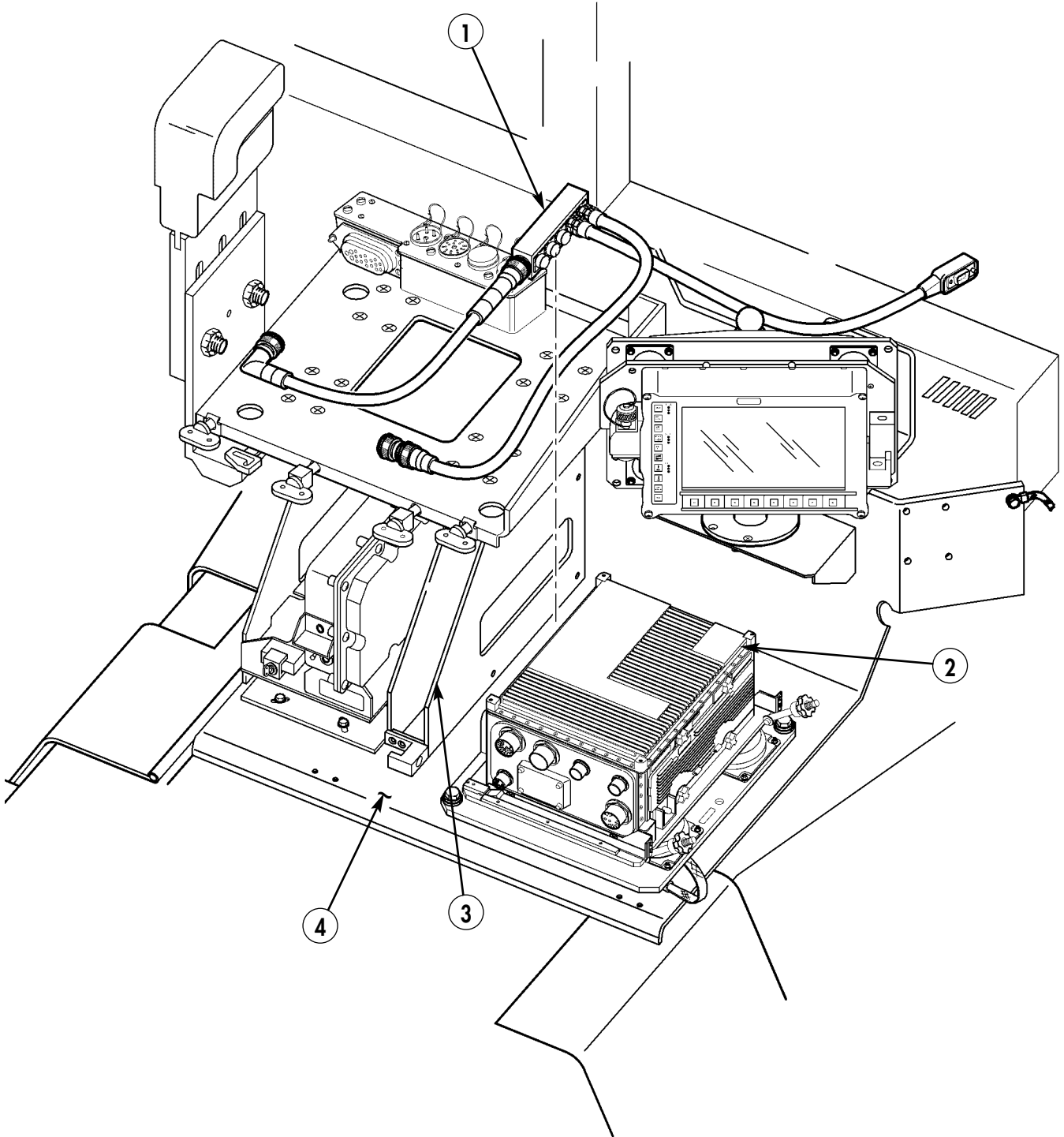
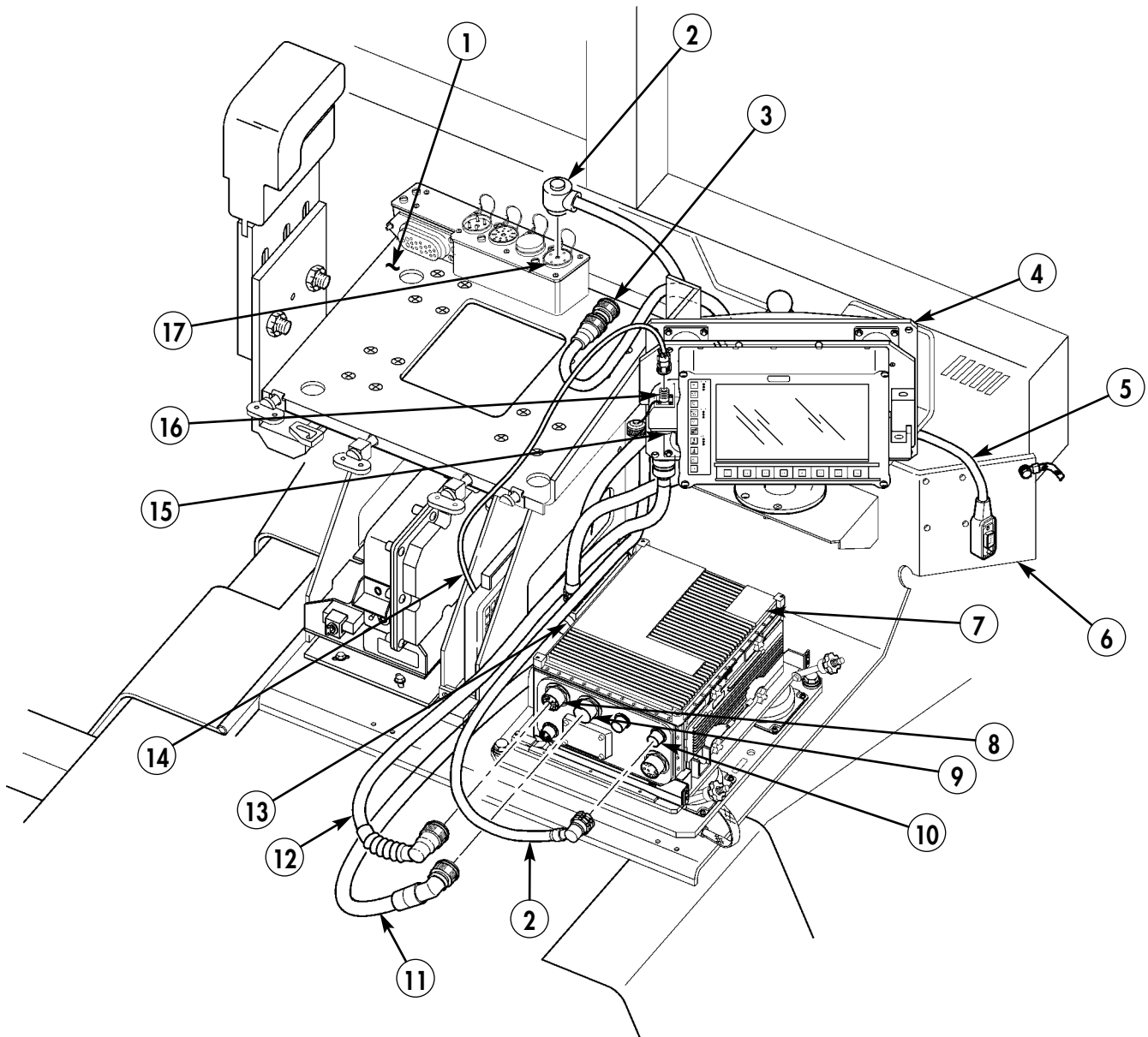

Figure 5-26.

### Section XIV. FBCB2 CABLES INSTALLATION

- 14-1. Connect W3 cable (11) from SIAD (13) to J3 connector (9) on FBCB2 processor (7).
- 14-2. Route W3P cable (5) from SIAD (13) to DAGR mount (6).
- 14-3. Connect W2 cable (12) to J4 connector (8) on FBCB2 processor (7) and J1 connector (15) on FBCB2 display unit (4).
- 14-4. Connect W1 cable (2) to J1 connector (10) on FBCB2 processor (7). Route W1 cable (2) to A4J2 connector (17).
- 14-5. Connect keyboard cable (14) to J2 connector (16) on FBCB2 display unit (4).
- 14-6. Route W1J1 cable (3) to SINCGARS mount (1).



- 2. W1 CABLE - 866003-3 - QTY. 1
- 12. W2 CABLE - 881327-1 - QTY. 1

Figure 5-27.

14-7. Install Vehicular Amplifier Adapter (VAA) (18) into SINCGARS mount (1).

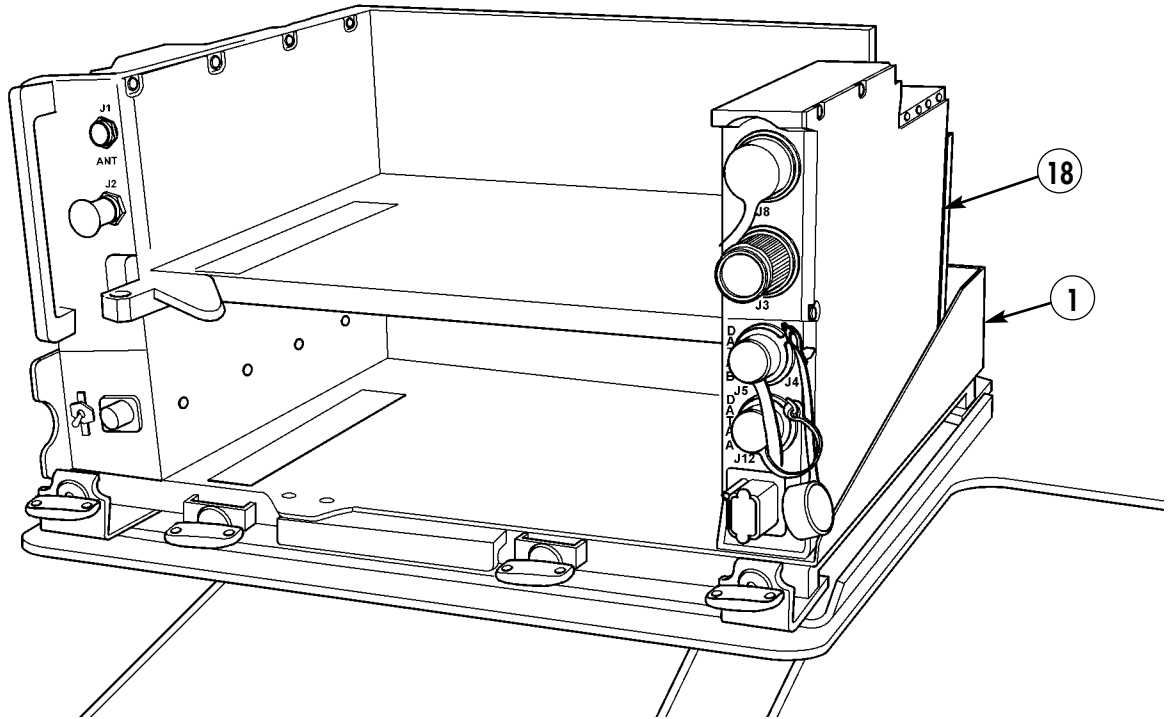

Figure 5-28.

14-8. Connect W3N cable (19) to J3 (20) connector on VAA (18).

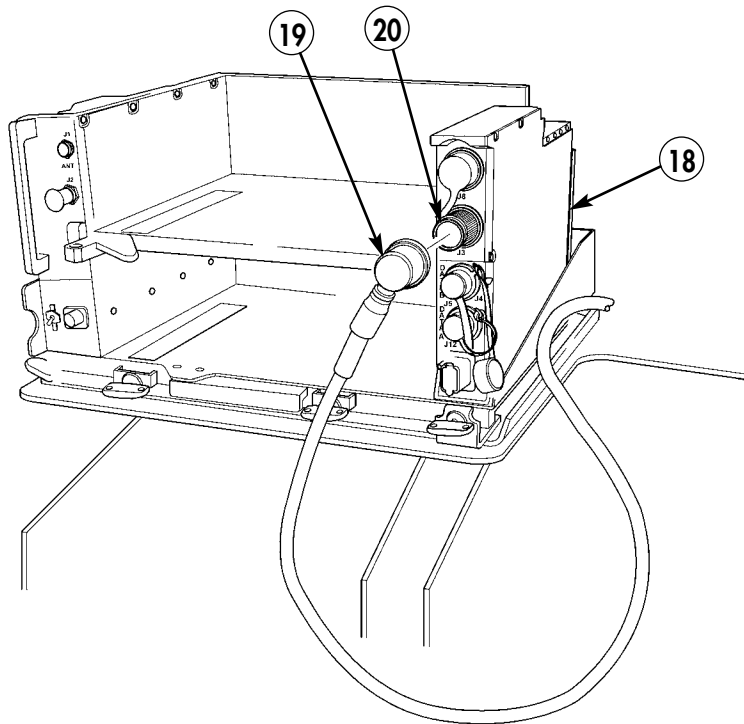

Figure 5-29.

### Section XV. LOUDSPEAKER AND MULTI-NET RACK INSTALLATION

**NOTE**

Remove paint from vicinity of all mounting holes.

- 15-1.** Using four speaker mounting plates (3) as templates, locate, mark, and drill sixteen 0.281-in. diameter holes in lower shelf (4).

**NOTE**

- To ensure proper fit, keep mounting holes near outside edge of speaker mounting plate holes.
- Do not install screws in two far-left side mounting holes at this time. These holes align with the frame and require longer screws. These screws are installed in step 15-3.

- 15-2.** Install four speaker mounting plates (3) on lower shelf (4) with fourteen capscrews (1), twenty-eight washers (2), fourteen lockwashers (5), and nuts (6).

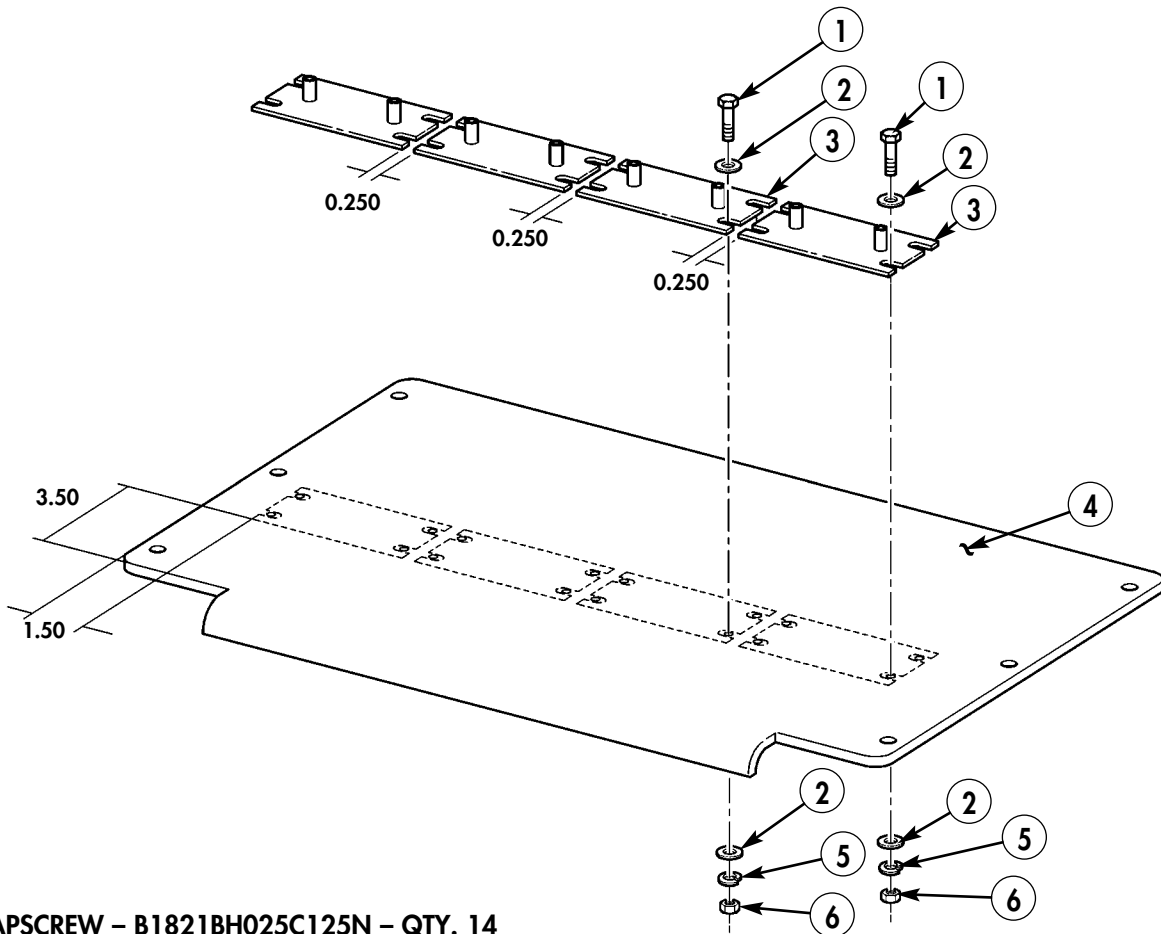

- 1. CAPSCREW – B1821BH025C125N – QTY. 14
- 2. WASHER – 2436161 – QTY. 28
- 3. MOUNTING PLATE – A3014550-1 – QTY. 4
- 5. LOCKWASHER – MS35338-44 – QTY. 14
- 6. NUT – 9419143 – QTY. 14

Figure 5-30.

**NOTE**

- Use existing holes of D-rings to mount frame and shelf. Older model trucks have existing strux nuts. If installing multi-net rack on a newer model vehicle, use locknuts.
- Any missing strux nuts must be replaced by locknuts.

- 15-3.** Install lower shelf (4) on frame (9) with two screws (22), four washers (19), two lockwashers (18), and nuts (17).
- 15-4.** Install lower shelf (4) and frame (9) on cargo bed (15) with two capscrews (21), lockwashers (20), spacers (16), and locknuts (14) if necessary.
- 15-5.** Secure lower shelf (4) on frame (9) and cargo bed (15) with two capscrews (7), lockwashers (8), and locknuts (14) if necessary.
- 15-6.** Secure frame (9) on cargo bed (15) with three capscrews (10), lockwashers (11), washers (12), spacers (13), and locknuts (14) if necessary.

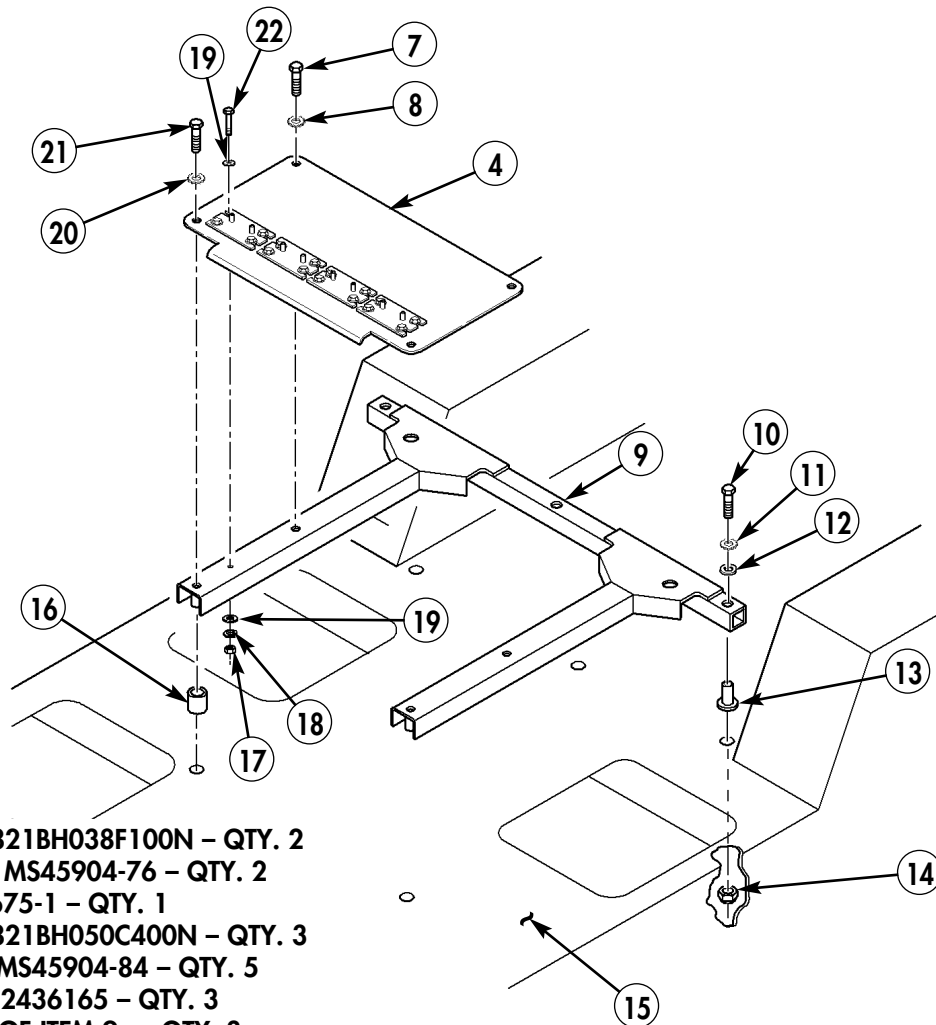

7. CAPSCREW – B1821BH038F100N – QTY. 2  
 8. LOCKWASHER – MS45904-76 – QTY. 2  
 9. FRAME – A3210675-1 – QTY. 1  
 10. CAPSCREW – B1821BH050C400N – QTY. 3  
 11. LOCKWASHER – MS45904-84 – QTY. 5  
 12. WASHER, FLAT – 2436165 – QTY. 3  
 13. SPACER – PART OF ITEM 9 – QTY. 3  
 16. SPACER – PART OF ITEM 9 – QTY. 2  
 17. NUT – 9419143 – QTY. 2  
 18. LOCKWASHER – MS35338-44 – QTY. 2  
 19. WASHER – 2436161 – QTY. 4  
 20. WASHER, FLAT – 2436165 – QTY. 2  
 21. CAPSCREW – B1821BH050C450N – QTY. 2  
 22. SCREW – B1821BH025C150N – QTY. 2

Figure 5-31.

- 15-7. Attach braces (26) to top shelf (25) with two screws (23), lockwashers (24), and nuts (30).
- 15-8. Attach side racks (29) to bottom shelf (25) with eight screws (23), lockwashers (24), and nuts (30).
- 15-9. Position top shelf (25) on side racks (29) and secure with eight screws (23), lockwashers (24), and nuts (30).
- 15-10. Secure braces (26) to bottom shelf (25) with two screws (27), four washers (28), and two nuts (31).

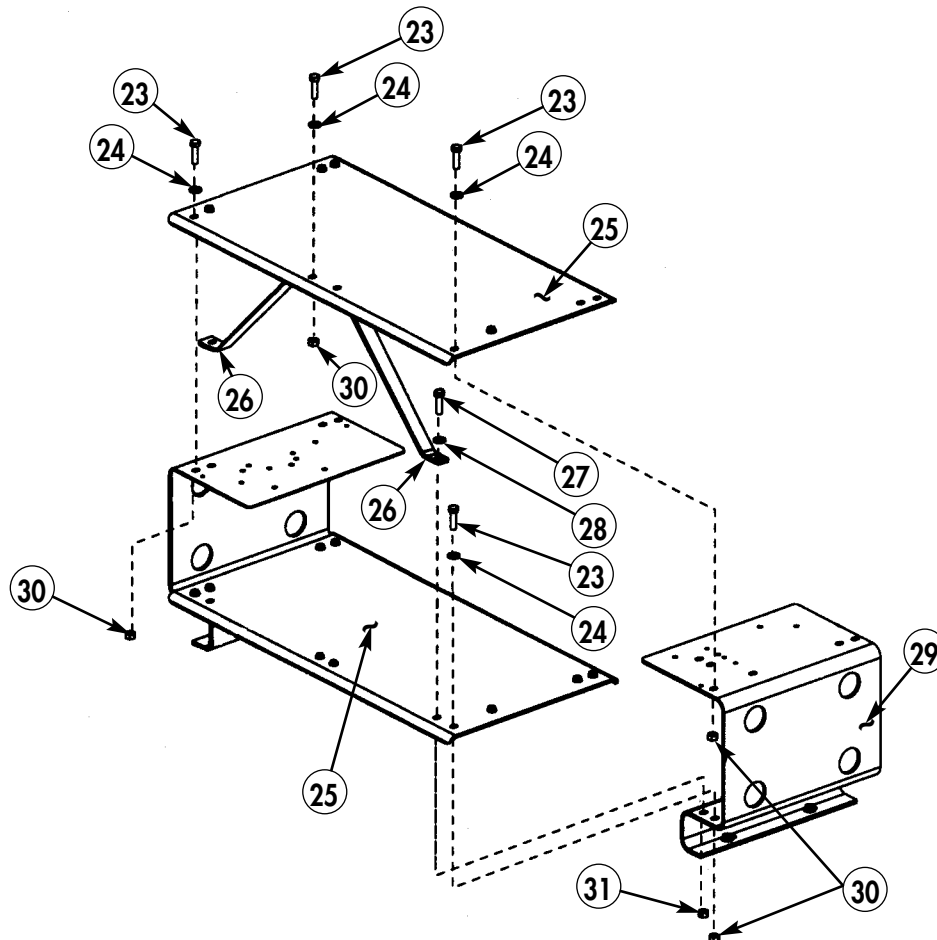

- 23. SCREW - MS90726-36 - QTY. 18
- 24. LOCKWASHER - MS45904-72 - QTY. 36
- 25. SHELF, ELECTRICAL - A3046236 - QTY. 2
- 26. BRACE - A3046237 - QTY. 1
- 27. SCREW - MS90725-8 - QTY. 2
- 28. WASHER - 2436161 - QTY. 4
- 29. BRACKET, RADIO RACK - A3046235 - QTY. 2
- 30. NUT - MS51967-5 - QTY. 18
- 31. NUT - MS51967-2 - QTY. 2

Figure 5-32.



**NOTE**

Remove paint from vicinity of all mounting holes. Apply anti-seize compound as required.

- 15-11. Install assembled multi-net rack (32) on frame (9) with four capscrews (34) and lockwashers (35).
- 15-12. Install grommet material (33) in eight holes of multi-net rack (32).
- 15-13. Install grommet material (36) in two holes of frame (9).

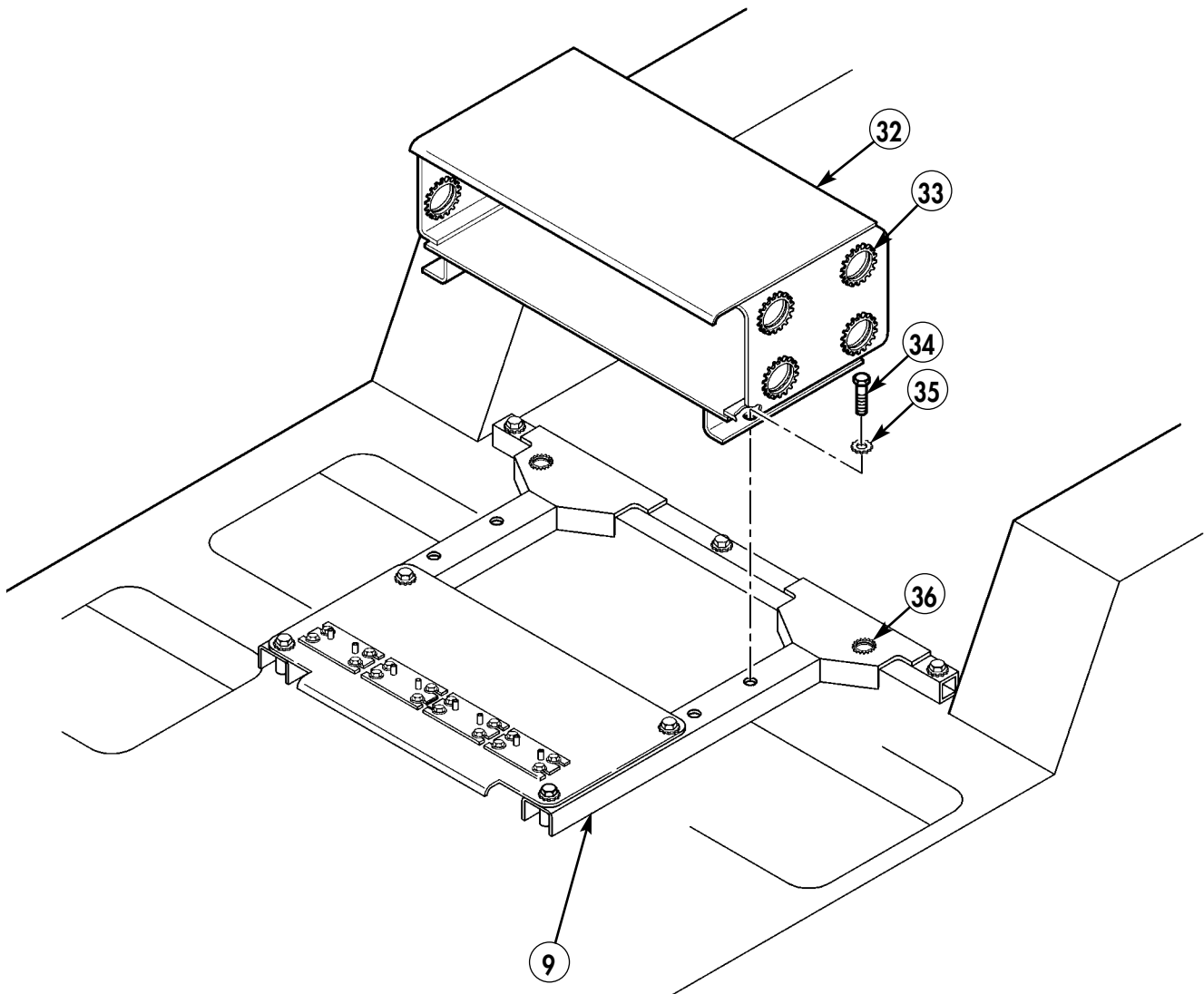

- 33. GROMMET MATERIAL – MS21266-6N – QTY. A/R
- 34. CAPSCREW – B1821BH038F100N – QTY. 4
- 35. LOCKWASHER – MS45904-76 – QTY. 4
- 36. GROMMET MATERIAL – MS21266-4N – QTY. A/R

*Figure 5-34.*

**15-14.** Install four loudspeakers (37) on speaker mounting plate (3) with eight existing externally relieved body screws (38).

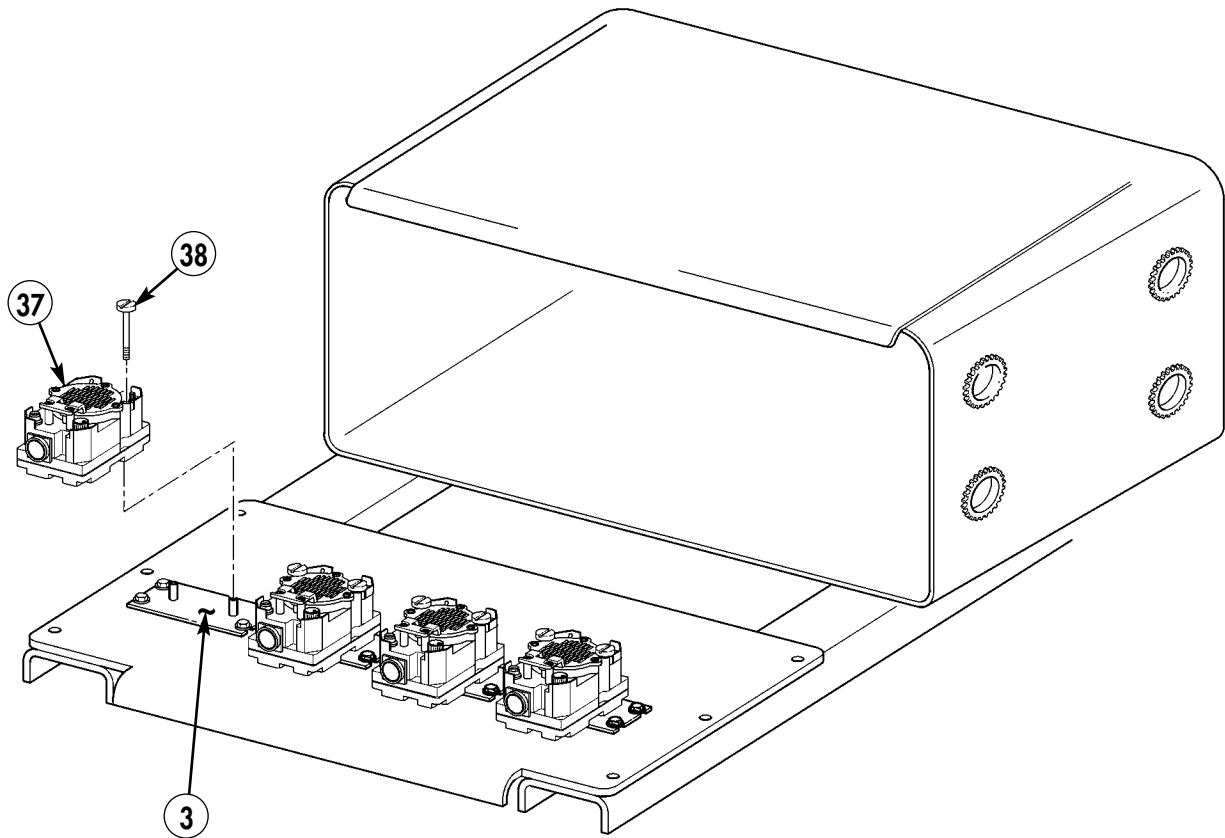

- 37. LOUDSPEAKER – A3014065-1 – QTY. 4**
- 38. EXTERNALLY-RELIEVED BODY SCREW – P/O A3014065-1 – QTY. 8**

*Figure 5-34.*

## Section XVI. CHARGE CONTROL BOX INSTALLATION

- 16-1.** Locate, mark, and drill one 0.391-in. diameter hole (6) in multi-net rack (7).
- 16-2.** Using charge control box (4) as template, locate, mark, and drill three 0.391-in. diameter holes (8) in multi-net rack (7).
- 16-3.** Install four inserts (5) in multi-net rack (7).
- 16-4.** Install charge control box (4) on multi-net rack (7) with four screws (1), washers (2), and lockwashers (3).

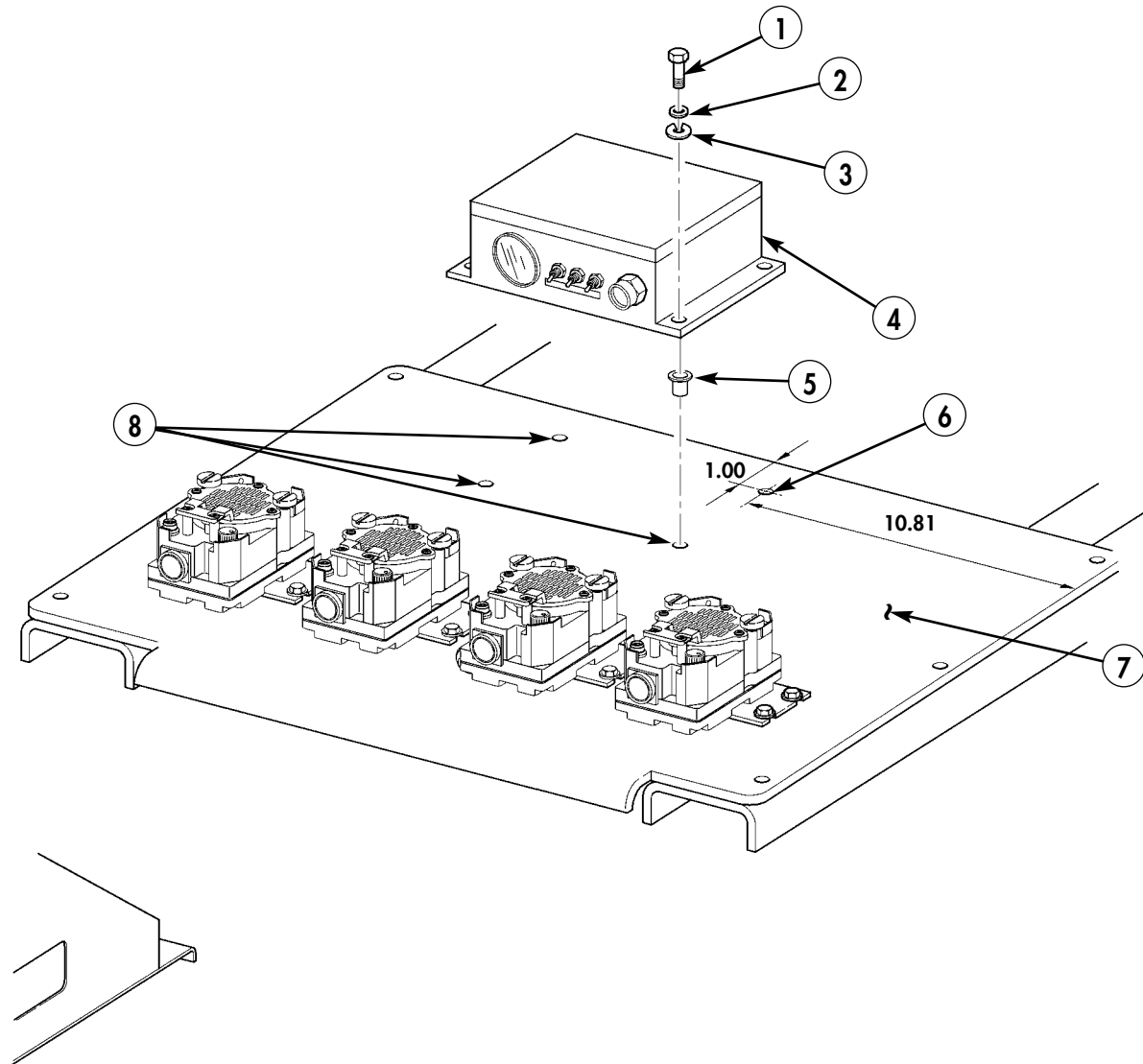

- 1. SCREW – B1821BH025C100N – QTY. 4**  
**2. WASHER – 2436161 – QTY. 4**  
**3. LOCKWASHER – 120380 – QTY. 4**  
**4. CHARGE CONTROL BOX – PKMM-000-002 – QTY. 1**  
**5. INSERT – 12446871-2 – QTY. 4**

*Figure 5-35.*

### Section XVII. LOWER REAR SINGARS MOUNT INSTALLATION

17-1. Locate, mark, and drill one 0.343-in. diameter hole (2) in lower shelf of multi-net rack (1).

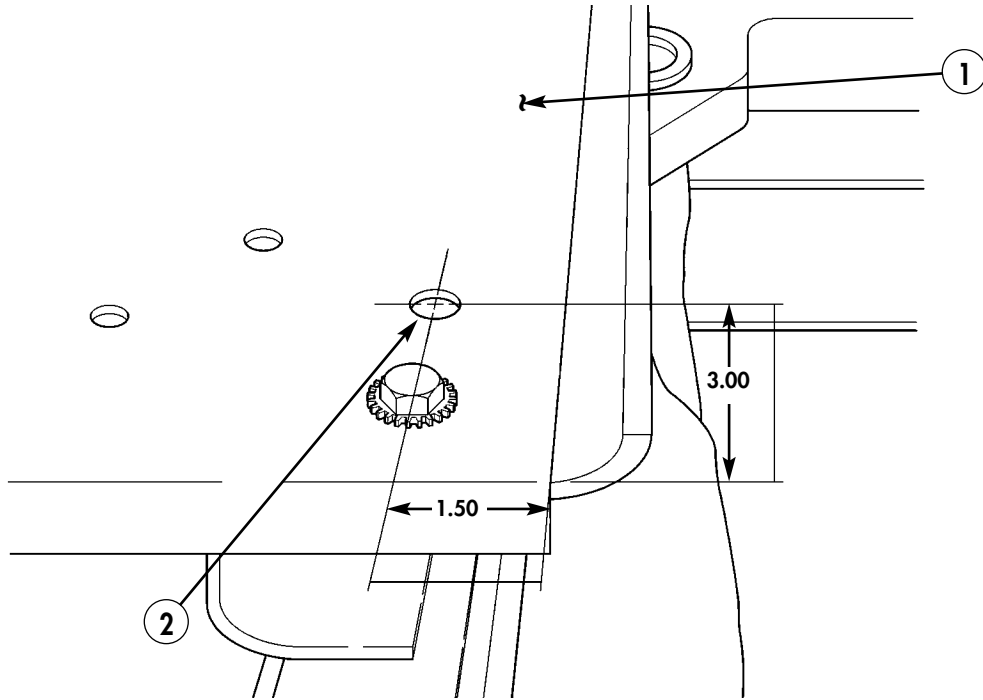

Figure 5-36.

17-2. Using SINGARS mounting base MT-6352/VRC as template, locate, mark, and drill four 0.343-in. diameter holes (3) in lower shelf of multi-net rack (1).

17-3. Remove paint from vicinity of holes (3) and apply anti-seize compound as required.

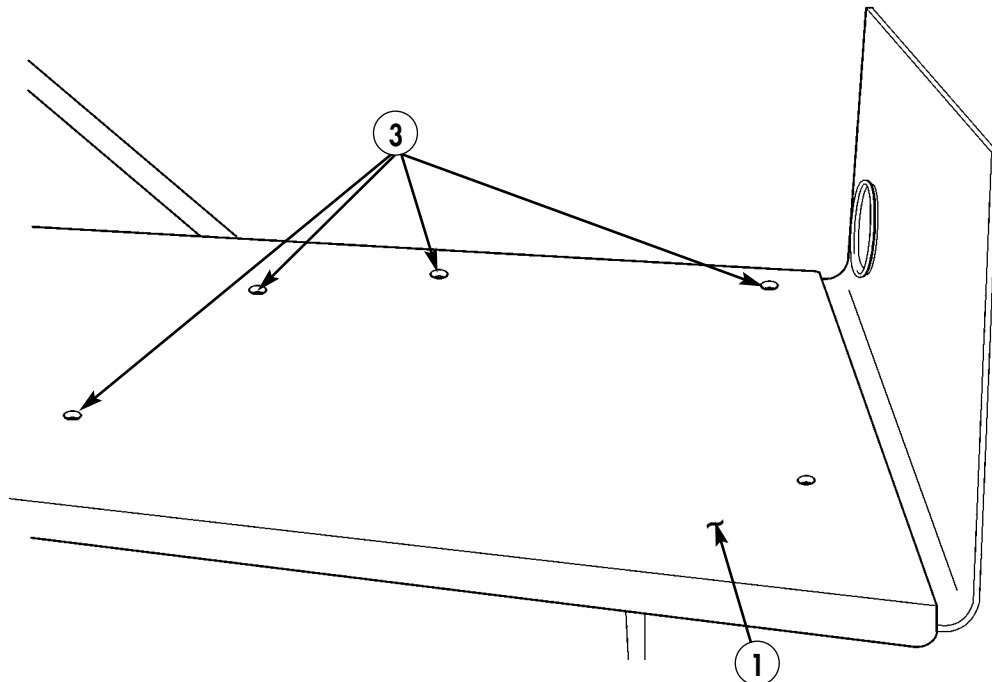
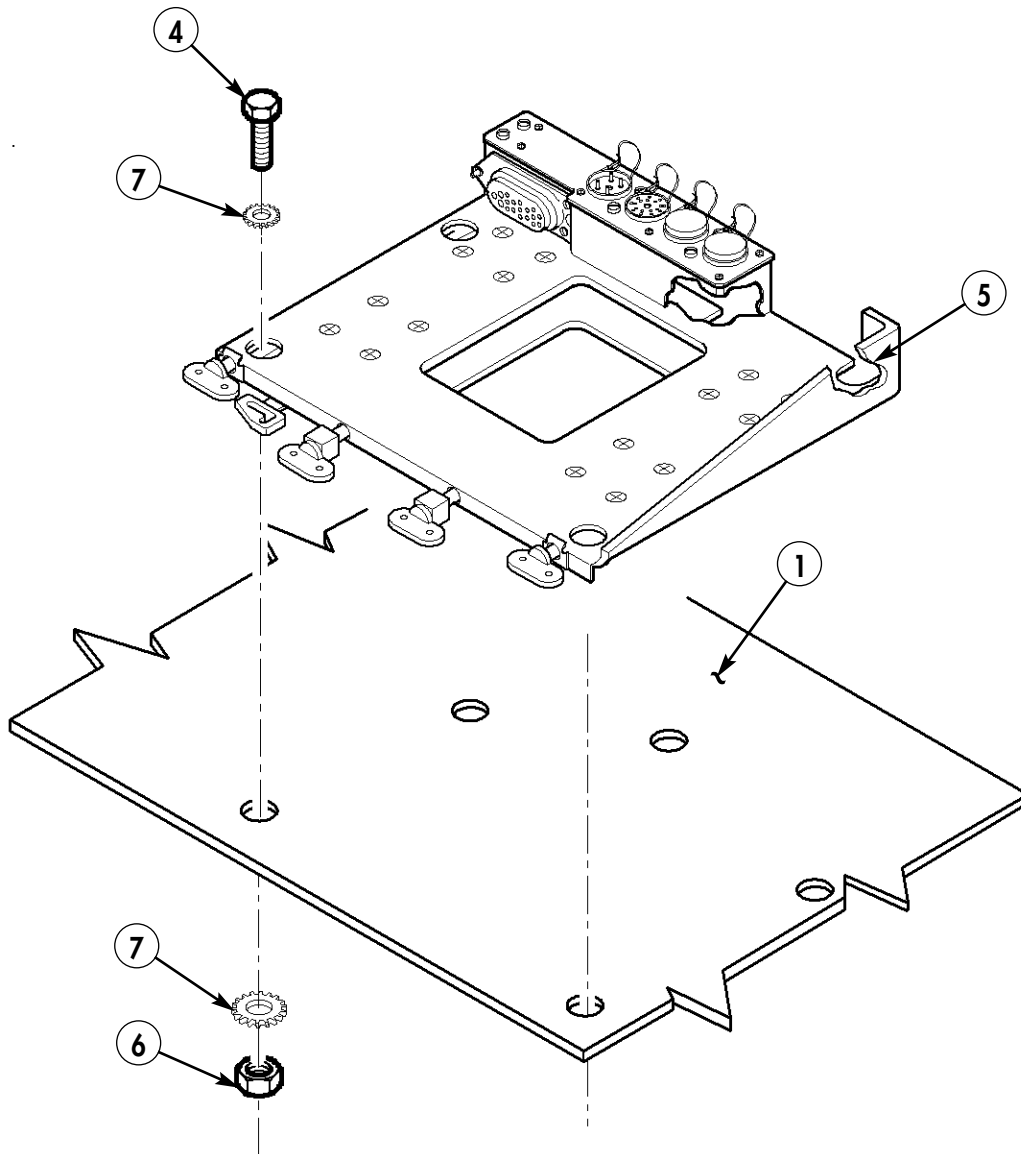

Figure 5-37.

- 17-4.** Install SINGARS mounting base MT-6352/VRC (5) on multi-net rack (1) using four capscrews (4), eight lockwashers (7), and four nuts (6).



4. CAPSCREW – B1821BH031F100N – QTY. 4  
 5. MOUNTING BASE, MT-6352/VRC – A3013367-1 – QTY. 1  
 6. NUT – MS51968-5 – QTY. 4  
 7. LOCKWASHER – MS45904-72 – QTY. 8

*Figure 5-38.*

**Section XVIII. LOWER REAR POWER AMPLIFIER INSTALLATION**

**18-1.** Position power amp mounting base MT6353/VRC (2) on multi-net rack (1).

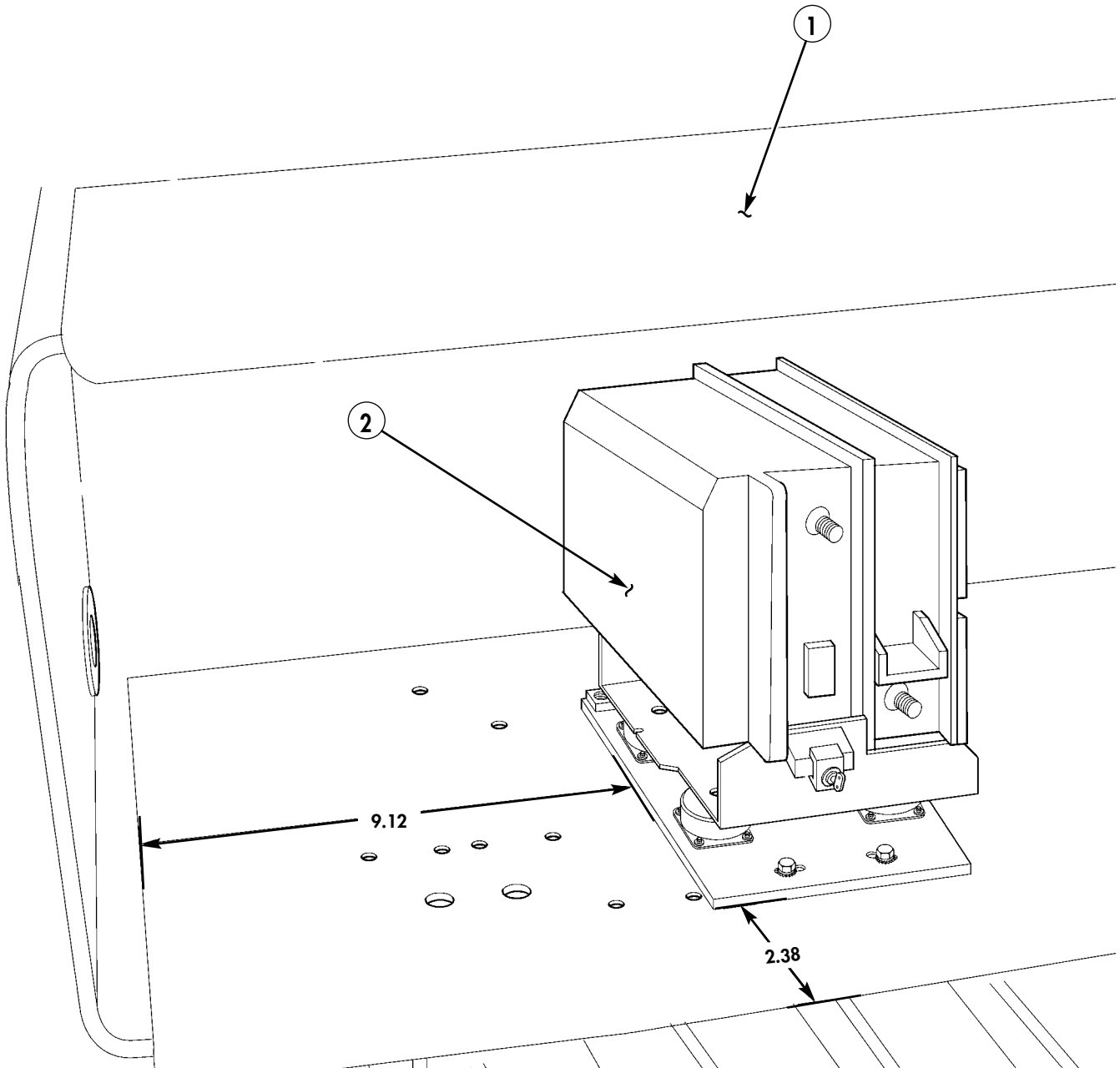

**2. POWER AMP MOUNTING BASE, MT6353/VRC – A3014053-1 – QTY. 1**

*Figure 5-39.*

**18-2.** Using power amp mounting base MT6353/VRC as template, locate, mark, and drill four 0.343-in. diameter holes (3) in multi-net rack (1). Remove paint and apply anti-seize compound as required.

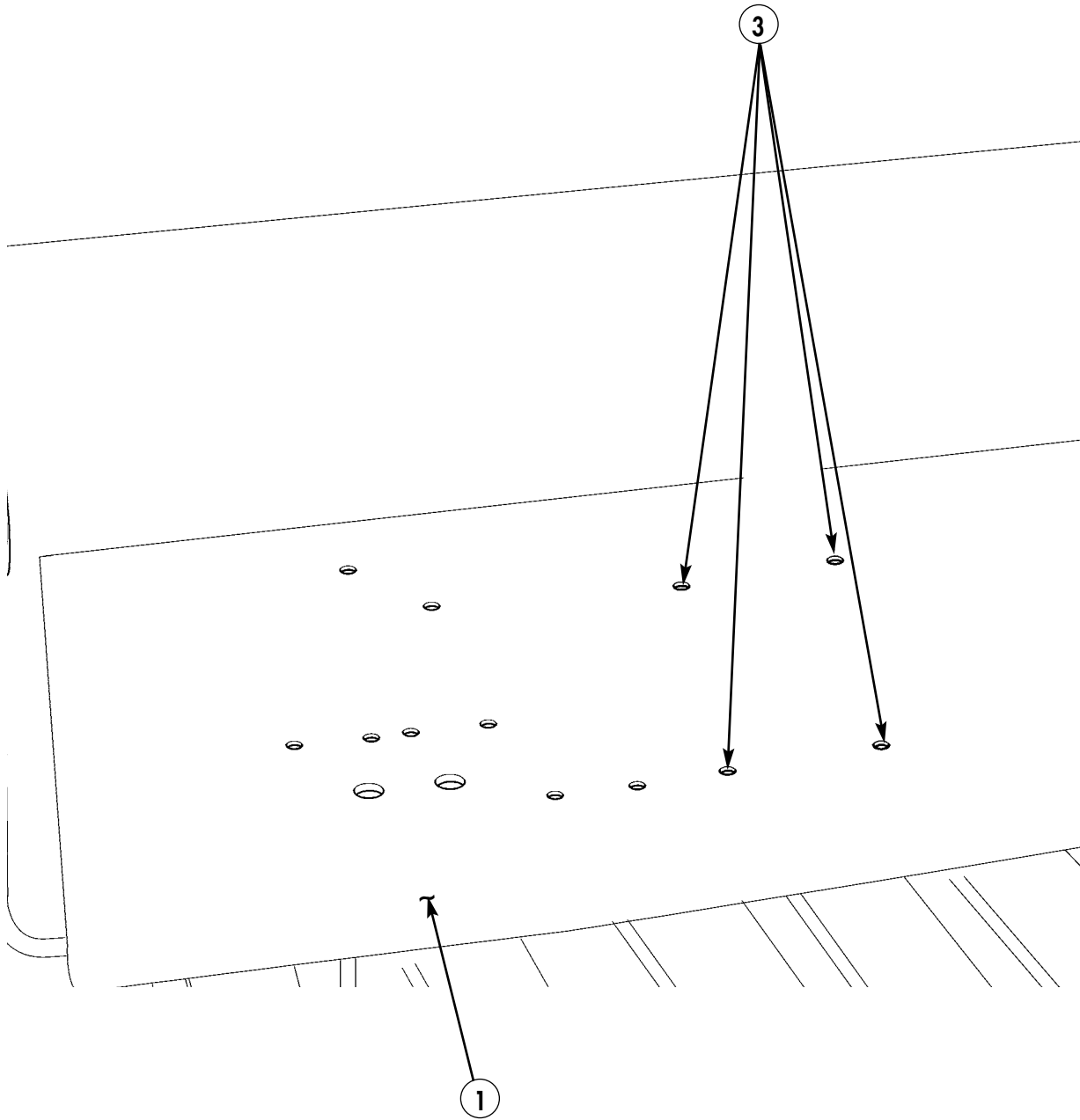

*Figure 5-40.*

18-3. Install power amp mounting base MT6353/VRC (2) on multi-net rack (1) with nut strip (8), four capscrews (4) and (7), six lockwashers (5), and two nuts (6).

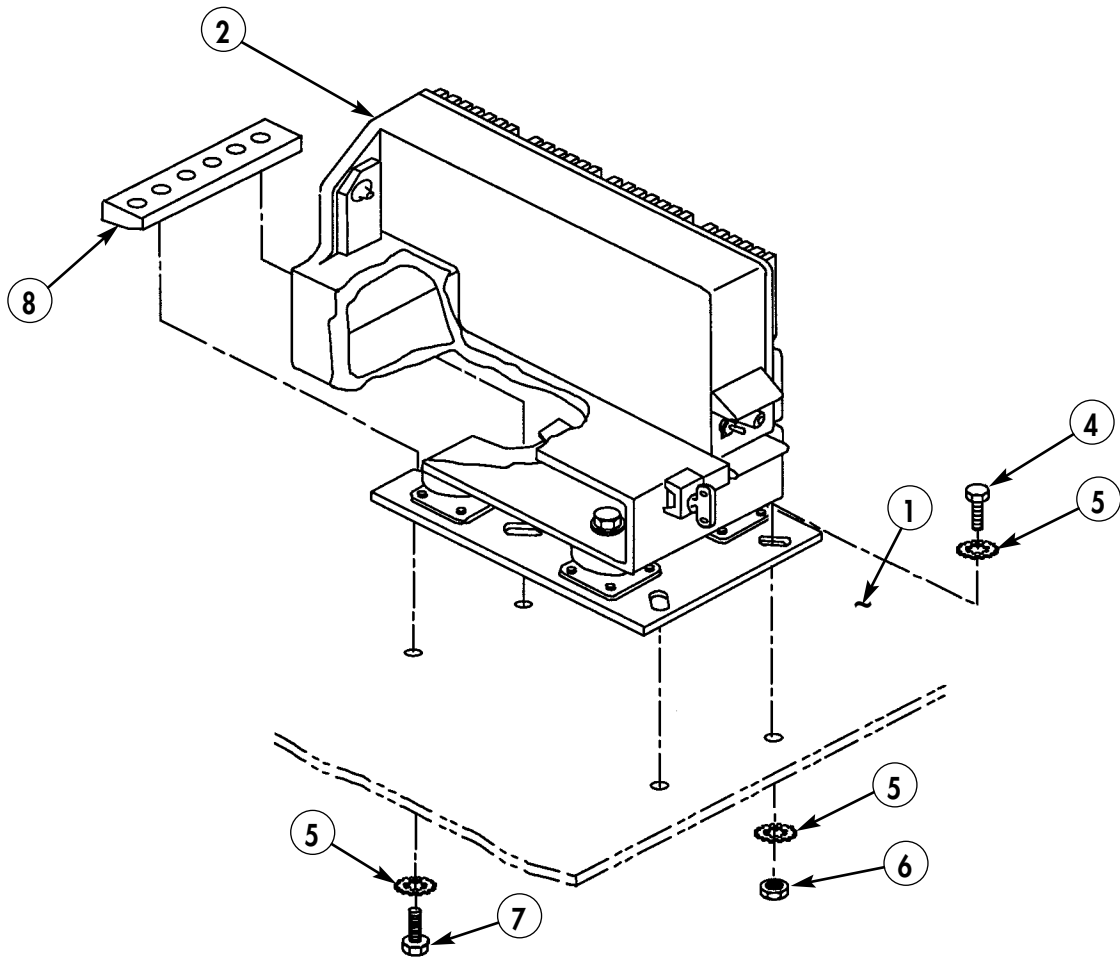

- 4. CAPSCREW – B1821BH031F075N – QTY. 2
- 5. LOCKWASHER – MS45904-72 – QTY. 6
- 6. NUT – 9418892 – QTY. 2
- 7. CAPSCREW – B1821BH031F125N – QTY. 2
- 8. NUT STRIP – A3014064-1 – QTY. 1

Figure 5-41.



- 18-4. Route power cable (8) from mounting base MT6353/VRC (2) around multi-net rack (1).
- 18-5. Route control cable (9) from mounting base MT6353/VRC (2) around multi-net rack (1).

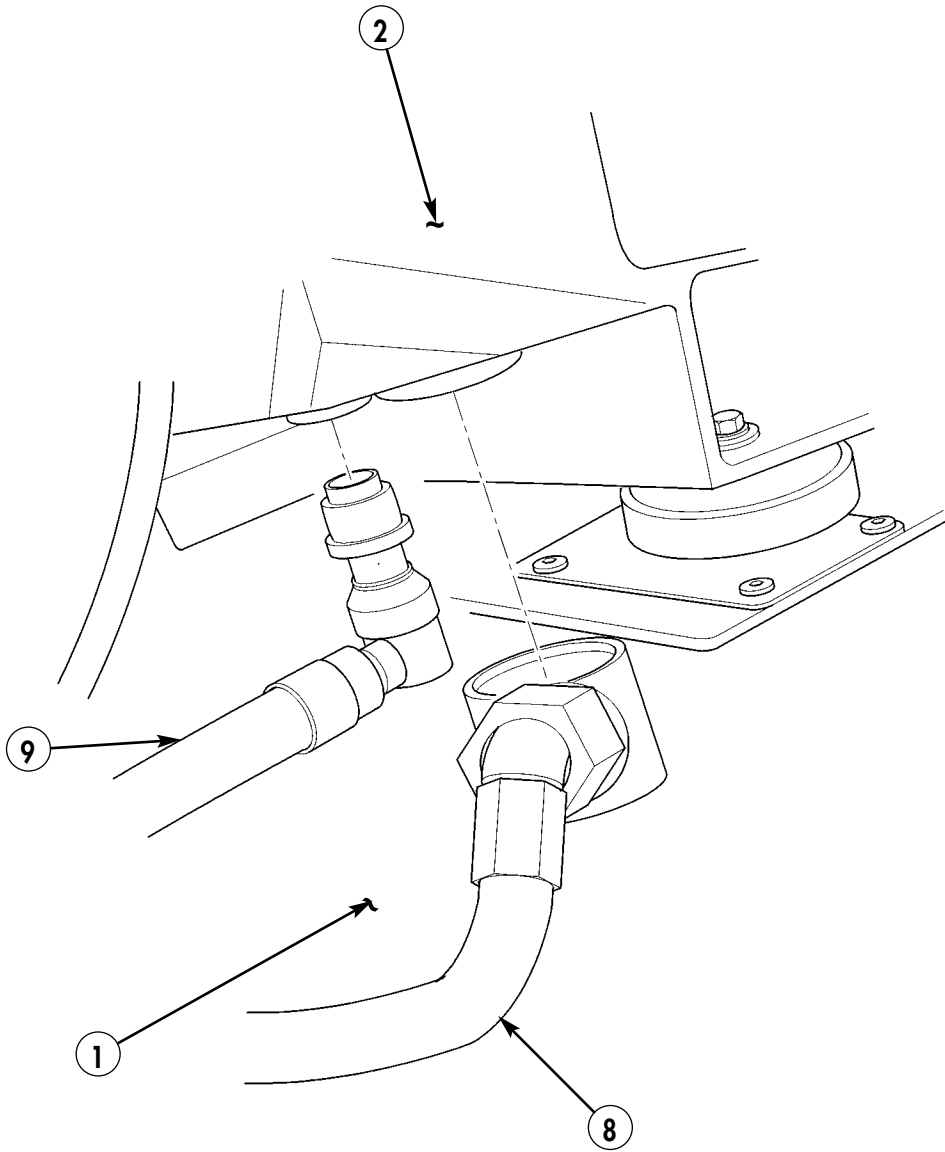

- 8. POWER CABLE – A3154857-1 – QTY. 1
- 9. CONTROL CABLE – A3210672-1 – QTY. 1

Figure 5-42.

18-6. Connect control cable (9) and power cable (8) to lower SINCGARS mounting base MT-6352/VRC (10).

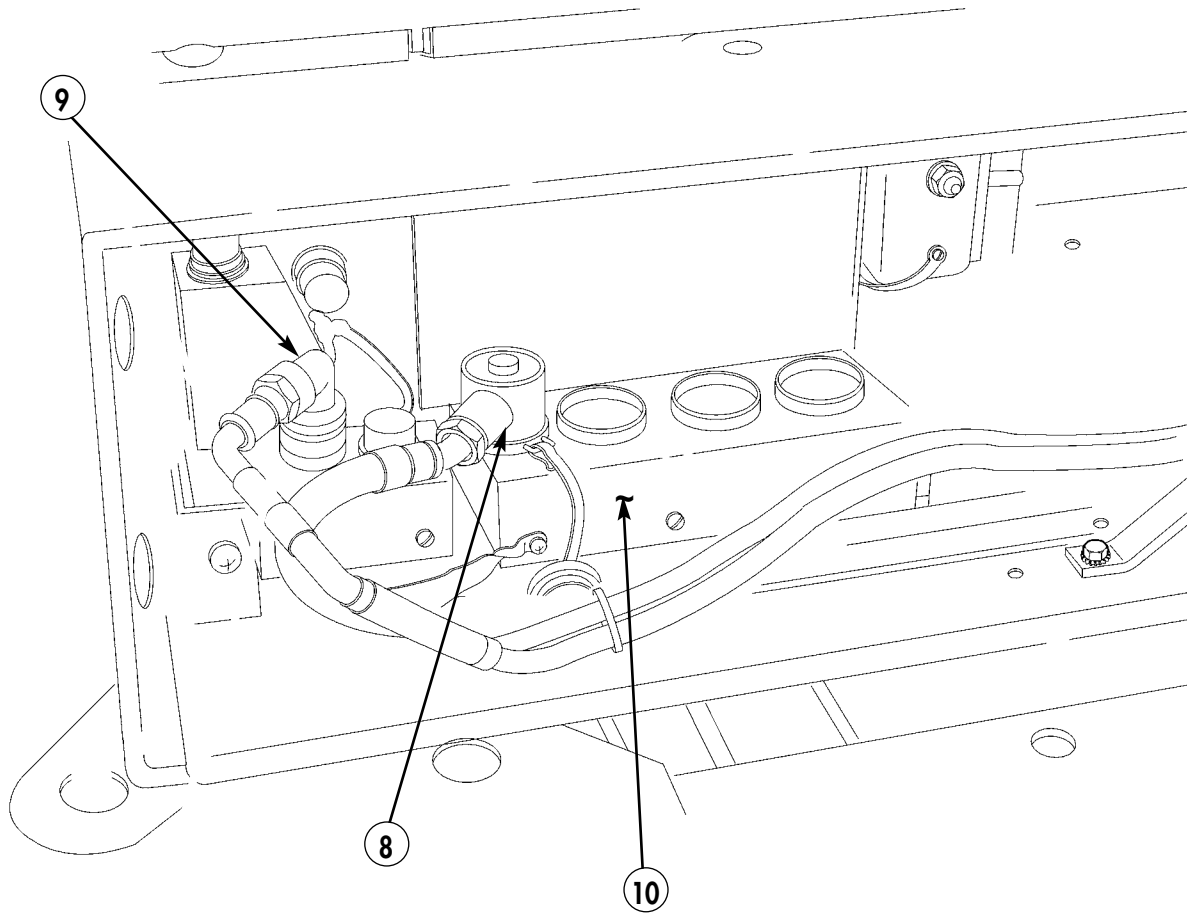

Figure 5-43.

### Section XIX. CHARGER INSTALLATION

19-1. Locate, mark, and drill four 0.266-in. diameter holes (2) in multi-net rack (1).

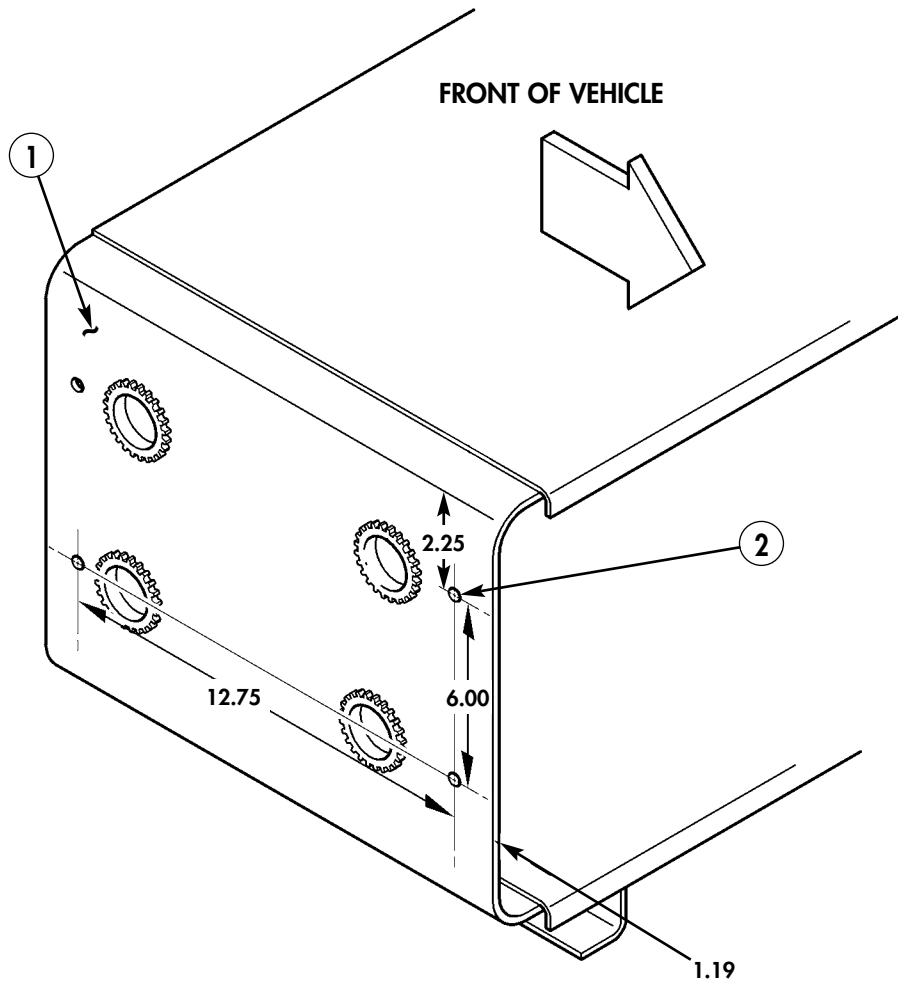
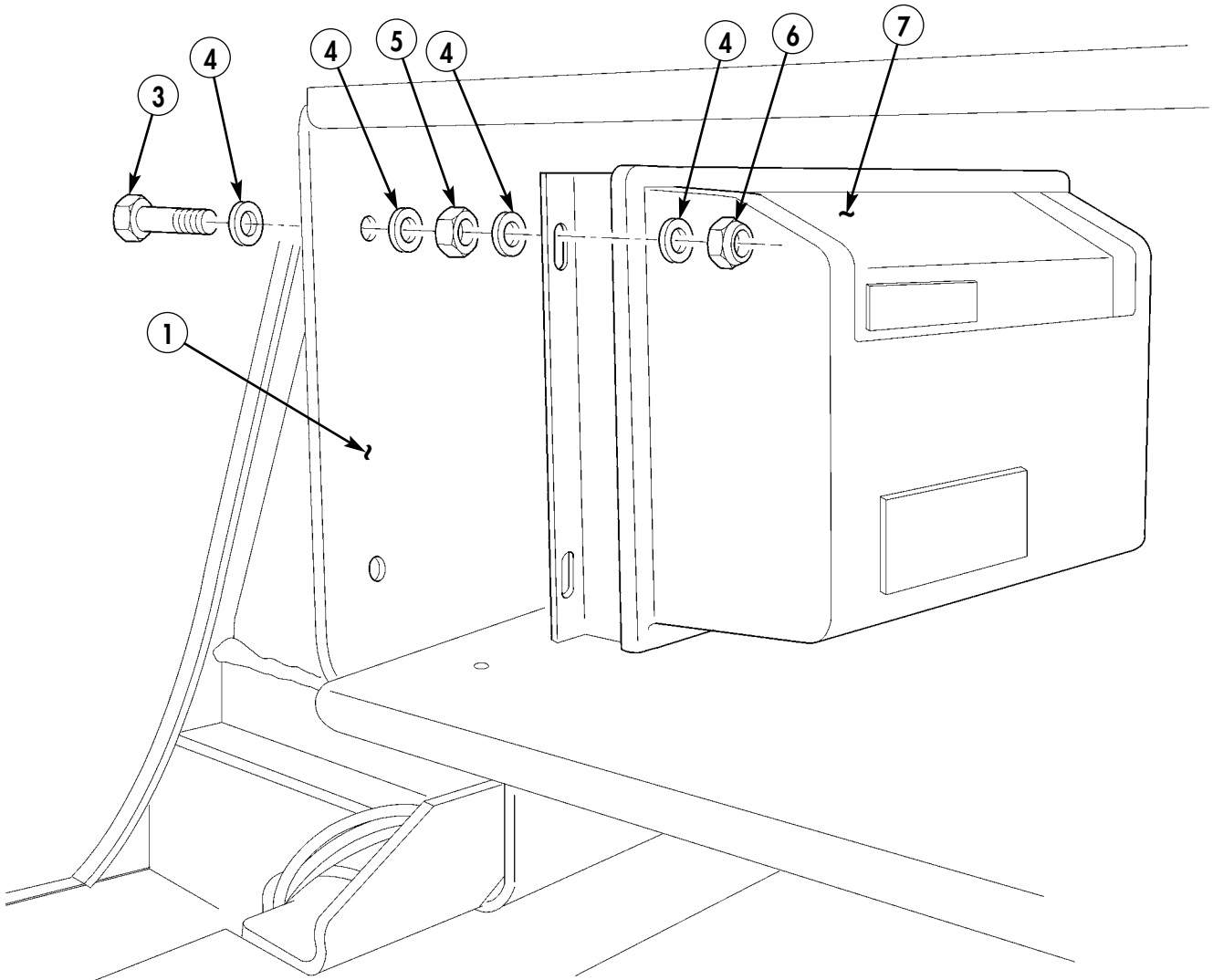

Figure 5-44.

- 19-2. Install charger (7) on multi-net rack (1) with four screws (3), sixteen washers (4), four nuts (5), and four locknuts (6).



- 3. SCREW - B1821BH025C150N - QTY. 4
- 4. WASHER - MS27183-10 - QTY. 16
- 5. NUT - MS51967-2 - QTY. 4
- 6. LOCKNUT - MS17829-4C - QTY. 4

Figure 5-45.

## Section XX. UPPER REAR SINGARS MOUNT INSTALLATION

- 20-1.** Remove paint from five existing holes (3) on multi-net rack (4). Apply anti-seize compound as required.
- 20-2.** Install SINGARS mount (2) to multi-net rack (4) with five capscrews (1), ten lockwashers (6), and five nuts (5).

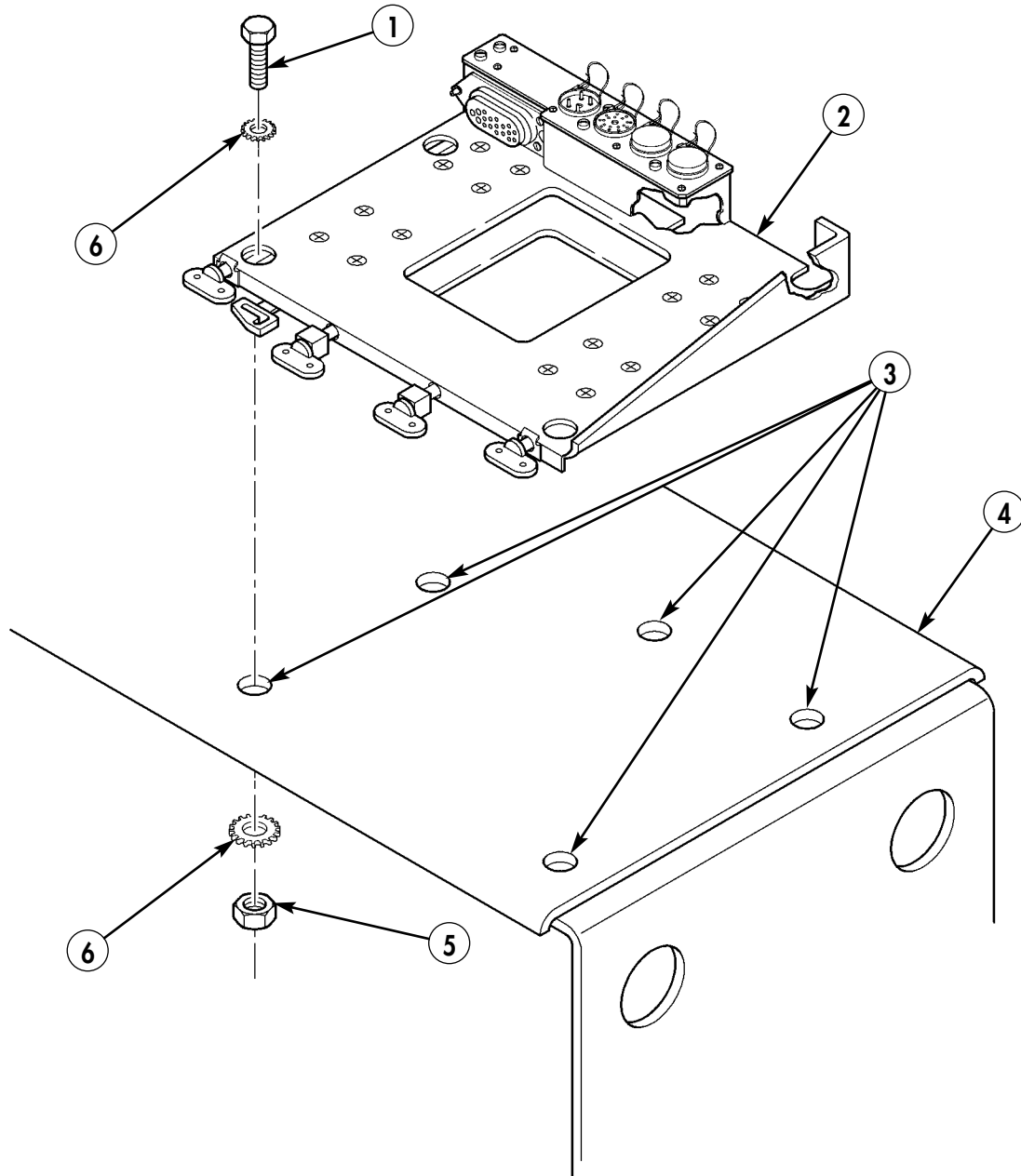

1. CAPSCREW – MS90726-36 – QTY. 5  
 2. MOUNTING BASE – MT-6352/VRC – A3013367-1 – QTY. 1  
 5. NUT – MS51968-5 – QTY. 5  
 6. LOCKWASHER – MS45904-72 – QTY. 10

Figure 5-46.

**Section XXI. POWER AMPLIFIER INSTALLATION ON UPPER SHELF OF MULTI-NET RACK**

- 21-1.** Using power amp mounting base MT6353/VRC (1) as template, locate, mark, and drill four 0.343-in. holes (5) in upper shelf of multi-net rack (7).
- 21-2.** Install power amp mounting base MT6353/VRC (1) on upper shelf of multi-net rack (7) with nut strip (2), two capscrews (4), and lockwashers (3).
- 21-3.** Secure power amp mounting base MT6353/VRC (1) on upper shelf of multi-net rack (7) with two capscrews (8), four lockwashers (3), and two nuts (6).

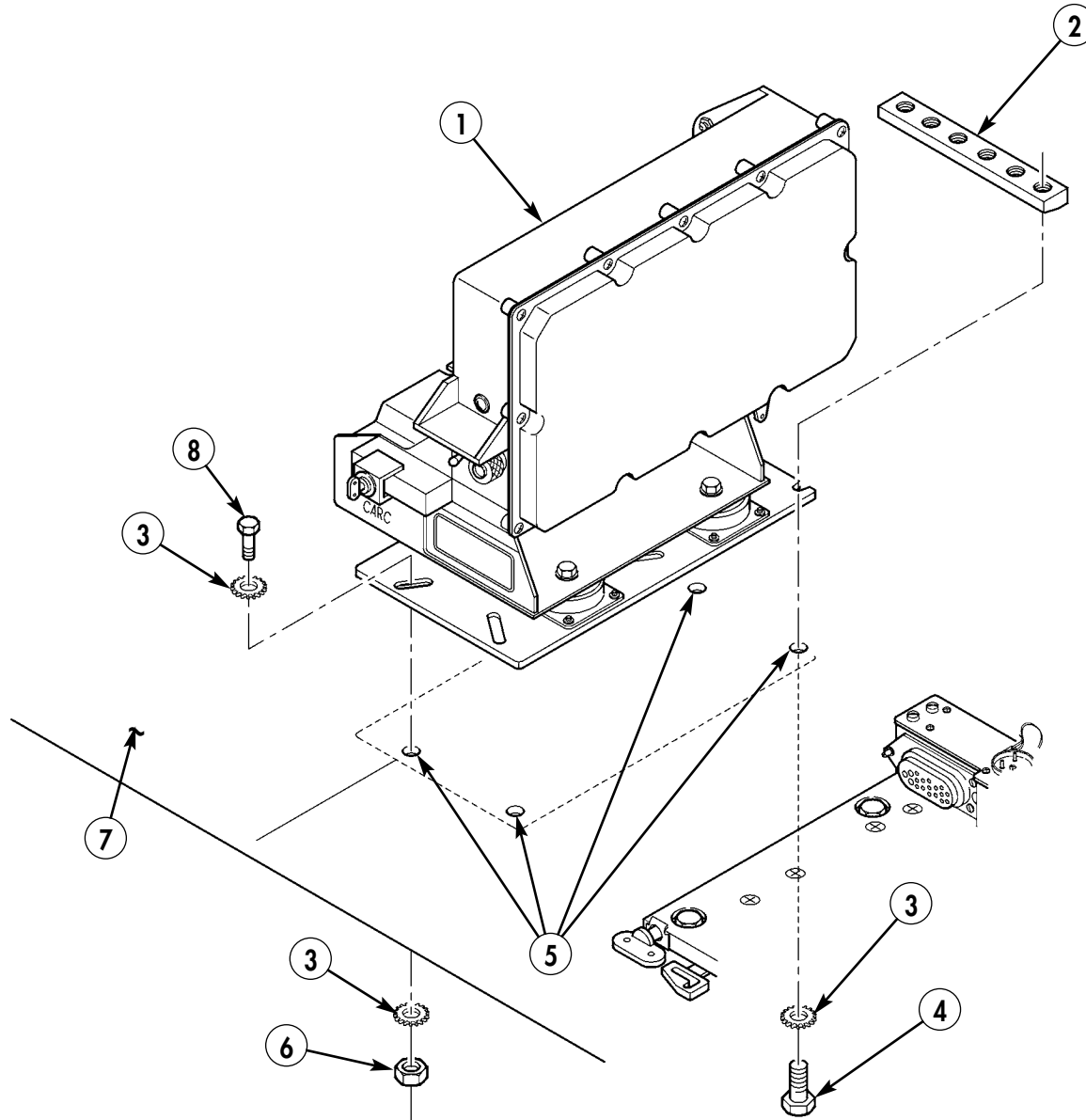

- 1. POWER AMP MOUNTING BASE, MT6353/VRC – A3014053-1 – QTY. 1**
- 2. NUT STRIP – A3014064-1 – QTY. 1**
- 3. LOCKWASHER – MS45904-72 – QTY. 6**
- 4. CAPSCREW – B1821BH031F125N – QTY. 2**
- 6. NUT – 9418892– QTY. 2**
- 8. CAPSCREW – B1821BH031F075N – QTY. 2**

Figure 5-47.

- 21-4. Route power cable (10) from power amp mounting base MT6353/VRC (1) around multi-net rack (4).
- 21-5. Route control cable (9) from power amp mounting base MT6353/VRC (1) around multi-net rack (4).

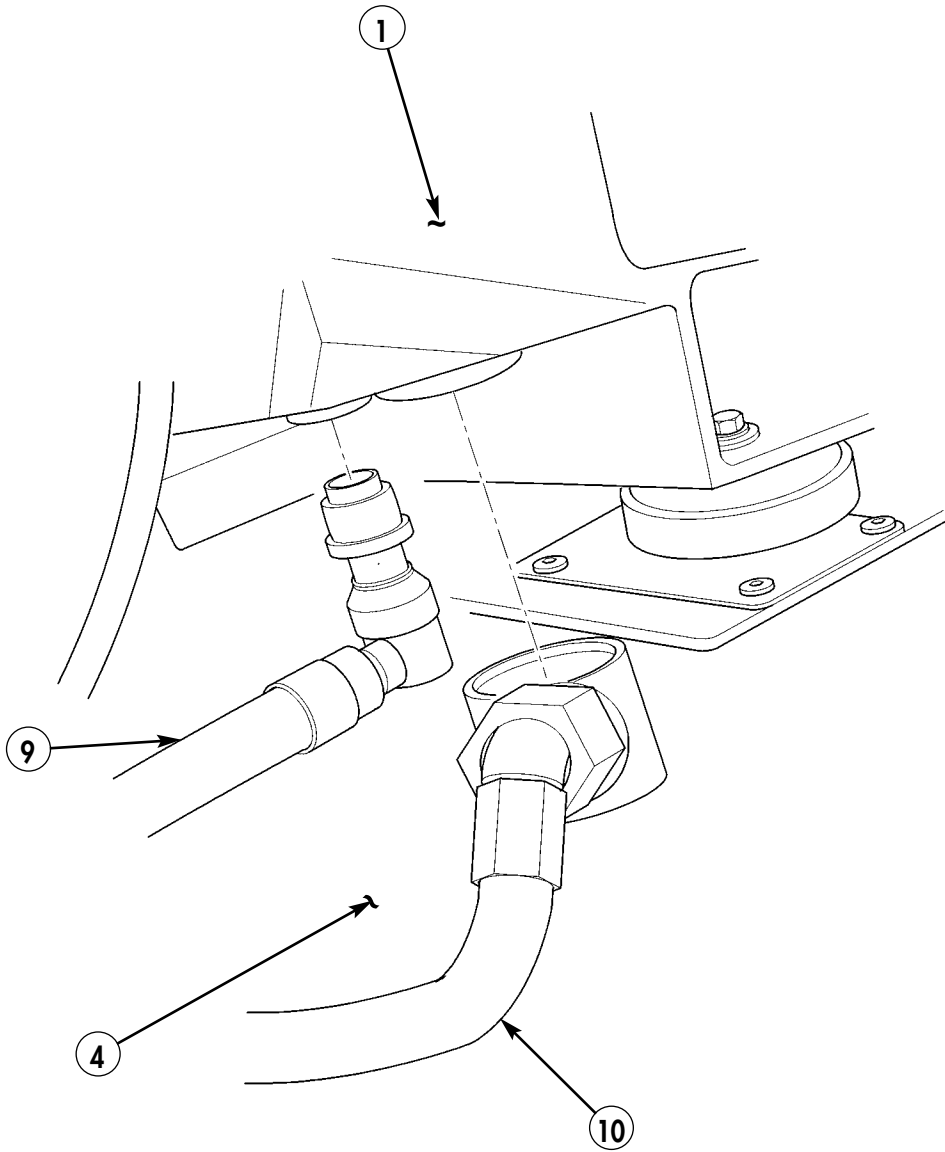

- 9. CONTROL CABLE - A3210672-1 - QTY. 1
- 10. POWER CABLE - A3154857-1 - QTY. 1

Figure 5-48.

21-6. Connect control cable (9) and power cable (10) to upper SINCGARS mounting base MT-6352/VRC (11).

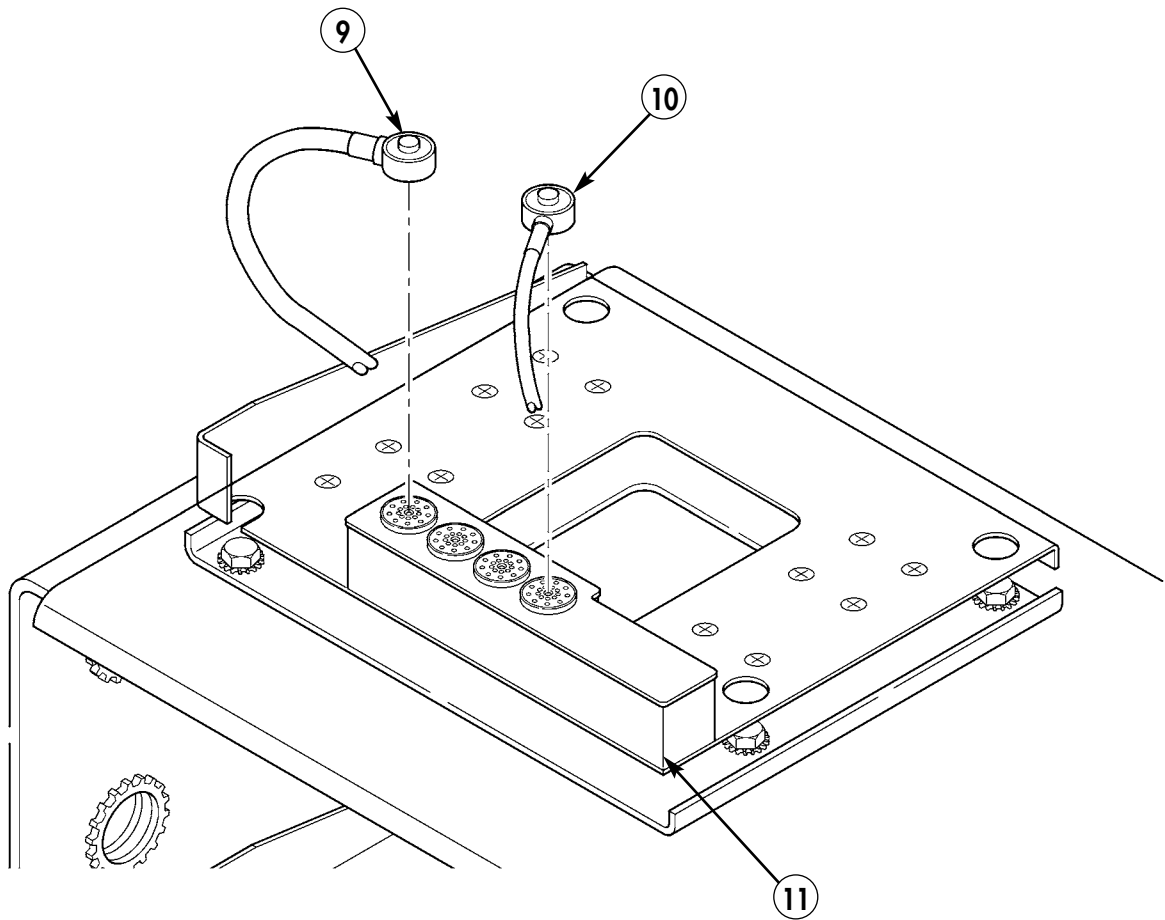
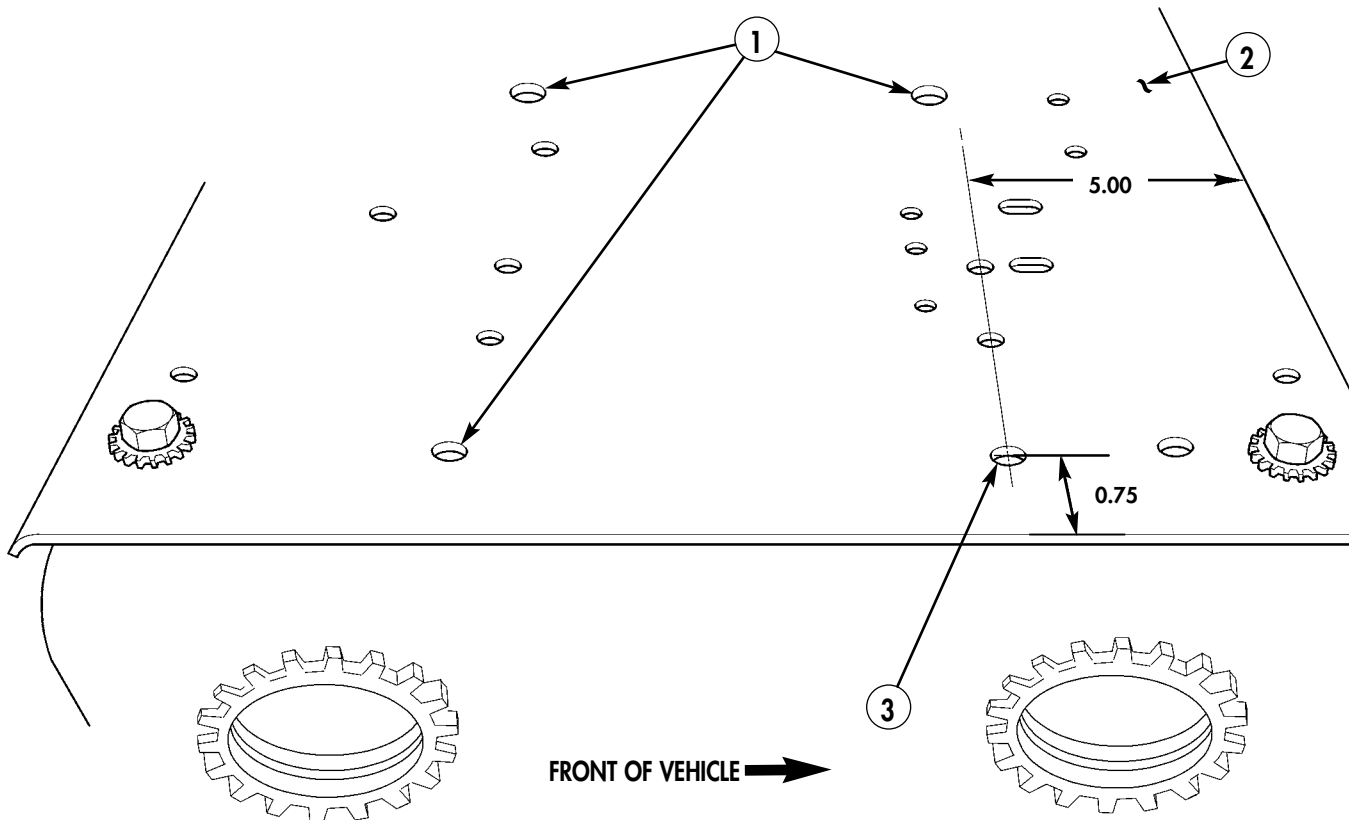

Figure 5-49.



**Section XXII. NTDR MOUNTING**

- 22-1.** Locate, mark, and drill one 0.343-in. diameter hole (3) in upper right shelf of multi-net rack (2).
- 22-2.** Using mounting tray as template, locate, mark, and drill three remaining 0.343-in. diameter holes (1) in upper right shelf of multi-net rack (2).
- 22-3.** Remove paint from mounting holes (1) and apply anti-seize compound as required.



*Figure 5-50.*

22-4. Install mounting tray (6) on upper right shelf of multi-net rack (2) with four capscrews (4), six lockwashers (5), two inserts (8), and nuts (7).

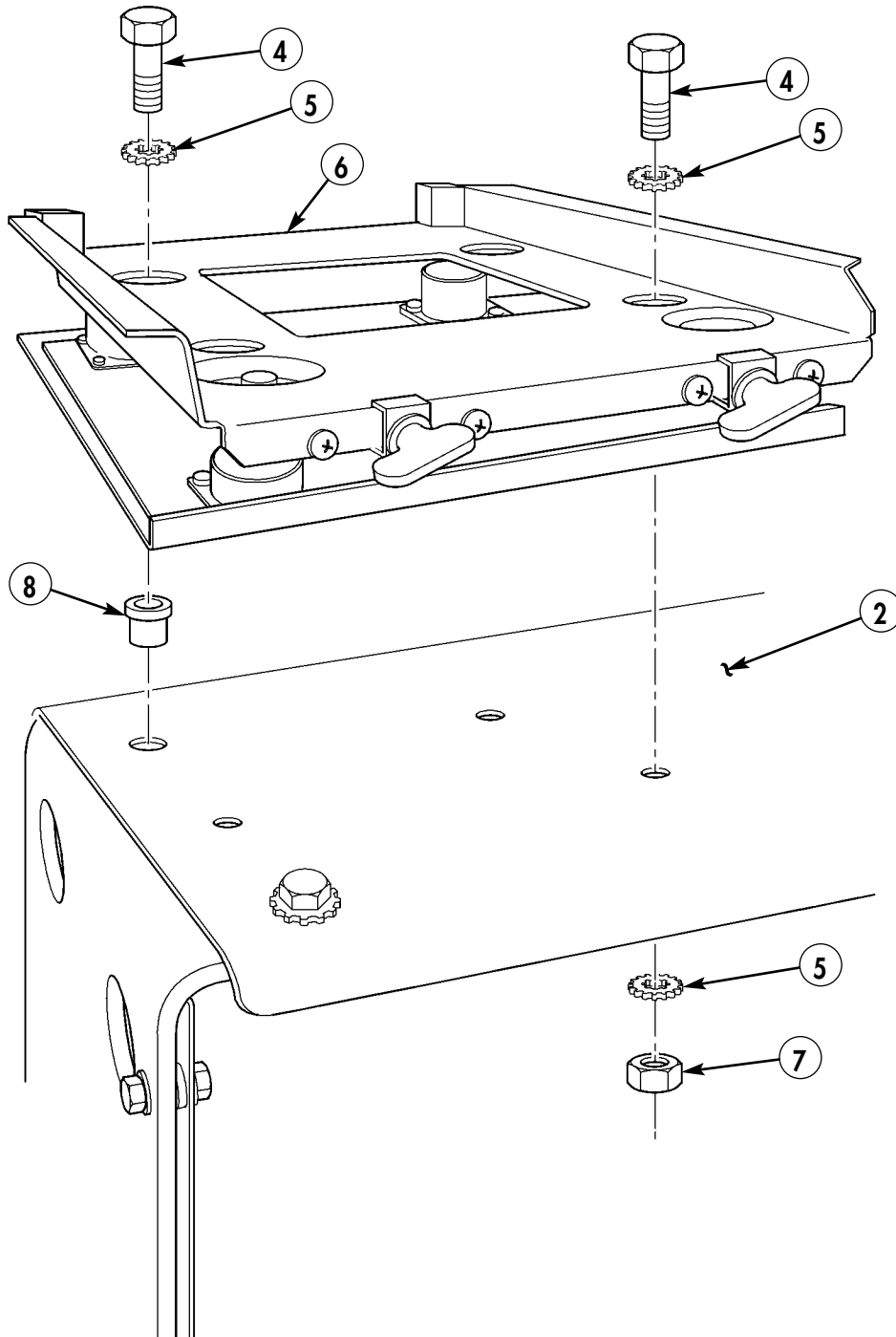

- 4. CAPSCREW – B1821BH031F125N – QTY. 4
- 5. LOCKWASHER – MS45904-72 – QTY. 6
- 6. TRAY, MOUNTING – 8174934G1 – QTY. 1
- 7. NUT – MS51968-5 – QTY. 2
- 8. INSERT – N/A – QTY. 2

Figure 5-51.

## Section XXIII. ANTENNA INSTALLATION

### NOTE

This procedure applies to vehicles without existing antennas, and to either left or right side of vehicle.

- 23-1.** Using antenna bracket (3) as template, locate, mark, and drill 1.375-in. diameter hole (2) in rear wall (4).
- 23-2.** Locate, mark, and drill three 0.343-in. diameter holes (1) in rear wall (4).
- 23-3.** Remove paint from vicinity of three holes (1) and three holes in antenna bracket (3).
- 23-4.** Apply anti-seize compound to vicinity of three holes (1) and rear of antenna bracket (3).

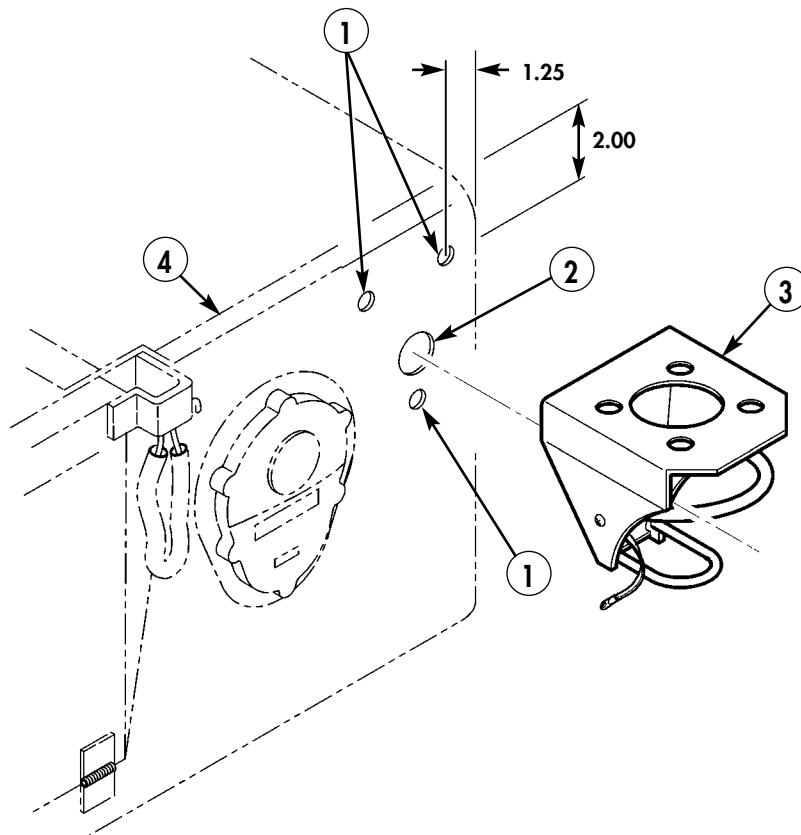

**3. ANTENNA MOUNTING BRACKET – A3014546-1 – QTY. 1**

*Figure 5-52.*

- 23-5. Install grommet (12) in hole (2) of rear wall (4).
- 23-6. Position antenna (13) and gasket (7) on antenna bracket (3) and route existing ground strap (9) through antenna bracket (3).
- 23-7. Install antenna (13) on antenna bracket (3) with four capscrews (5), eight lockwashers (6), and four nuts (8).
- 23-8. Install antenna bracket (3) on rear wall (4) with two capscrews (10), lockwashers (6), washers (14), and nuts (15).
- 23-9. Remove old terminal lug, and install new terminal lug (11) on ground strap (9). Install ground strap (9) and antenna bracket (3) on rear wall (4) with capscrew (10), lockwasher (6), washer (14), and nut (15).

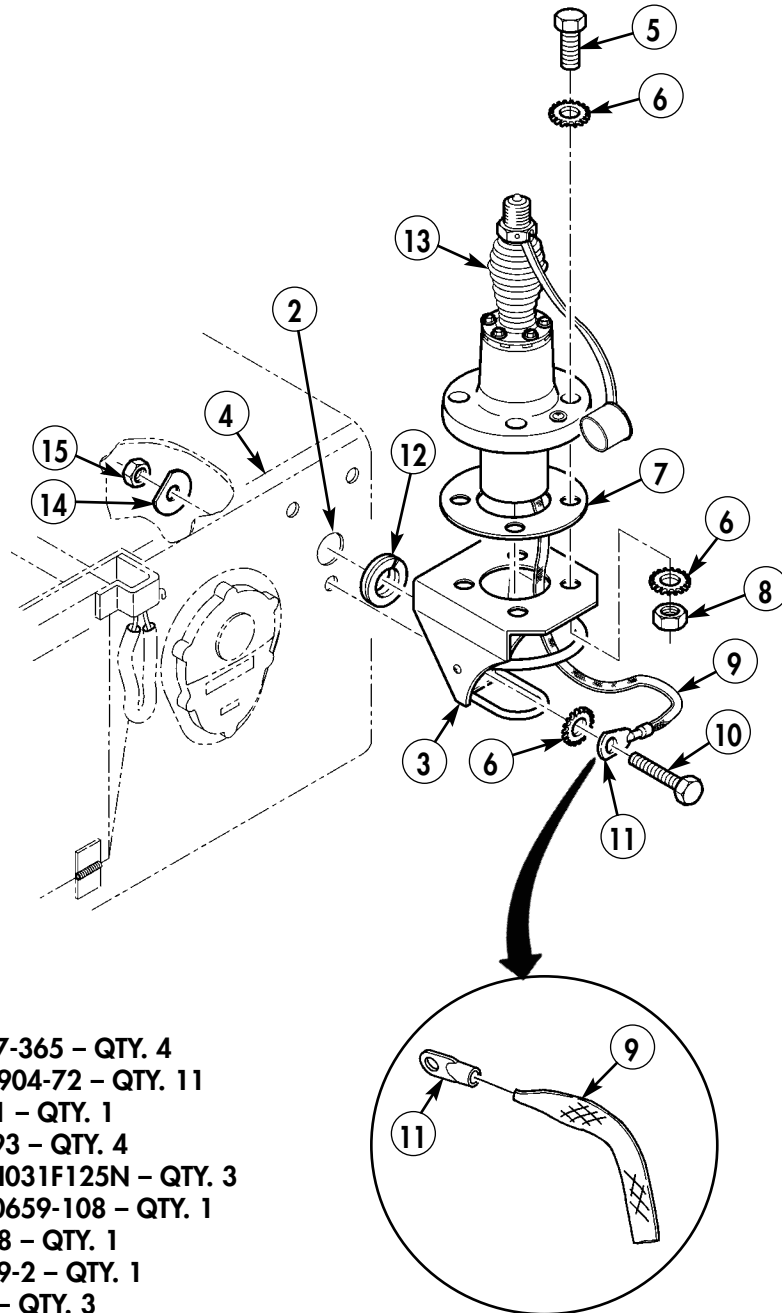

- 5. CAPSCREW – MS35307-365 – QTY. 4
- 6. LOCKWASHER – MS45904-72 – QTY. 11
- 7. GASKET – A3013655-1 – QTY. 1
- 8. NUT – 13218E0320-293 – QTY. 4
- 10. CAPSCREW – B1821BH031F125N – QTY. 3
- 11. TERMINAL LUG – MS20659-108 – QTY. 1
- 12. GROMMET – 12338098 – QTY. 1
- 13. ANTENNA – A3017899-2 – QTY. 1
- 14. WASHER – 12338095 – QTY. 3
- 15. NUT – 9418892 – QTY. 3

Figure 5-53.

- 23-10. Attach upper antenna element (16) to lower antenna element (18).
- 23-11. Attach antenna assembly to antenna base (13).
- 23-12. Attach fiber rope assembly (17) to upper antenna element (16).
- 23-13. Secure lower antenna element (18) to antenna base (13) with lockwire (19).
- 23-14. Repeat steps 23-1 through 23-13 for other side of vehicle, if applicable.

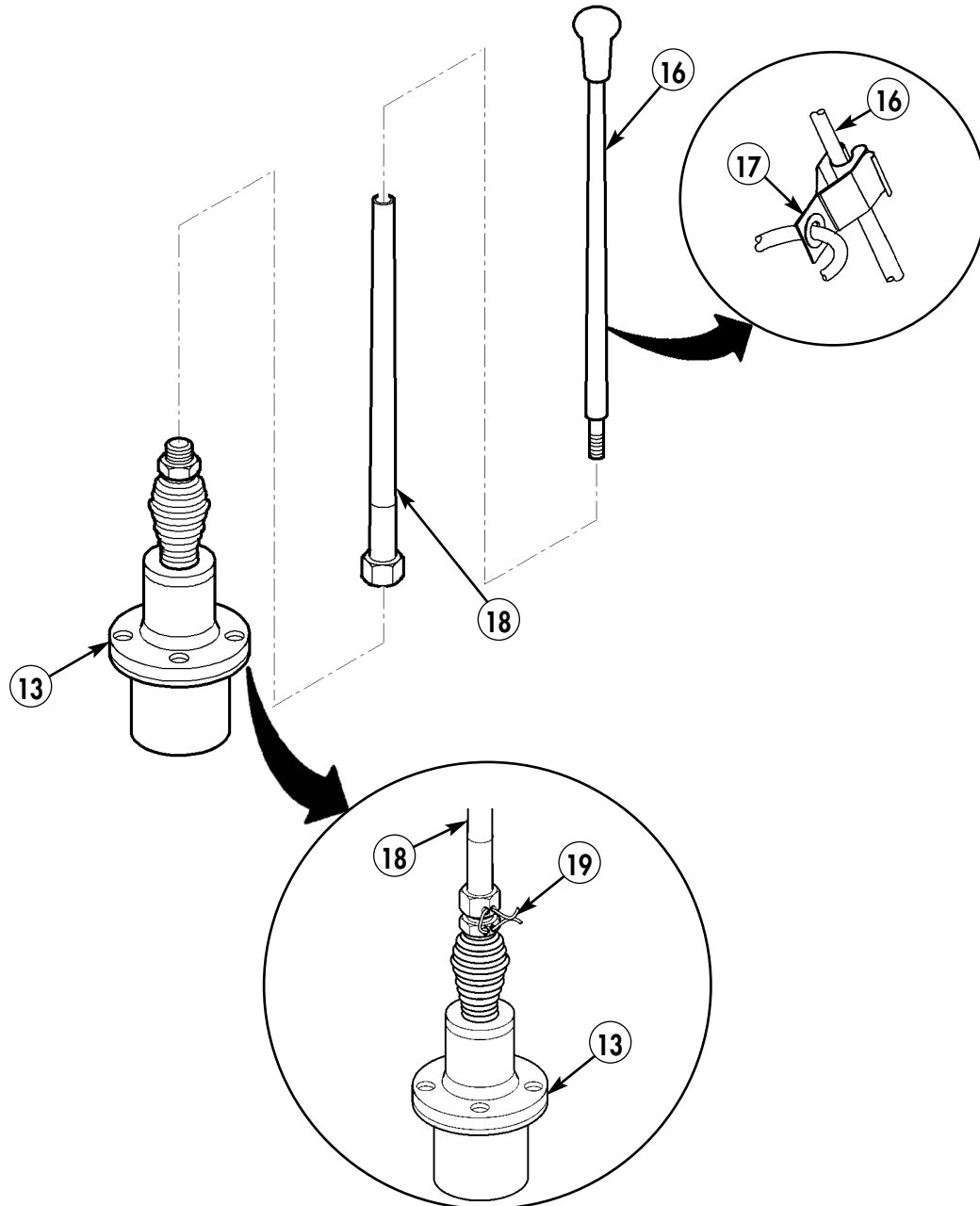

- 16. UPPER ANTENNA ELEMENT – A3017901-2 – QTY. 1
- 17. FIBER ROPE ASSEMBLY – A3167672-1 – QTY. 1
- 18. LOWER ANTENNA ELEMENT – A3018230-1 – QTY. 1
- 19. LOCKWIRE – MS20995C32 – QTY. A/R

Figure 5-54.

## Section XXIV. EPLRS MOUNTING BRACKET INSTALLATION

### NOTE

- Procedure may require removal of left rear side rail, which may require assistance. (Refer to TM 9-2320-280-20.)
- Grind any rivets on wheelhouse that will interfere with installation of EPLRS mounting plate.

**24-1.** Remove left rear side rail if necessary (TM 9-2320-280-20).

**24-2.** Install positioning plate (3) on wheelhouse (4) with two capscrews (1), four washers (2), and two nuts (5).

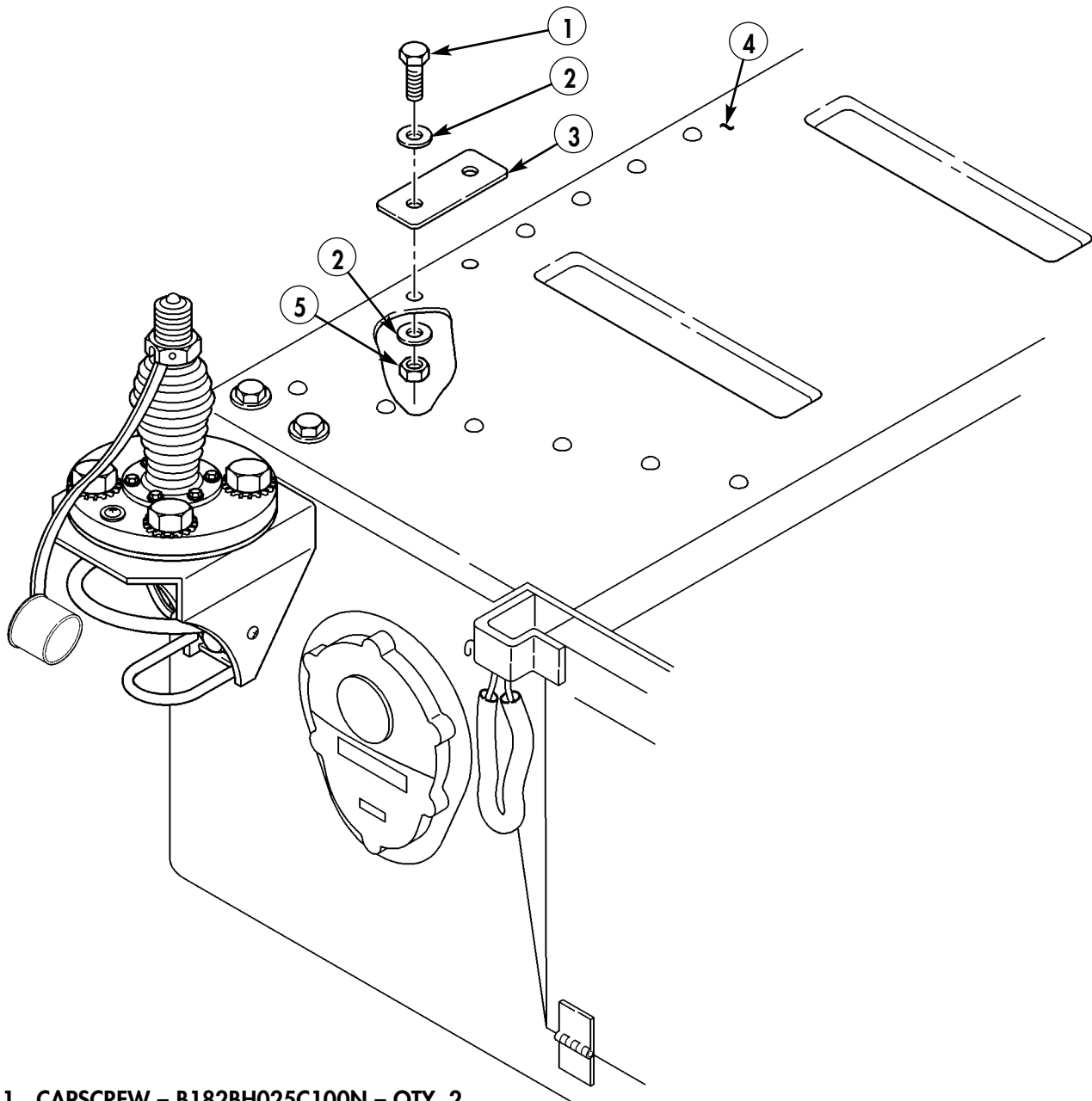

1. CAPSCREW - B182BH025C100N - QTY. 2
2. WASHER - MS27183-10 - QTY. 2
3. PLATE, PLACEMENT - A3046203 - QTY. 1
5. NUT - MS51967-2 - QTY. 2

Figure 5-55.

- 24-3. Using mounting plate (6) as template, locate, mark, and drill four 0.343-in. diameter holes (14) and four 0.281-in. diameter holes (19) in left rear wheelhouse (4).
- 24-4. Remove two sections (8) from mounting plate (6).
- 24-5. Remove paint from vicinity of sixteen mounting holes (7) on mounting plate (6).

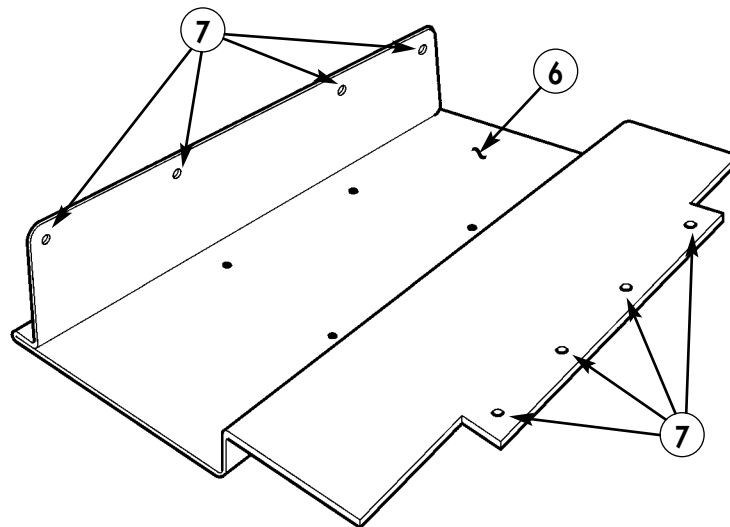
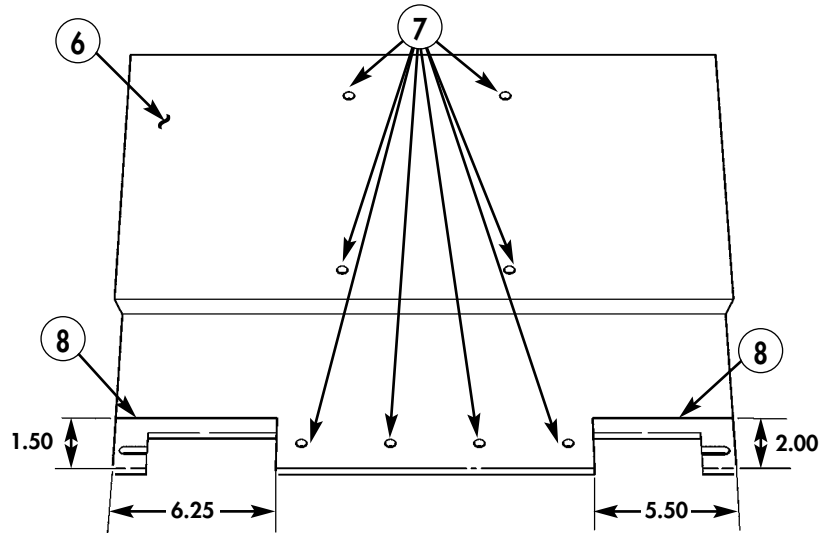

6. MOUNTING PLATE, EPLRS – A3046204 – QTY. 1

Figure 5-56.

- 24-6. Install resilient mount (12) on mounting plate (6) with four capscrews (11), eight lockwashers (10), and four nuts (13).
- 24-7. Remove paint from vicinity of eight mounting holes (19) and (14) on left rear wheelhouse (4). Apply anti-seize compound as required. Position mounting plate (6) on left rear wheelhouse (4) and align all holes.
- 24-8. Install mounting plate (6) on left rear wheelhouse (4) with four capscrews (9), washers (18), lockwashers (17), and nuts (16).
- 24-9. Secure mounting plate (6) to left rear wheelhouse (4) with four capscrews (11), lockwashers (10), spacers (15), lockwashers (10) and nuts (13).
- 24-10. Remove two capscrews (1), four washers (2), and two nuts (5) from positioning plate (3) and left rear wheelhouse (4).

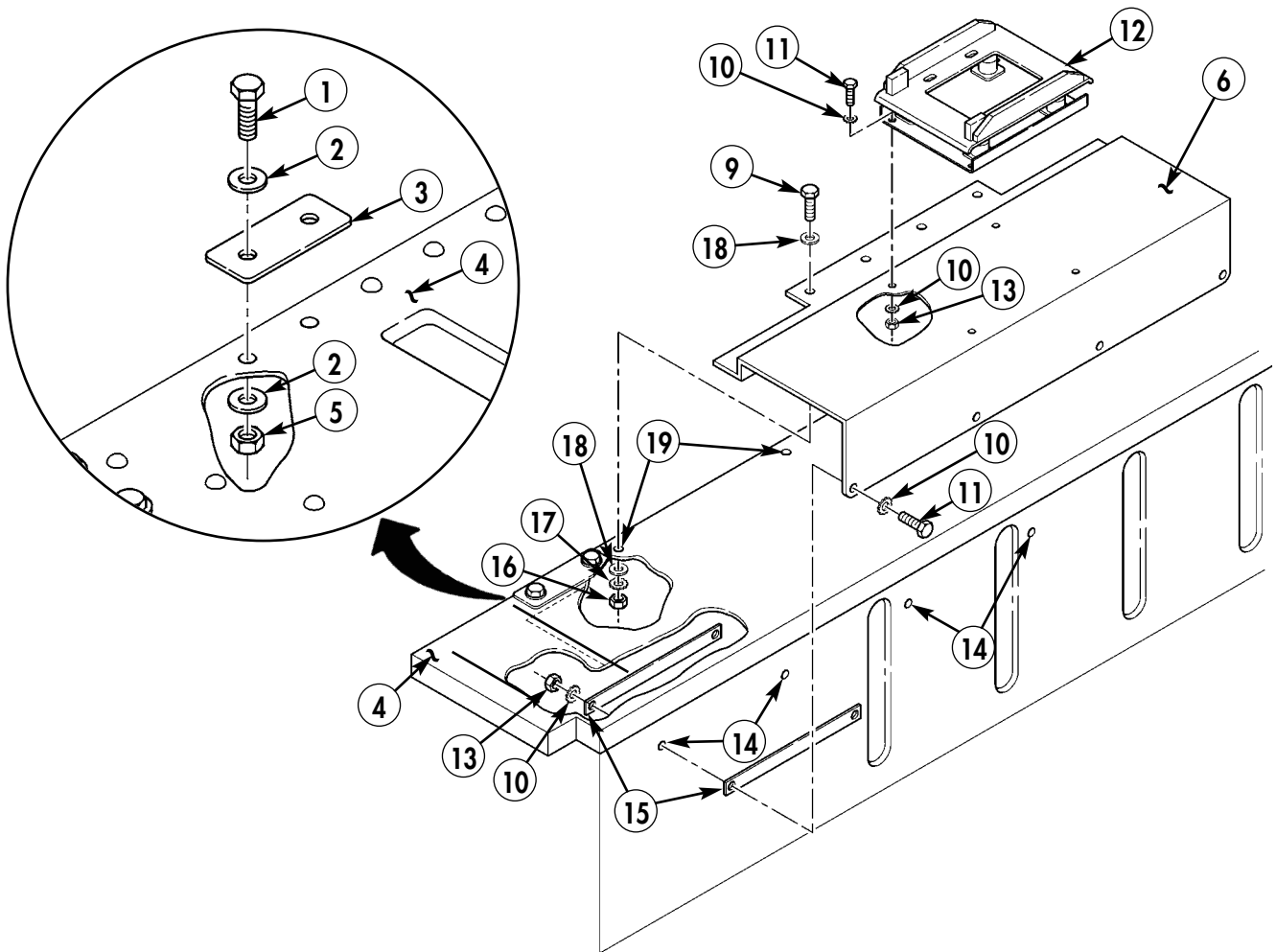

- 9. CAPSCREW - B1821BH025C125N - QTY. 4
- 10. LOCKWASHER - MS45904-72 - QTY. 16
- 11. CAPSCREW - B1821BH031C100N - QTY. 8
- 12. RESILIENT MOUNT - MT-6146/VSQ-1 - QTY. 1
- 13. NUT - 9417954 - QTY. 8
- 15. SPACER - A3046313 - QTY. 4
- 16. NUT - 9419143 - QTY. 4
- 17. LOCKWASHER - MS35338-44 - QTY. 4
- 18. WASHER - 2436161 - QTY. 8

Figure 5-57.



## Section XXV. SINGARS PEDESTAL ANTENNA MOUNT INSTALLATION

- 25-1.** Assemble antenna mounting bracket (3) and antenna base reinforcement bracket (4) with eight capscrews (1), sixteen lockwashers (2), and eight nuts (5). Do not tighten nuts (5) at this time.

### NOTE

Remove paint or tape from mounting holes.

- 25-2.** Remove paint from vicinity of all mounting holes on both antenna plates, antenna mount assembly, and ground strap. Apply anti-seize compound as required.

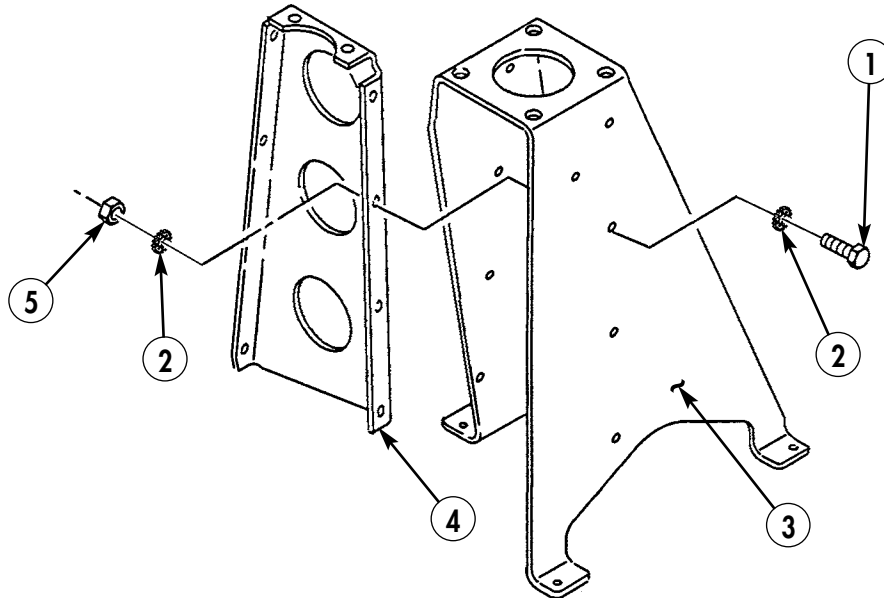

1. CAPSCREW – B1821BH025C100N – QTY. 8
2. LOCKWASHER – MS35338-44 – QTY. 16
3. ANTENNA MOUNTING BRACKET – A3018371-2 – QTY. 1
4. ANTENNA BASE REINFORCEMENT BRACKET – A3018372-2 – QTY. 1
5. NUT – MS51967-2 – QTY. 8

*Figure 5-58.*

**NOTE**

- Remove right rear side rail, if necessary. (Refer to TM 9-2320-280-20.)
- Front edge of upper antenna plate should be approximately 9.75 in. from edge of front bolts in wheelhouse.

- 25-3.** Locate screw (11) on right rear wheelhouse (8) and drill out rivet (10) from right rear wheelwell (8). Enlarge hole to 0.281 in.
- 25-4.** Position support plate (12) underneath wheelhouse (8) and drill two 0.281-in. diameter holes (13).
- 25-5.** Using upper antenna plate (6) as template, locate, mark, and drill thirteen 0.281-in. holes (7) and three 0.408-in. holes (9) in left rear wheelhouse (8).

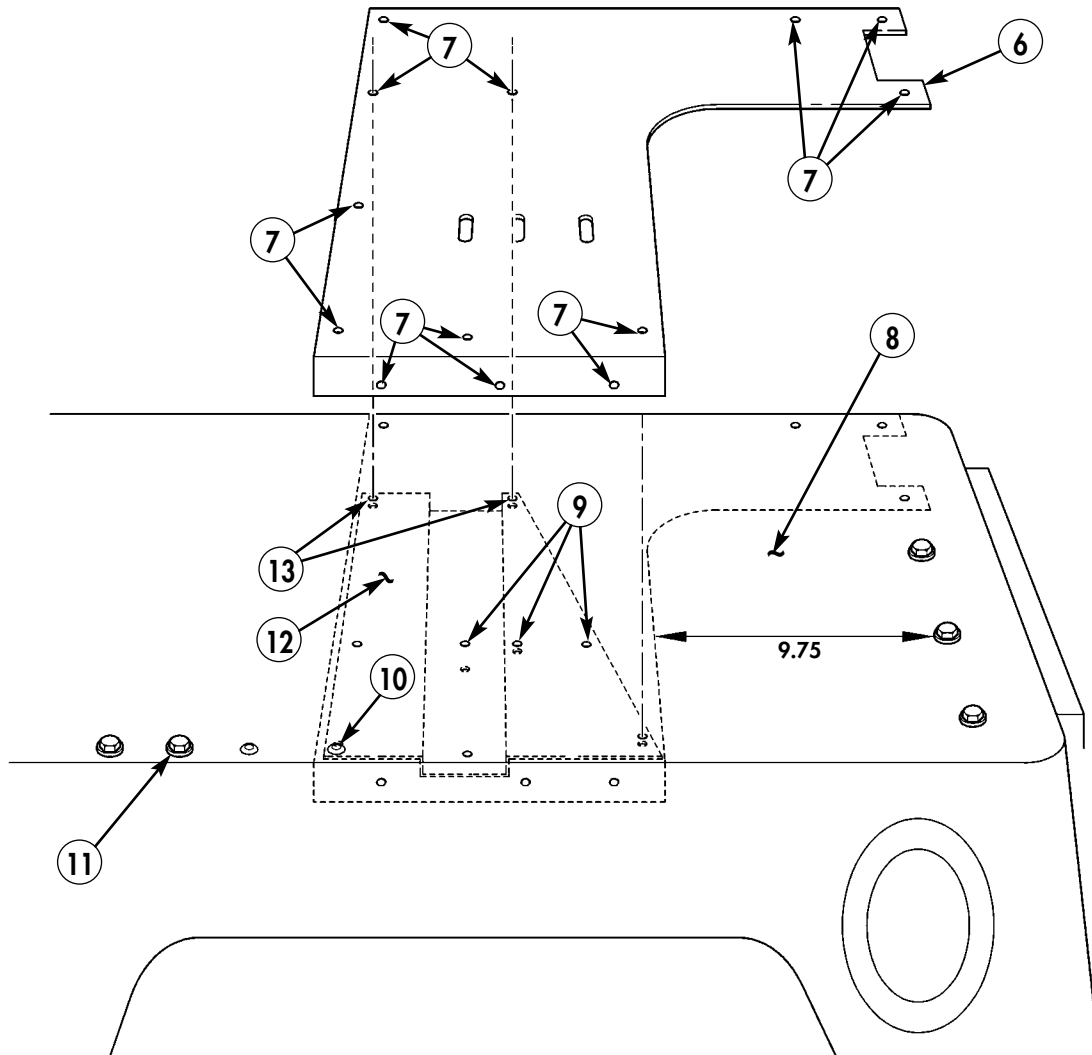

**6. ANTENNA PLATE - A3104004-2 - QTY. 1**

*Figure 5-59.*

**NOTE**

Enlarge hole on antenna mount assembly to accommodate 7/16-in. bolts.

- 25-6.** Install antenna mount assembly (25), upper antenna plate (6), and lower antenna plate (17) on left rear wheelhouse (8) with eleven capscrews (23), twenty-two washers (22), eleven lockwashers (21), and nuts (20).
- 25-7.** Install antenna mount assembly (25), upper antenna plate (6), and lower antenna plate (17) on left rear wheelhouse (8) with two capscrews (14), four washers (15), two lockwashers (18), and nuts (19).
- 25-8.** Secure antenna mount assembly (25), upper antenna plate (6), and lower antenna plate (17) to left rear wheelhouse (8) with two capscrews (24), four washers (22), two lockwashers (21), and nuts (20).
- 25-9.** Secure antenna mount assembly (25), upper antenna plate (6), and lower antenna plate (17) to left rear wheelhouse (8) with capscrew (16), two washers (15), lockwasher (18), and nut (19).

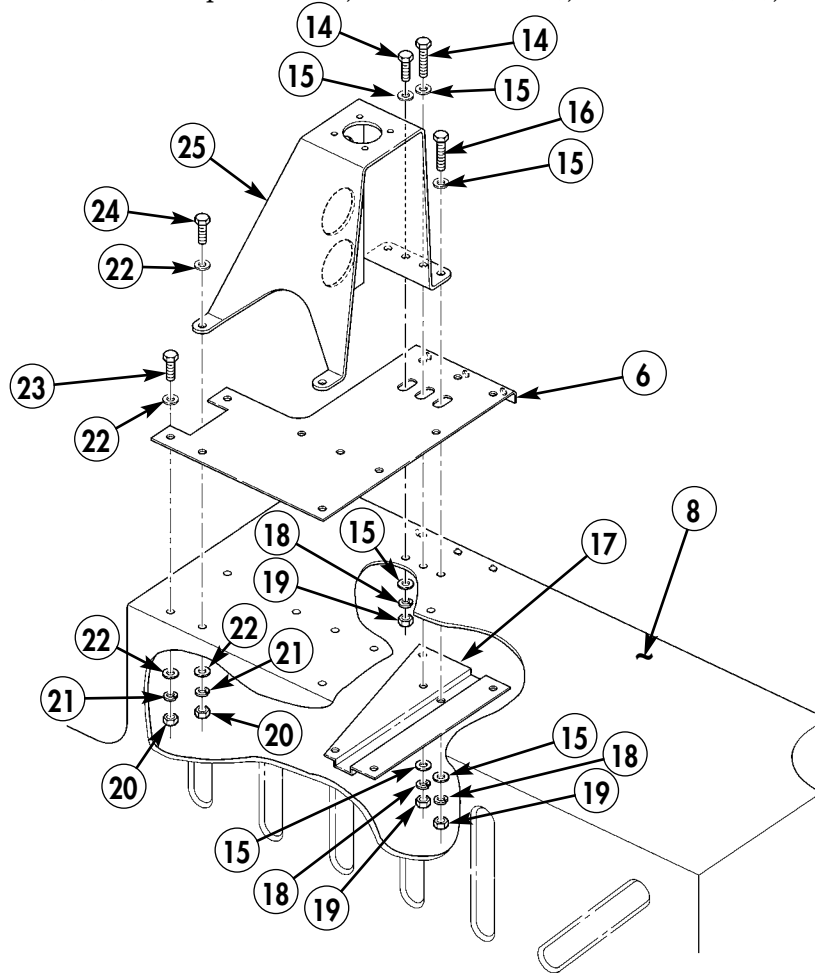

14. CAPSCREW - B1821BH044C125N - QTY. 2  
 15. WASHER - 2436163 - QTY. 6  
 16. CAPSCREW - B1821BH044C150N - QTY. 1  
 17. ANTENNA PLATE - A3157619 - QTY. 1  
 18. LOCKWASHER - 120382 - QTY. 3  
 19. NUT - 13218E0320-293 - QTY. 3

20. NUT - 9419143 - QTY. 13  
 21. LOCKWASHER - MS35338-44 - QTY. 13  
 22. WASHER - 2436161 - QTY. 26  
 23. CAPSCREW - B1821BH025C100N - QTY. 11  
 24. CAPSCREW - B1821BH025C150N - QTY. 2

Figure 5-60.

**NOTE**

Perform step 25-10 only if not installing cargo soft-top enclosure; otherwise, start with step 25-11.

- 25-10.** Install antenna (27) on antenna mount assembly (25) with four capscrews (26), gasket (28), eight lockwashers (33), and four nuts (32).

**NOTE**

Perform steps 25-11 and 25-12 only when installing cargo soft-top enclosure.

- 25-11.** Install cargo soft-top enclosure (34). (Refer to TM 9-2320-280-10.)

**NOTE**

Ensure all slack has been taken out of cargo soft-top enclosure, and that cargo soft-top enclosure has been properly installed.

- 25-12.** Using antenna (27) as template, locate, mark, and drill four 0.375-in. holes (35) and cut "X" (36) in cargo soft-top enclosure (34).

- 25-13.** Install antenna (27) on antenna mount assembly (25) and cargo soft-top enclosure (34) with four capscrews (26), gasket (28), eight lockwashers (33), and four nuts (32), ensuring that ground strap (31) is inserted through cut hole (36).

- 25-14.** Install ground strap (31) on antenna mount assembly (25) with screw (30), three lockwashers (29), and nut (20).

- 25-15.** Tighten all nuts (20) and (32).

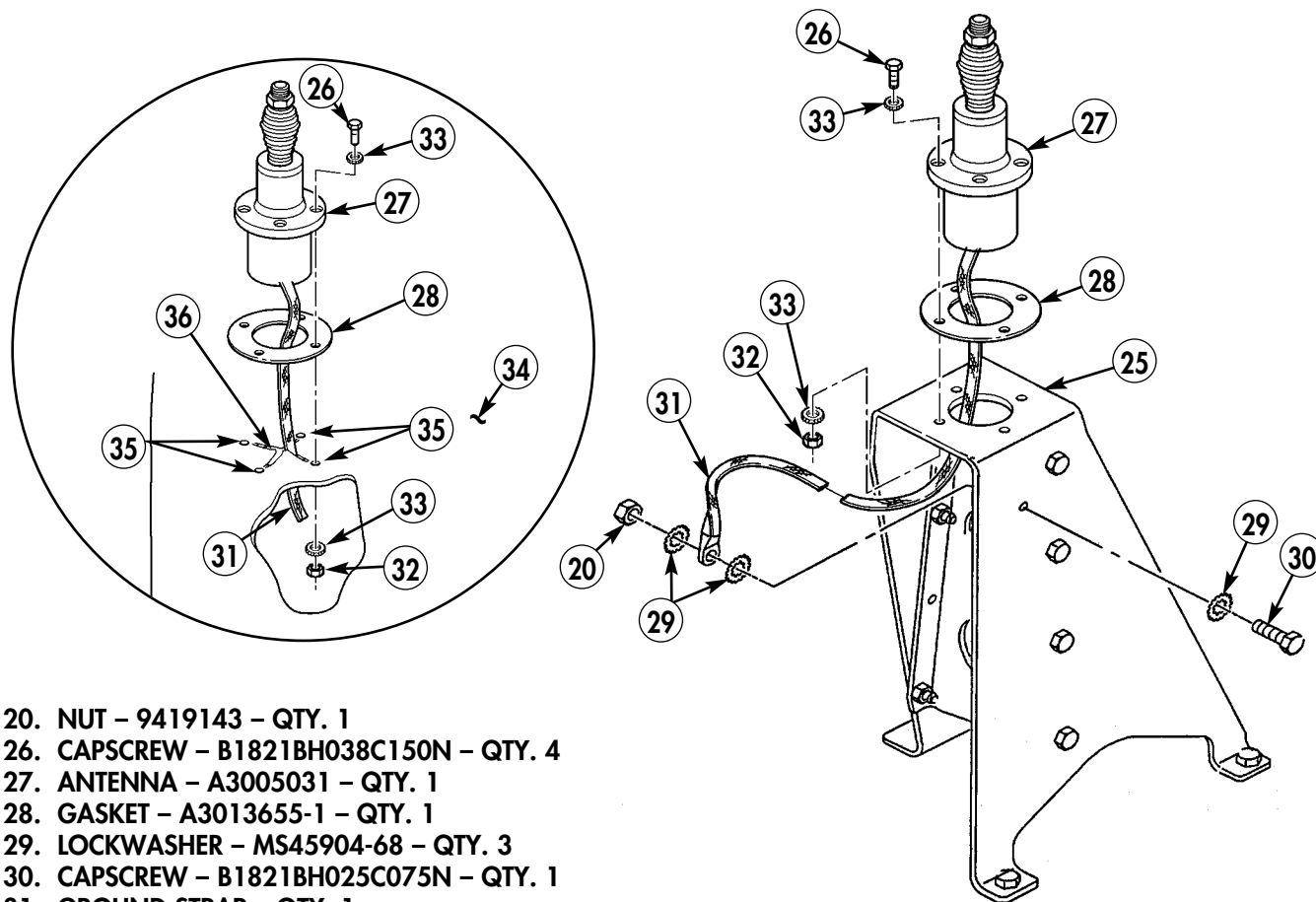

- 20. NUT - 9419143 - QTY. 1
- 26. CAPSCREW - B1821BH038C150N - QTY. 4
- 27. ANTENNA - A3005031 - QTY. 1
- 28. GASKET - A3013655-1 - QTY. 1
- 29. LOCKWASHER - MS45904-68 - QTY. 3
- 30. CAPSCREW - B1821BH025C075N - QTY. 1
- 31. GROUND STRAP - QTY. 1
- 32. NUT - 13218E0320-293 - QTY. 4
- 33. LOCKWASHER - MS45904-76 - QTY. 8

Figure 5-61.

- 25-16. Attach upper antenna element (37) to lower antenna element (39).
- 25-17. Attach antenna assembly to antenna base (27).
- 25-18. Attach fiber rope assembly (38) to upper antenna element (37).
- 25-19. Secure lower antenna element (39) to antenna base (27) with lockwire (40).

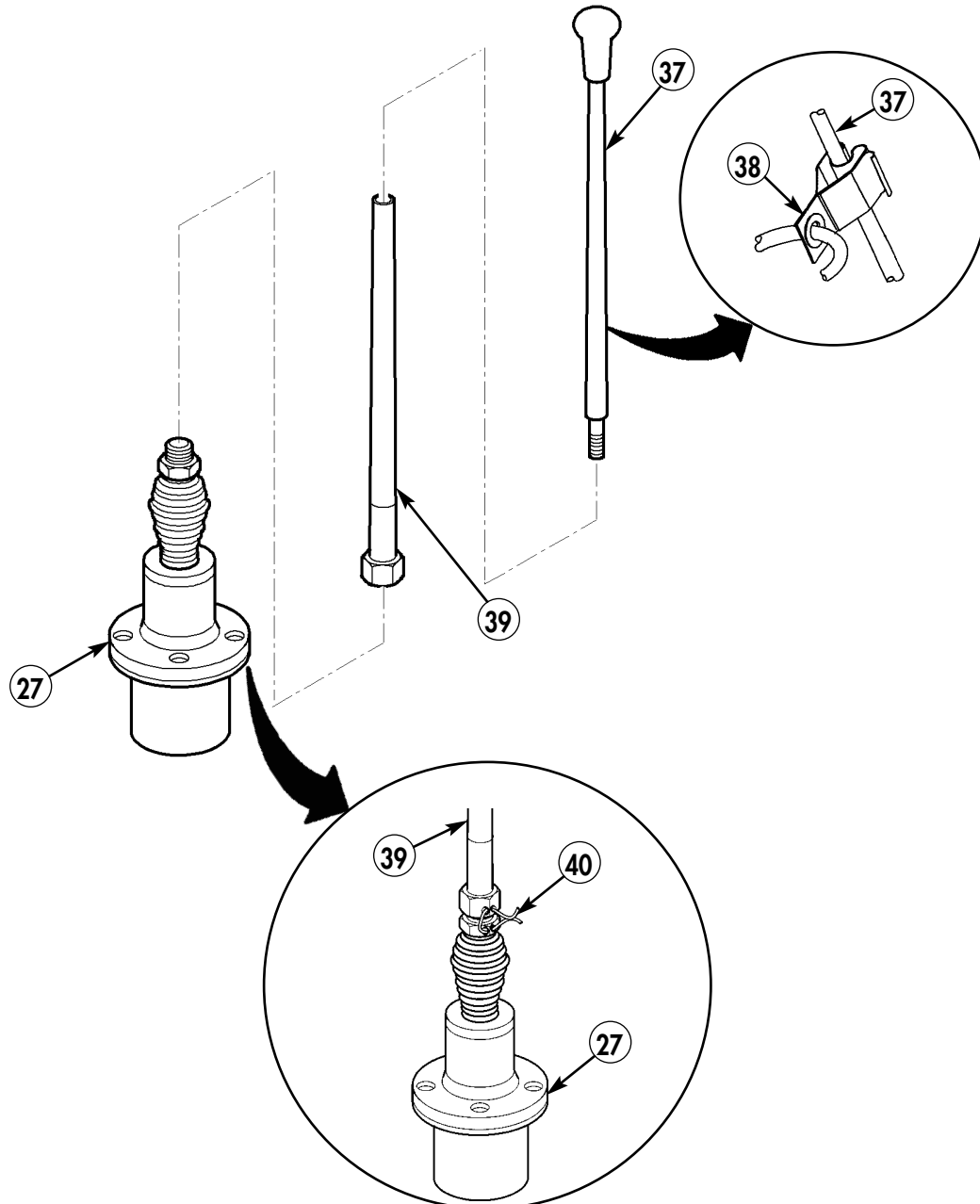

- 37. UPPER ANTENNA ELEMENT – A3017901-2 – QTY. 1
- 38. FIBER ROPE ASSEMBLY – A3167672-1 – QTY. 1
- 39. LOWER ANTENNA ELEMENT – A3018230-1 – QTY. 1
- 40. LOCKWIRE – MS20995C32 – QTY. A/R

Figure 5-62.

### Section XXVI. EPLRS PEDESTAL ANTENNA MOUNT AND NTRD ANTENNA INSTALLATION

- 26-1. Assemble antenna mounting bracket (3) and antenna base reinforcement bracket (4) with eight capscrews (1), sixteen lockwashers (2), and eight nuts (5). Do not tighten nuts (5) at this time.
- 26-2. Remove paint from vicinity of all mounting holes on both antenna plates, antenna mount assembly, and ground strap. Apply anti-seize compound as required.

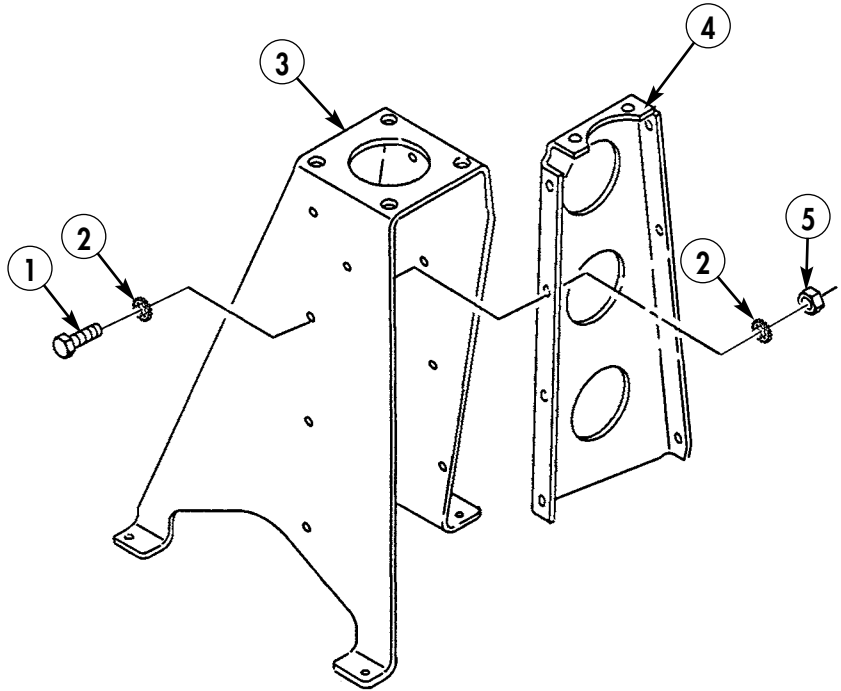

- 1. CAPSCREW – B1821BH025C100N – QTY. 8
- 2. LOCKWASHER – MS35338-44 – QTY. 16
- 3. ANTENNA MOUNTING BRACKET – A3018371-1 – QTY. 1
- 4. ANTENNA BASE REINFORCEMENT BRACKET – A3018372-1 – QTY. 1
- 5. NUT – MS51967-2 – QTY. 8

Figure 5-63.

**NOTE**

- Remove left rear side rail, if necessary.  
(Refer to TM 9-2320-280-20.)
- Front edge of upper antenna plate should be approximately 9.75 in. from edge of front bolts in wheelhouse.

- 26-3.** Locate screw (9) on left rear wheelhouse (13), and drill out rivet (10) from left rear wheelhouse (13). Enlarge hole to 0.281 in.
- 26-4.** Position support plate (8) underneath wheelhouse (13) and drill two 0.281-in. diameter holes (11).
- 26-5.** Using upper antenna plate (6) as template, locate, mark, and drill thirteen 0.281-in. holes (7) and three 0.408-in. holes (12) in left rear wheelhouse (13).

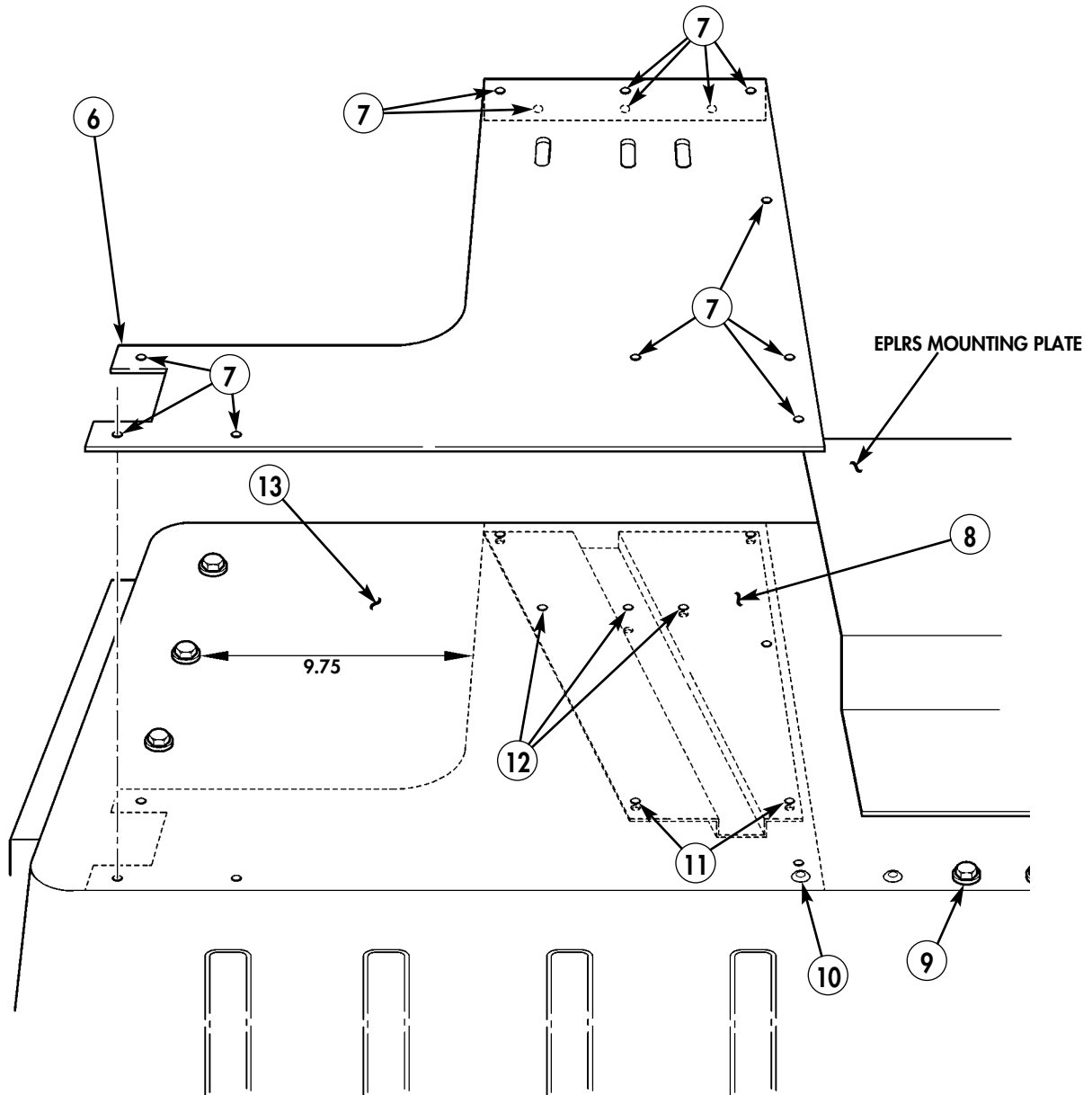

**6. ANTENNA PLATE - A3104004-1 - QTY. 1**

*Figure 5-64.*

**NOTE**

Enlarge hole on antenna mount assembly to accommodate 7/16-in. bolts.

- 26-6.** Install antenna mount assembly (16), upper antenna plate (6), and lower antenna plate (22) on left rear wheelhouse (13) with eleven capscrews (19), twenty-two washers (18), eleven lockwashers (20), and nuts (21).
- 26-7.** Secure antenna mount assembly (16), upper antenna plate (6), and lower antenna plate (22) to left rear wheelhouse (13) with two capscrews (14), four washers (15), two lockwashers (23), and nuts (24).
- 26-8.** Secure antenna mount assembly (16), upper antenna plate (6), and lower antenna plate (22) to left rear wheelhouse (13) with two capscrews (17), four washers (18), two lockwashers (20), and nuts (21).
- 26-9.** Secure antenna mount assembly (16), upper antenna plate (6), and lower antenna plate (22) to left rear wheelhouse (13) with capscrew (25), two washers (15), lockwasher (23), and nut (24).

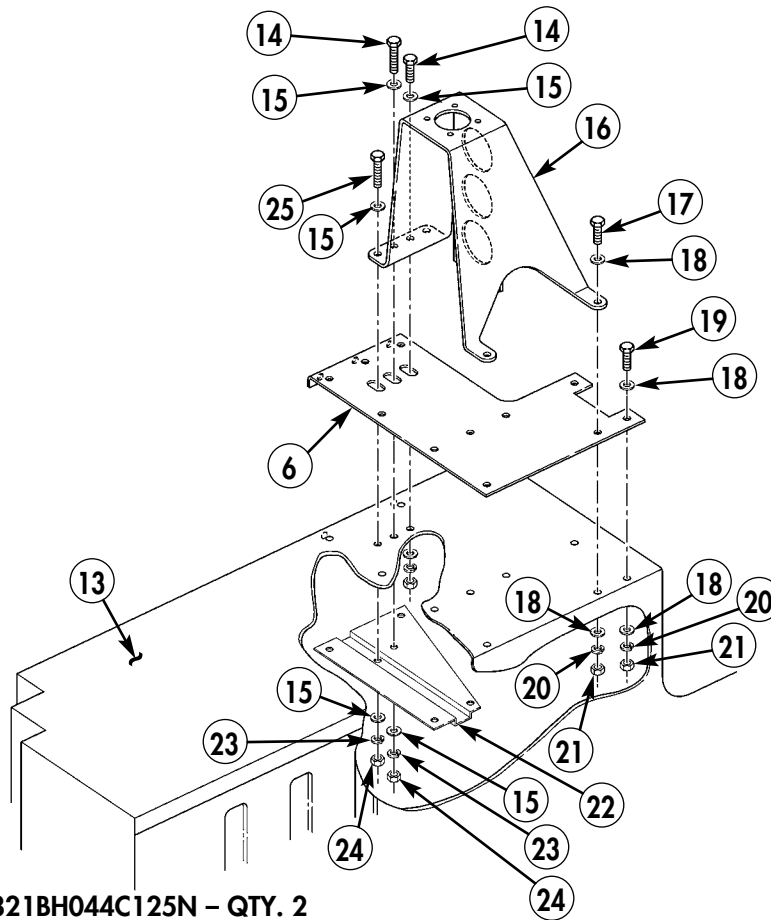

- 14. CAPSCREW - B1821BH044C125N - QTY. 2
- 15. WASHER - 2436163 - QTY. 6
- 17. CAPSCREW - B1821BH025C150N - QTY. 2
- 18. WASHER - 2436161 - QTY. 26
- 19. CAPSCREW - B1821BH025C100N - QTY. 11
- 20. LOCKWASHER - MS35338-44 - QTY. 13
- 21. NUT - 9419143 - QTY. 13
- 22. ANTENNA PLATE - A3157619 - QTY. 1
- 23. LOCKWASHER - 120382 - QTY. 3
- 24. NUT - 13218E0320-293 - QTY. 3
- 25. CAPSCREW - B1821BH044C150N - QTY. 1

Figure 5-65.



**NOTE**

Perform step 26-10 only if not installing cargo soft-top enclosure; otherwise, start with step 26-11.

- 26-10. Install antenna (27) on antenna mount assembly (16) with NTDR bracket (29), four capscrews (26), two gaskets (28), eight lockwashers (34), and four nuts (33).

**NOTE**

Perform steps 26-11 through 26-13 only when installing cargo soft-top enclosure.

- 26-11. Install cargo soft-top enclosure (35). (Refer to TM 9-2320-280-10.)

**NOTE**

Ensure all slack has been taken out of cargo soft-top enclosure, and that cargo soft-top enclosure has been properly installed.

- 26-12. Using antenna (27) as template, locate, mark, and drill four 0.375-in. holes (36) and cut "X" (37) in cargo soft-top enclosure (35).
- 26-13. Install antenna (27) on antenna mount assembly (16) and cargo soft-top enclosure (35) with NTDR bracket (29), four capscrews (26), gaskets (28), eight lockwashers (34), and four nuts (33), ensuring that ground strap (32) is inserted through cut hole (37).
- 26-14. Install ground strap (32) on antenna mount assembly (16) with screw (31), three lockwashers (30), and nut (21).
- 26-15. Tighten nuts (21) and (33).
- 26-16. Install NTDR antenna (38) on NTDR bracket (29) with adapter (39), grommet (40), washer (41), and nut (42).

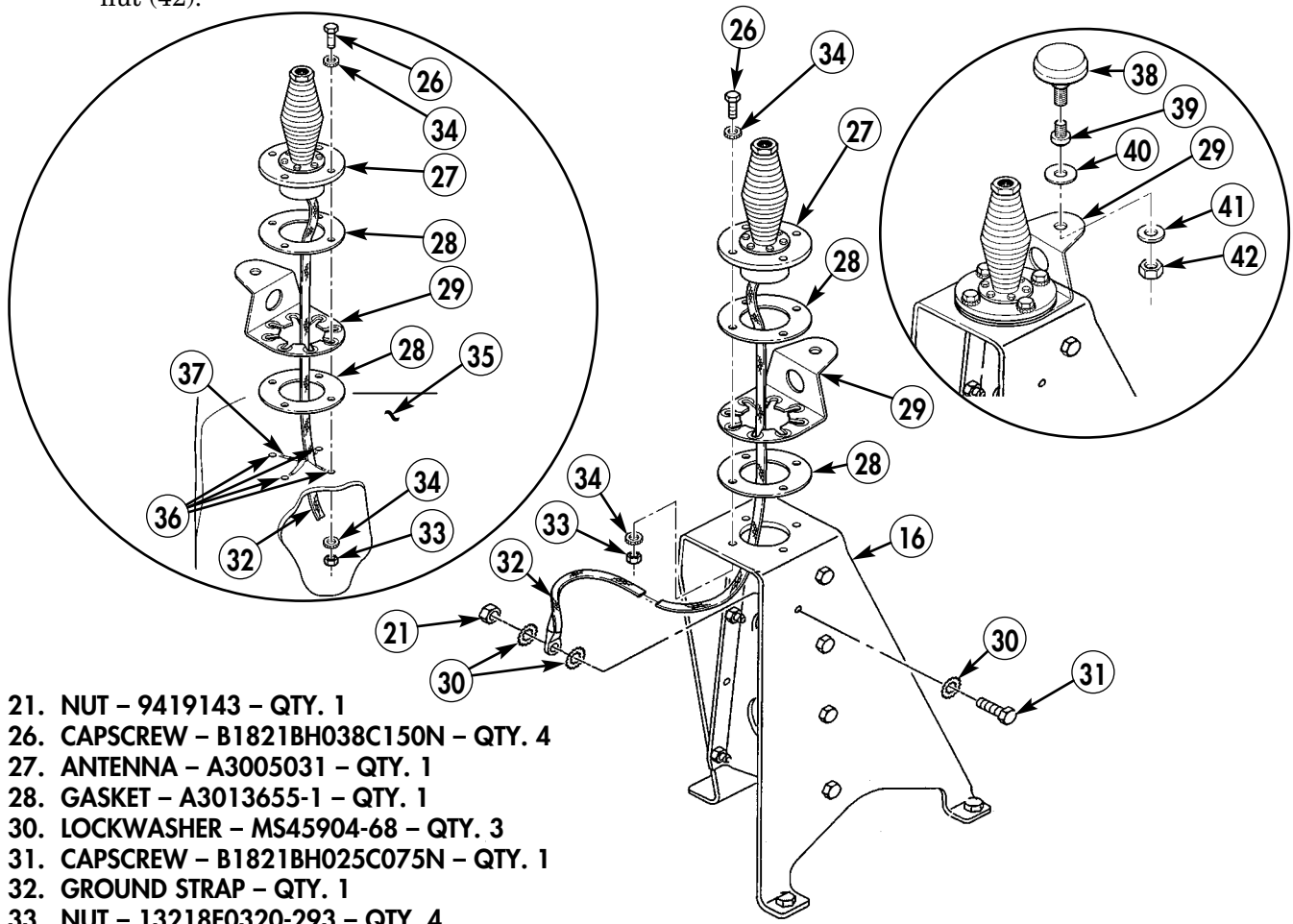

- 21. NUT - 9419143 - QTY. 1
- 26. CAPSCREW - B1821BH038C150N - QTY. 4
- 27. ANTENNA - A3005031 - QTY. 1
- 28. GASKET - A3013655-1 - QTY. 1
- 30. LOCKWASHER - MS45904-68 - QTY. 3
- 31. CAPSCREW - B1821BH025C075N - QTY. 1
- 32. GROUND STRAP - QTY. 1
- 33. NUT - 13218E0320-293 - QTY. 4
- 34. LOCKWASHER - MS45904-76 - QTY. 8

Figure 5-66.

**Section XXVII. POWER ENTRY BOX INSTALLATION**

- 27-1.** Locate, mark, and drill one 0.188-in. diameter hole (4) in right wheelhouse (5).
- 27-2.** Using power entry box (7) as template, locate, mark, and drill three 0.188-in. diameter holes (3) in right wheelhouse (5).
- 27-3.** Install power entry box (7) on right wheelhouse (5) with four capscrews (1), eight washers (2), and four locknuts (6).

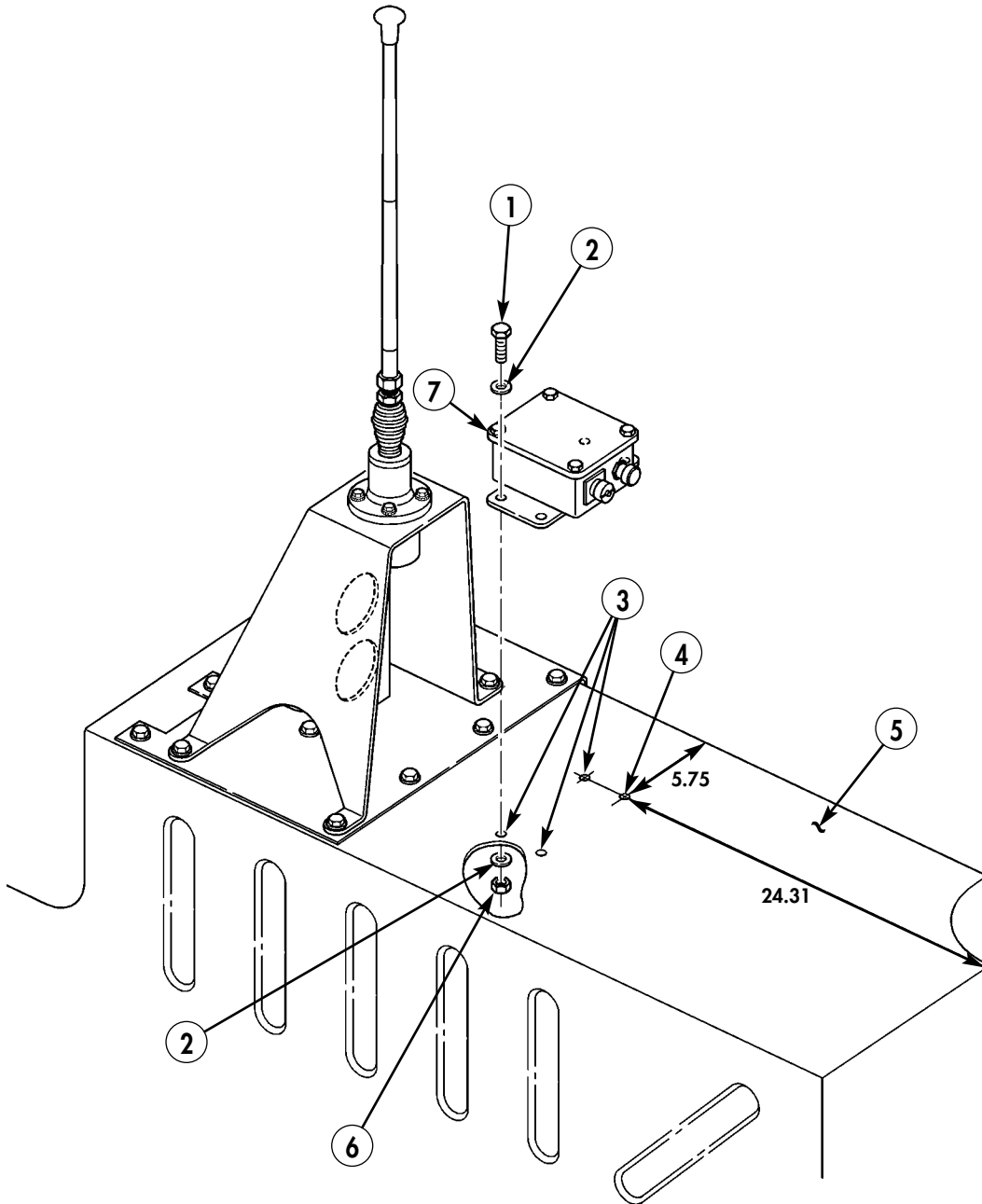

- 1. SCREW – MS35207-265 – QTY. 4**
- 2. WASHER – MS27183-8 – QTY. 8**
- 6. NUT – MS35650-302 – QTY. 4**
- 7. POWER ENTRY BOX – 03A0108D – QTY. 1**

*Figure 5-67.*

## Section XXVIII. EPLRS URO (USER READOUT) INSTALLATION

### NOTE

- Cables have been removed for clarity.
- Ensure all mounting holes are on the flat surface of cargo floor raised ribs.
- SINCGARS model AN/VRC-92F shown.

- 28-1.** Locate, mark, and drill four 0.147-in. holes (5) on tunnel (4) in between integrated rack (2) and lower shelf of multi-net rack (3).
- 28-2.** Install URO bracket (7) on tunnel (4) with four self-tapping screws (1) and spacers (6).

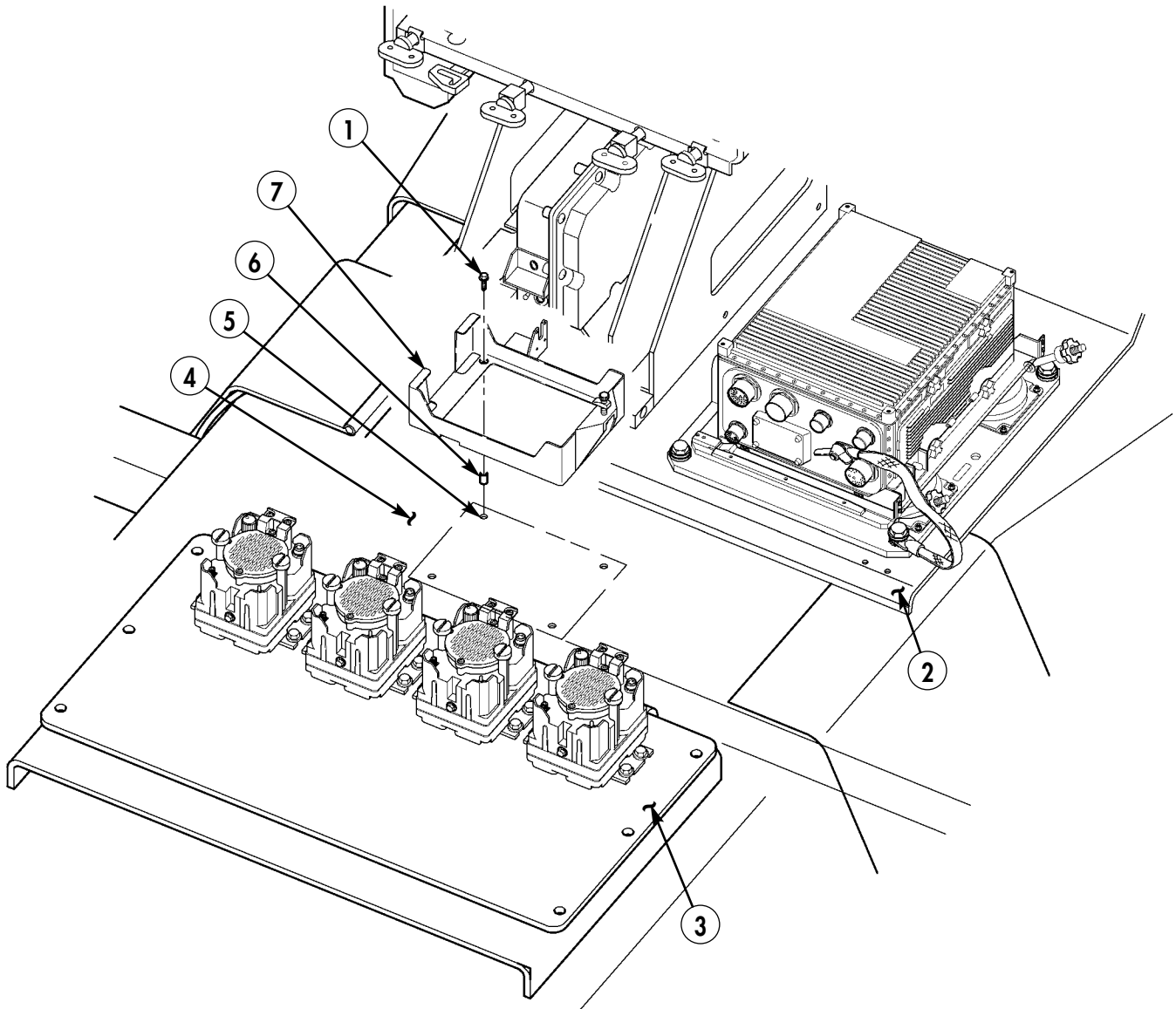

1. SELF-TAPPING SCREW - 9426634 - QTY. 4  
 6. SPACER - 92510A318 - QTY. 4  
 7. URO (USER READOUT) BRACKET - A3006206 - QTY. 1

Figure 5-68.

## Section XXIX. LOUDSPEAKER INSTALLATION ON WINDSHIELD FRAME

### NOTE

- Perform steps 29-1 through 29-7 for vehicles with vertical wiper motor only.
- If sun visor kit has been installed, remove driver's side visor. (Refer to TM 9-2320-280-20.)
- Relocate all caution labels as necessary.

- 29-1.** Using mounting plate (4) as template, center on right side of windshield frame (9) between wiper motor mounting plate (8) and footman loop (6). Mark and drill four 0.390-in. diameter holes (7) in windshield frame (9).
- 29-2.** Install four inserts (5) in windshield frame (9).
- 29-3.** Install mounting plate (4) with four capscrews (1), lockwashers (2), and washers (3).

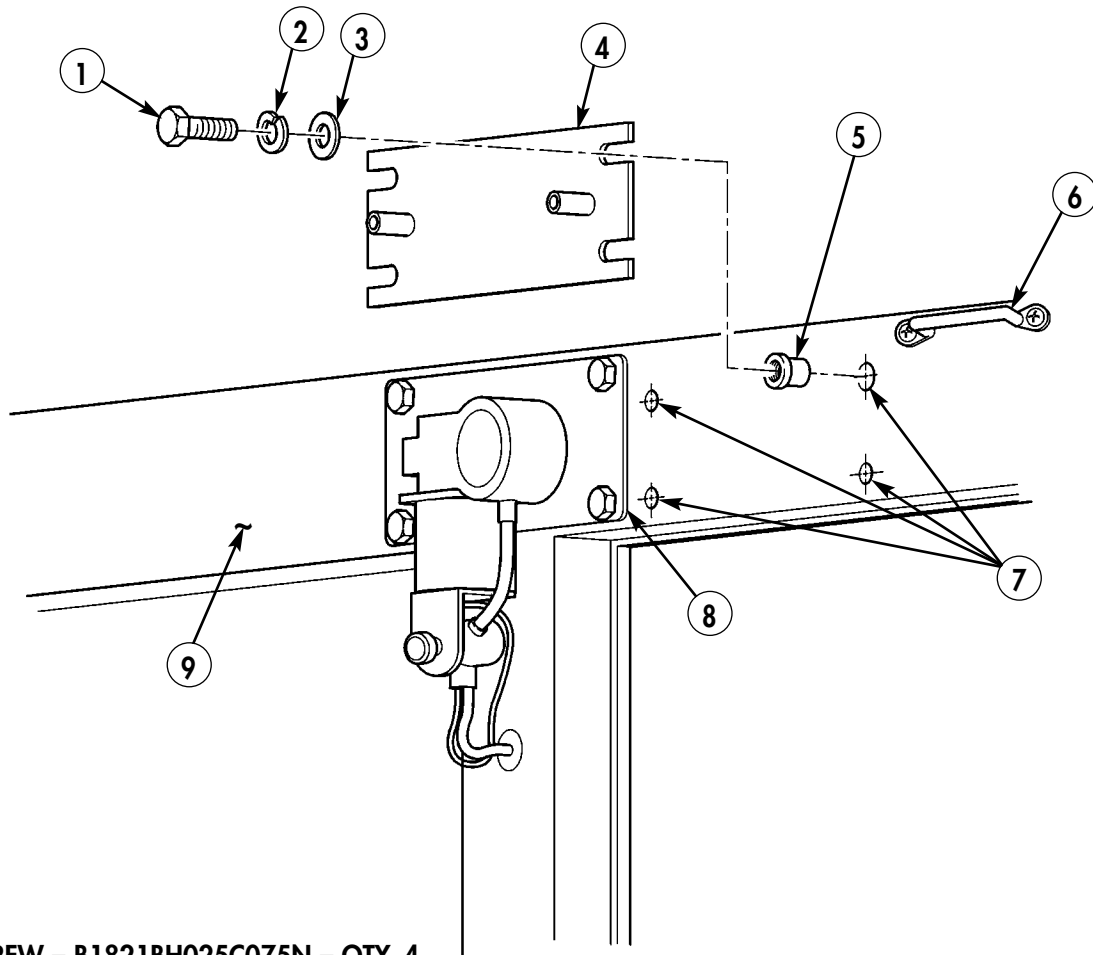

1. CAPSCREW - B1821BH025C075N - QTY. 4
2. LOCKWASHER -MS35338-44 - QTY. 4
3. WASHER - 2436161 - QTY. 4
4. MOUNTING PLATE - A3014550-1 - QTY. 1
5. INSERT - 12446871-2 - QTY. 4

Figure 5-69.

- 29-4. Using mounting plate (4) as template, center on left side of windshield frame (9) between wiper mounting plate (8) and footman loop (11). Mark and drill four 0.390-in. diameter holes (10) in windshield frame (9).
- 29-5. Install four inserts (5) in windshield frame (9).
- 29-6. Install mounting plate (4) with four capscrews (1), lockwashers (2), and washers (3).

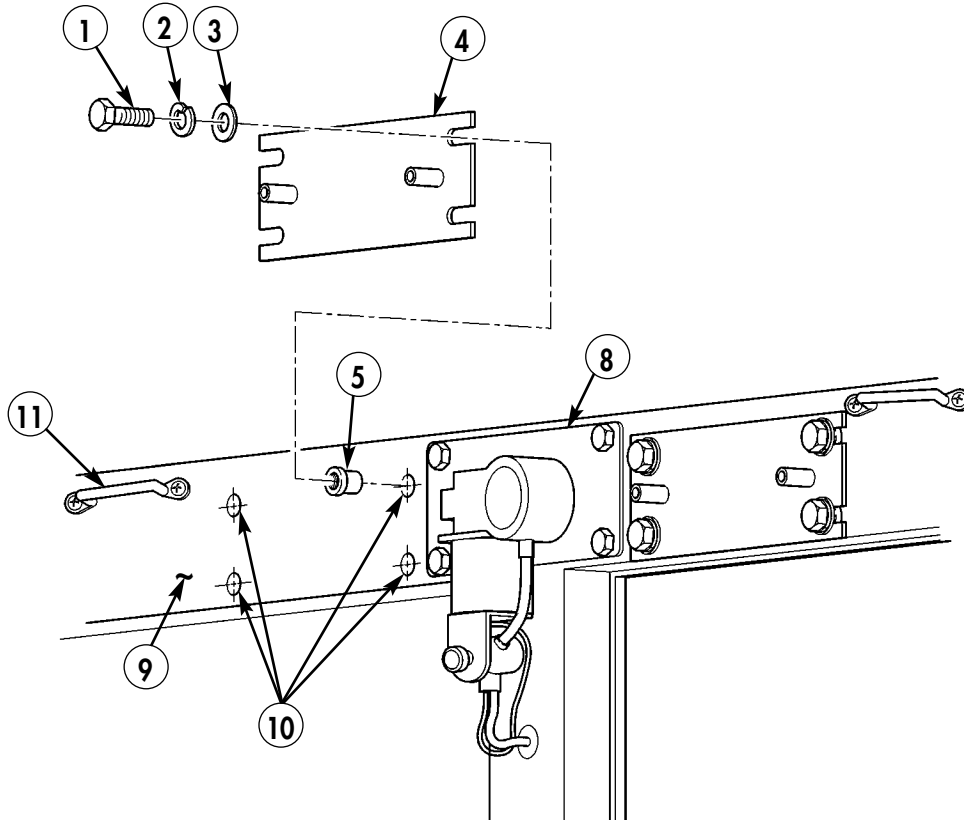
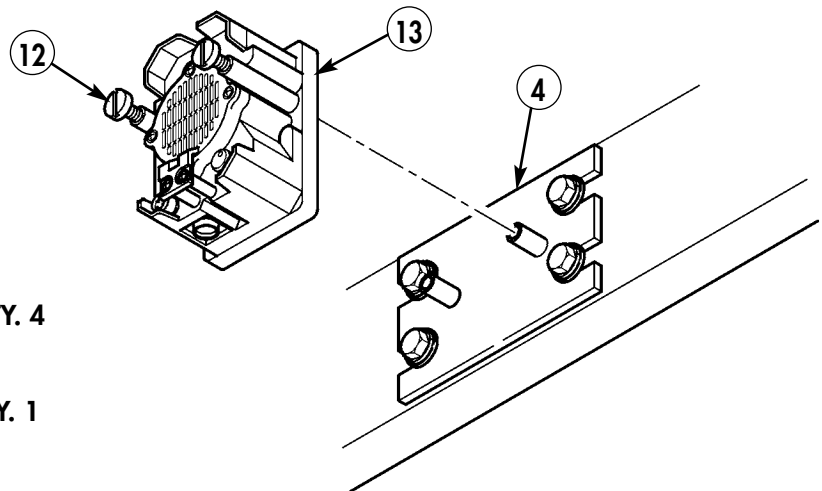

Figure 5-70.

- 29-7. Attach loudspeaker (13) to mounting plate (4) with two externally-relieved body screws (12). Repeat for opposite side.



- 1. CAPSCREW - B1821BH025C075N - QTY. 4
- 2. LOCKWASHER -MS35338-44 - QTY. 4
- 3. WASHER - 2436161 - QTY. 4
- 4. MOUNTING PLATE - A3014550-1 - QTY. 1
- 5. INSERT - 12446871-2 - QTY. 4
- 13. LOUDSPEAKER -A3014065-1 -QTY. 2

Figure 5-71.

**NOTE**

Perform steps 29-8 through 29-14 for vehicles with horizontal wiper motor only.

- 29-8. Using mounting plate (4) as template, center on right side of windshield frame (9) between wiper motor mounting plate (8) and footman loop (6). Mark and drill four 0.390-in. diameter holes (7) in windshield frame (9).
- 29-9. Install four inserts (5) in windshield frame (9).
- 29-10. Install mounting plate (4) with four capscrews (1), lockwashers (2), and washers (3).

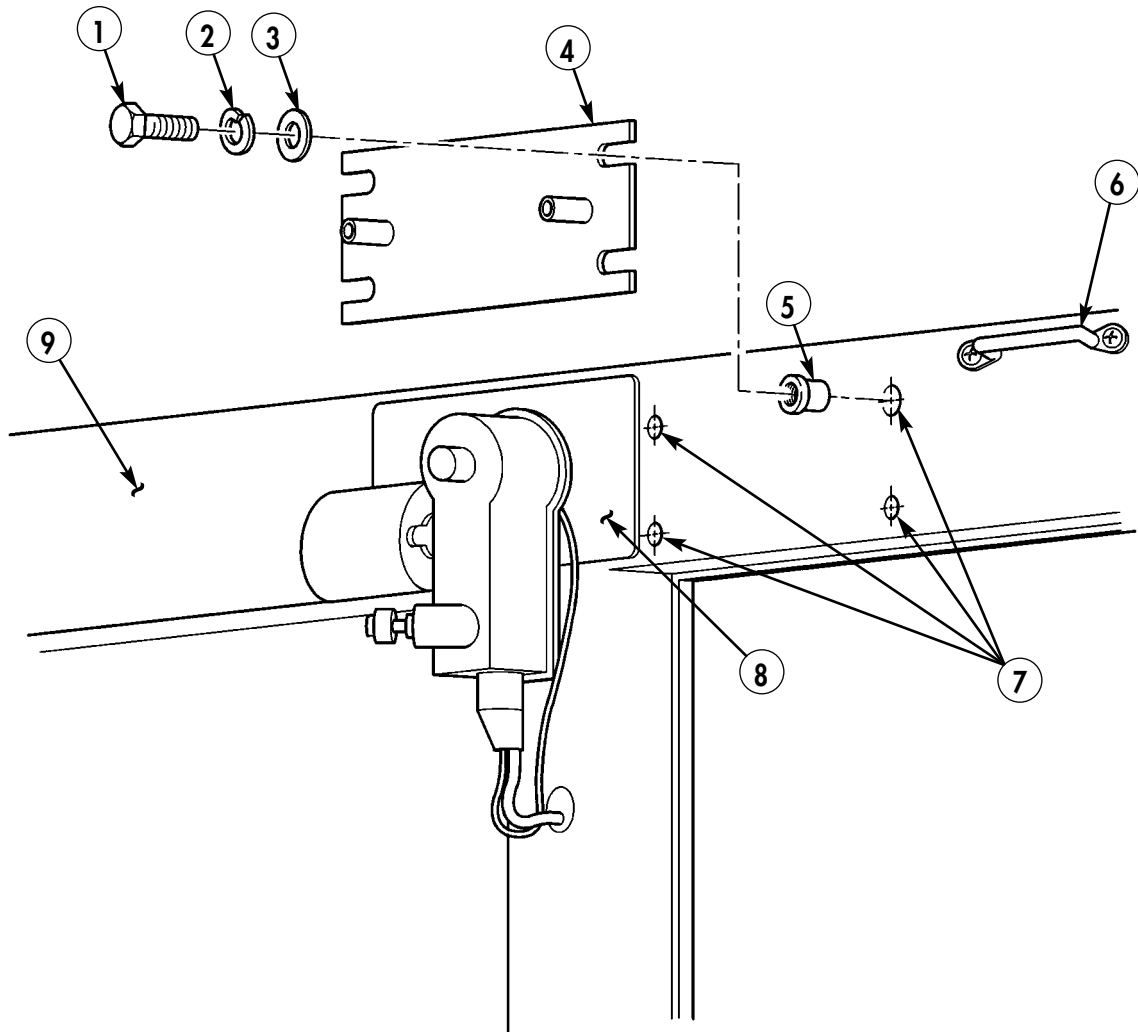

- 1. CAPSCREW - B1821BH025C075N - QTY. 4
- 2. LOCKWASHER -MS35338-44 - QTY. 4
- 3. WASHER - 2436161 - QTY. 4
- 4. MOUNTING PLATE - A3014550-1 - QTY. 1
- 5. INSERT - 12446871-2 - QTY. 4

Figure 5-72.

- 29-11. Using mounting plate (4) as template, center on left side of windshield frame (9) between access hole (15) and footman loop (11). Mark and drill four 0.390-in. holes (14) in windshield frame (9).
- 29-12. Install four inserts (5) in windshield frame (9).
- 29-13. Install mounting plate (4) with four capscrews (1), lockwashers (2), and washers (3).

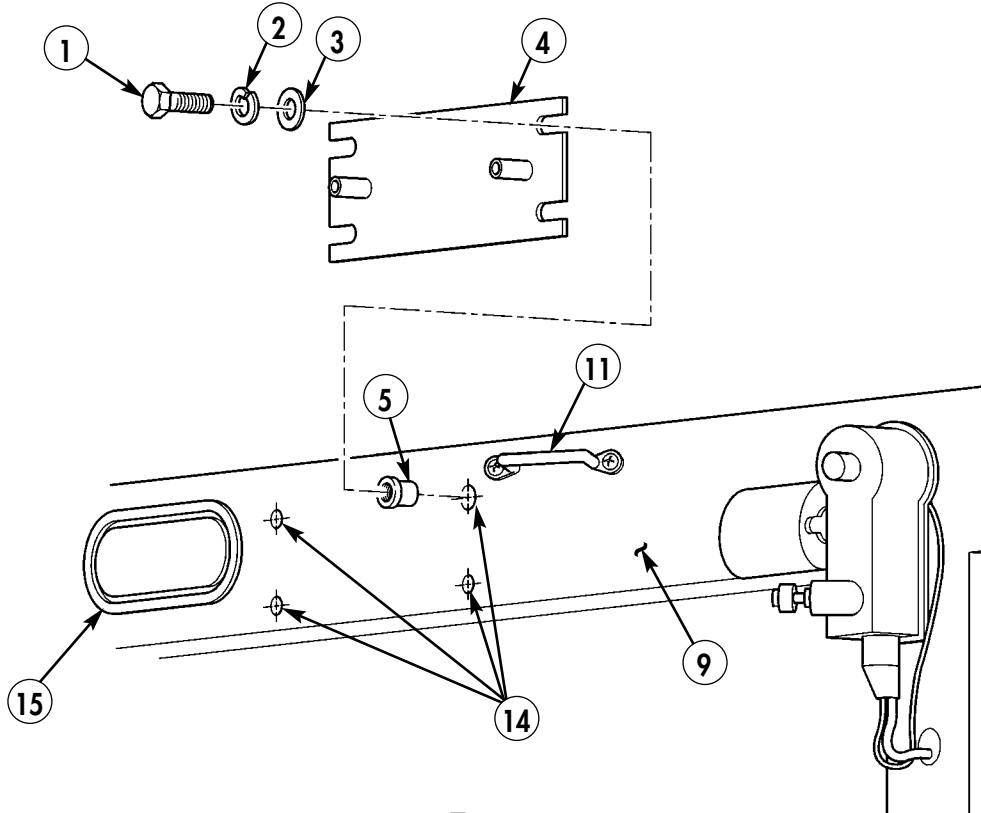
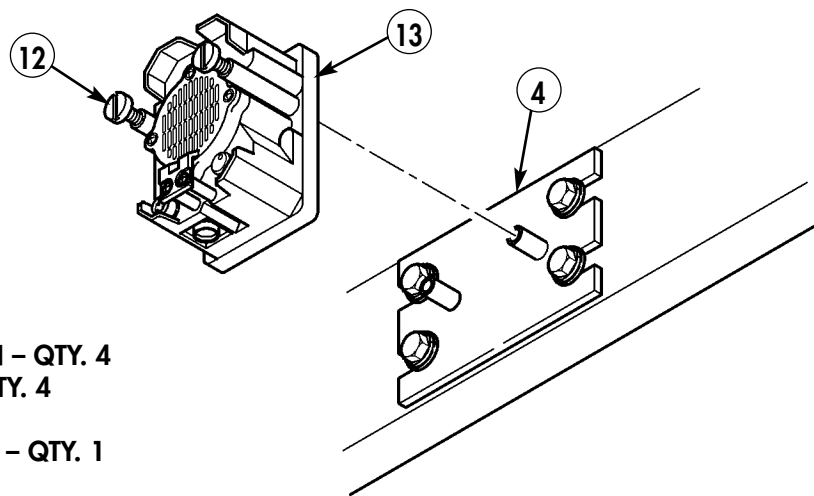

Figure 5-73.

- 29-14. Attach loudspeaker (13) to mounting plate (4) with two externally-relieved body screws (12). Repeat for opposite side.



- 1. CAPSCREW - B1821BH025C075N - QTY. 4
- 2. LOCKWASHER -MS35338-44 - QTY. 4
- 3. WASHER - 2436161 - QTY. 4
- 4. MOUNTING PLATE - A3014550-1 - QTY. 1
- 5. INSERT - 12446871-2 - QTY. 4
- 13. LOUDSPEAKER -A3014065-1 -QTY. 2

Figure 5-74.

### Section XXX. QEAM MOUNTING: ANTENNAS AND BRACKETS

**30-1.** Install four clamp subassemblies (5) to QEAM rack (4) with four capscrews (1), washers (2), and lockwashers (3).

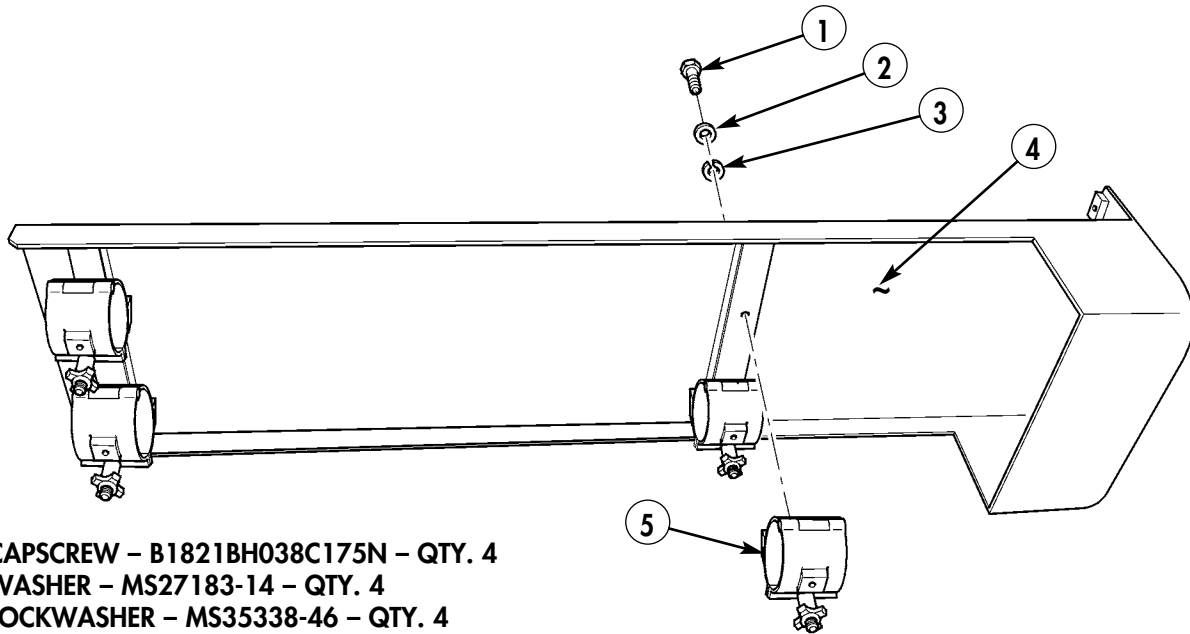

- 1. CAPSCREW – B1821BH038C175N – QTY. 4
- 2. WASHER – MS27183-14 – QTY. 4
- 3. LOCKWASHER – MS35338-46 – QTY. 4
- 4. RACK, QEAM – PKMM 000-006 – QTY. 1
- 5. CLAMP SUBASSEMBLY – 04A0010D – QTY. 4

*Figure 5-75.*



- 30-2.** Remove windshield wiper from right-side windshield frame. (Refer to TM 9-2320-280-20-3.)
- 30-3.** Position cutout of QEAM rack (4) centered on windshield wiper pivot (8).
- 30-4.** Using QEAM rack (4) as template, locate, mark, and drill four 0.250-in. diameter holes in right-side windshield frame (6). Remove QEAM rack (4).
- 30-5.** Enlarge four holes drilled in step 30-4 to 0.391-in. diameter.
- 30-6.** Install four inserts (11) in windshield frame (6).
- 30-7.** Install QEAM rack (4) on windshield frame (6) with four capscrews (7), washers (9), lockwashers (10), and inserts (11).
- 30-8.** Install windshield wiper. (Refer to TM 9-2320-280-20-3.)

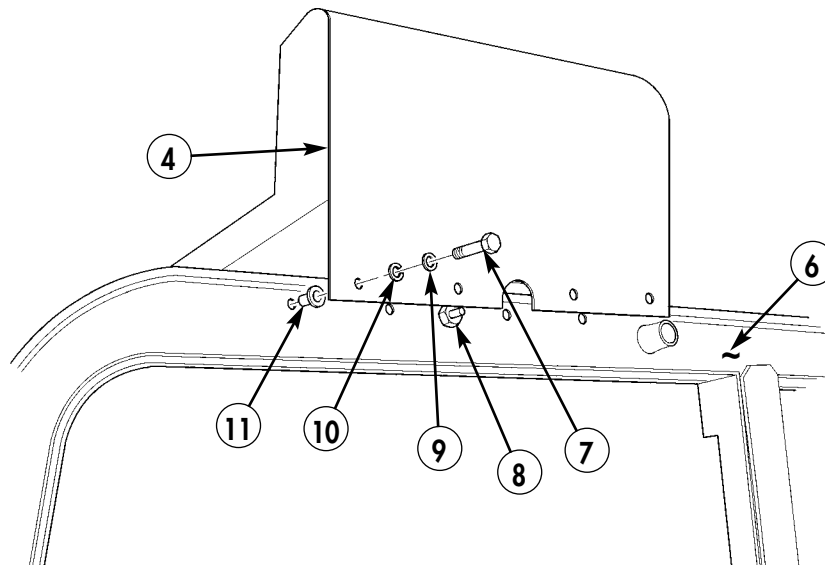

- 7. CAPSCREW – B1821BH025C150N – QTY. 4**
- 9. WASHER – MS27183-10 – QTY. 4**
- 10. LOCKWASHER – MS35338-44 – QTY. 4**
- 11. INSERT – 12446871-2 – QTY. 4**

*Figure 5-76.*

30-9. Scribe line around C-beam (13) to locate hole position (12) on underside of C-beam (13).

**NOTE**

- C-beam is angled and bolt length will be lost if hole is drilled too far forward.
- Center holes vertically on C-beam.

30-10. Drill two 0.343-in. diameter holes (12) through C-beam (13).

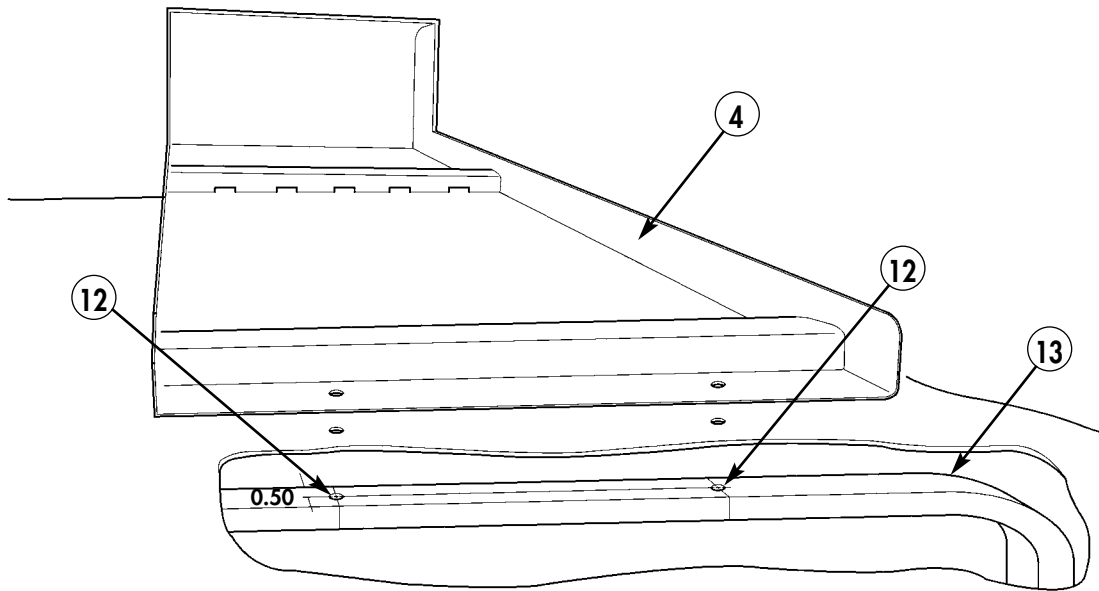

Figure 5-77.

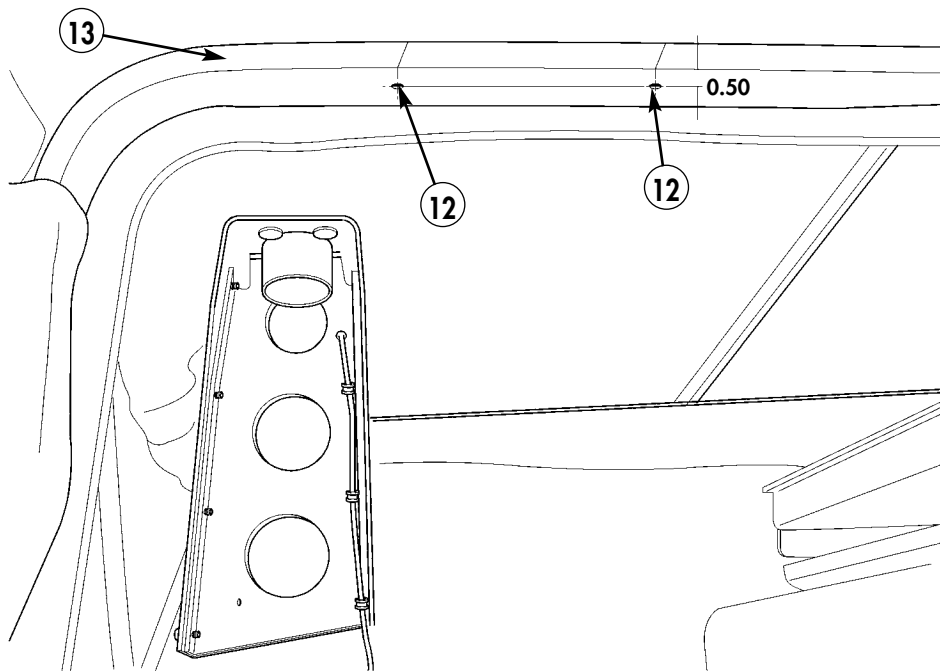
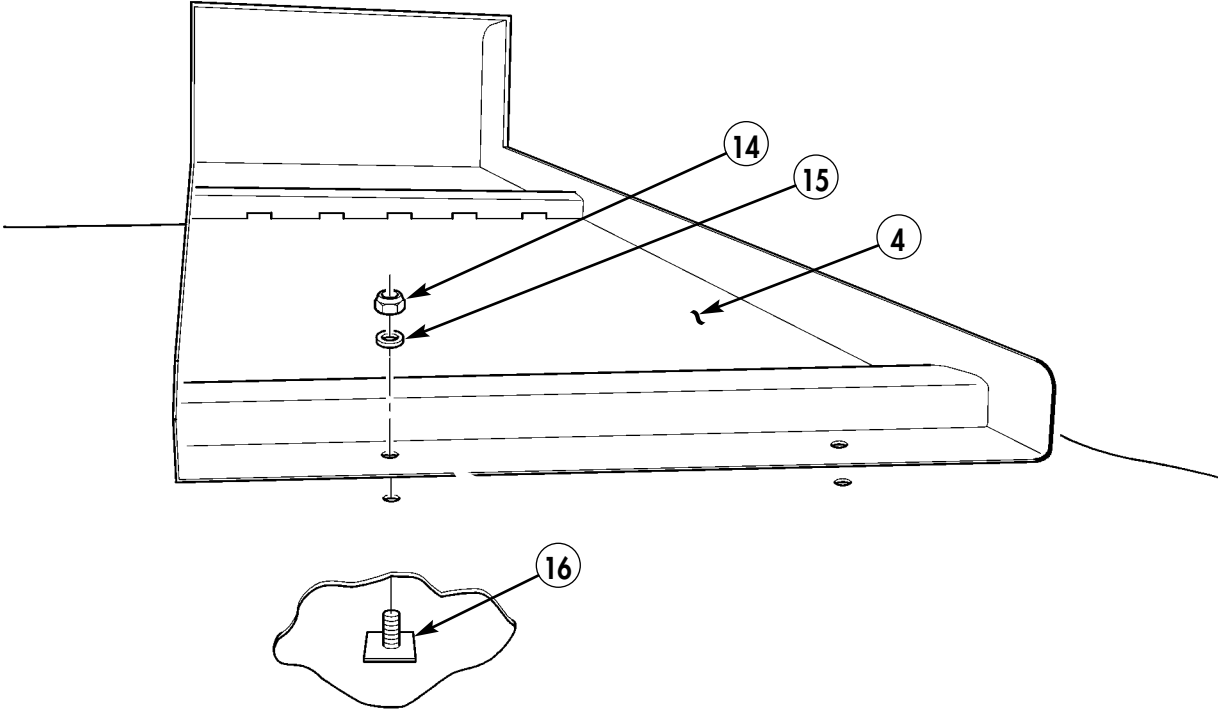

Figure 5-78.

30-11. Secure QEAM rack (4) to C-beam with two backing plates (16), washer (15), and locknuts (14).



- 14. LOCKNUT - MS17829-5C - QTY. 2
- 15. WASHER - MS27183-12 - QTY. 2
- 16. BACKING PLATE - 03A0102D - QTY. 2

Figure 5-79.

**NOTE**

Use folding step as a template to correctly space holes.

**30-12.** Locate, mark, and drill two 0.328-in. diameter holes (18) in body of vehicle (17).

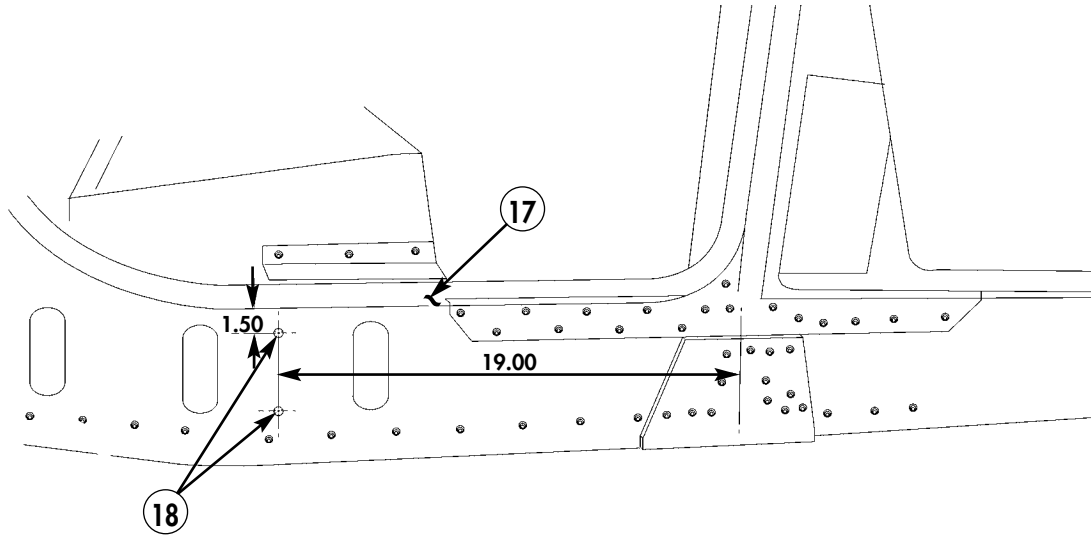

Figure 5-80.

**30-13.** Locate, mark, and drill two 0.328-in. diameter holes (19) in body of vehicle (17).

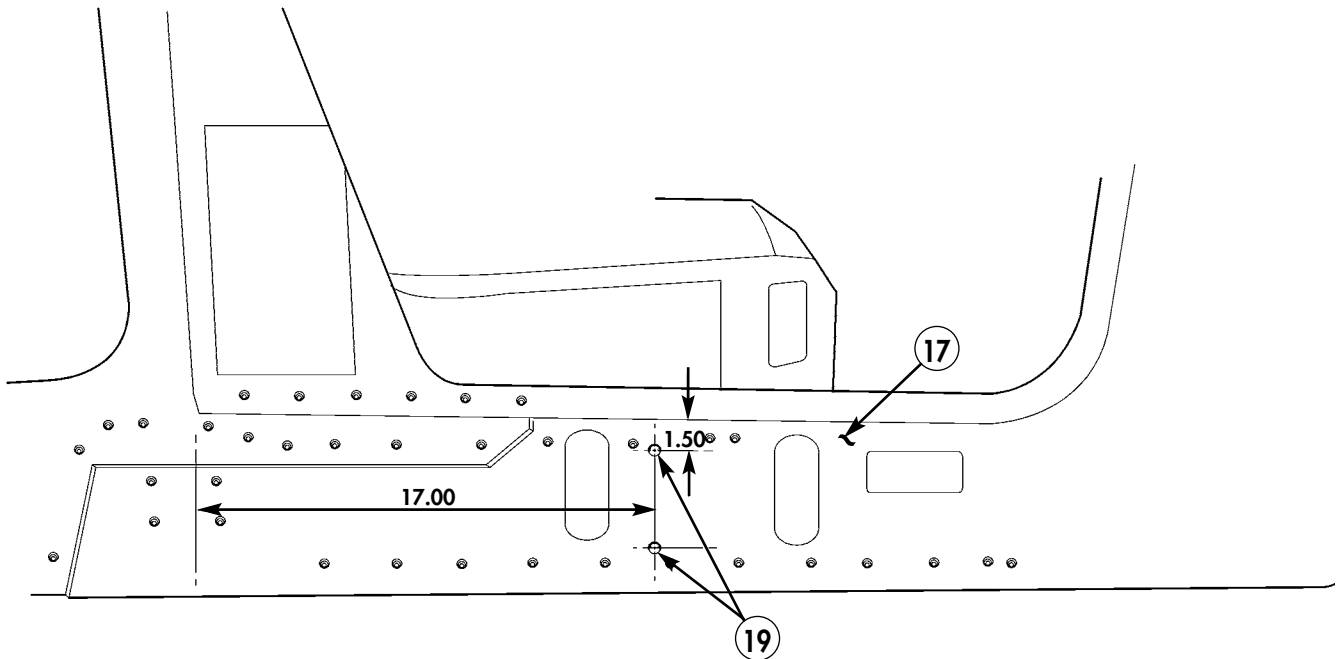
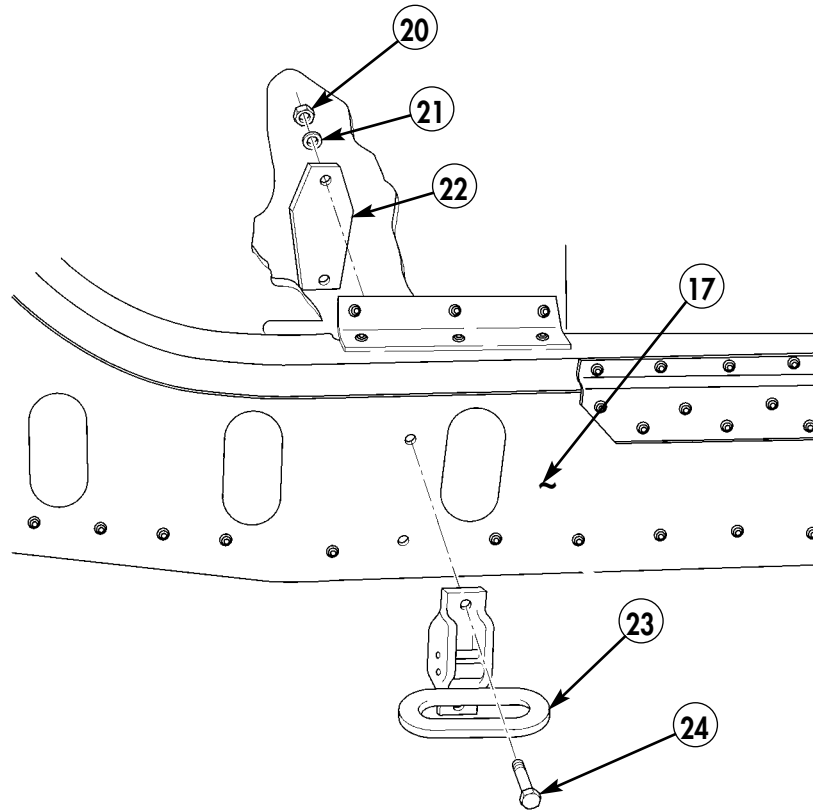

Figure 5-81.

**NOTE**

Rear folding step installation is shown. Front folding step is mounted the same way.

- 30-14.** Install folding step (23) on body of vehicle (17) with two screws (24), backing plate (22), two washers (21), and locknuts (20).



20. LOCKNUT - MS17829-5C - QTY. 2  
 21. LOCKWASHER - MS45904-72 - QTY. 2  
 22. BACKING PLATE - 03A0101D - QTY. 2  
 23. FOLDING STEP - 2797AZN - QTY. 2  
 24. CAPSCREW - B1821BH031C125N - QTY. 2

*Figure 5-82.*

### Section XXXI. DAGR BRACKET INSTALLATION

- 31-1. Install DAGR bracket (11) on integrated rack (1) with three screws (12) and lockwashers (13).
- 31-2. Locate, mark, and drill one 0.201-in. diameter hole (10) in right-side engine tunnel (9).
- 31-3. Remove paint from vicinity of hole (4) on integrated rack (1) and hole (10) on right-side engine tunnel (9). Apply anti-seize compound as required.
- 31-4. Fabricate ground strap (5) from 8.00-in. length of braided wire and two terminal lugs.
- 31-5. Install ground strap (5) on integrated rack (1) with capscrew (6), three lockwashers (2), and nut (3).
- 31-6. Install ground strap (5) on right-side engine tunnel (9) with self-tapping screw (8) and two lockwashers (7).

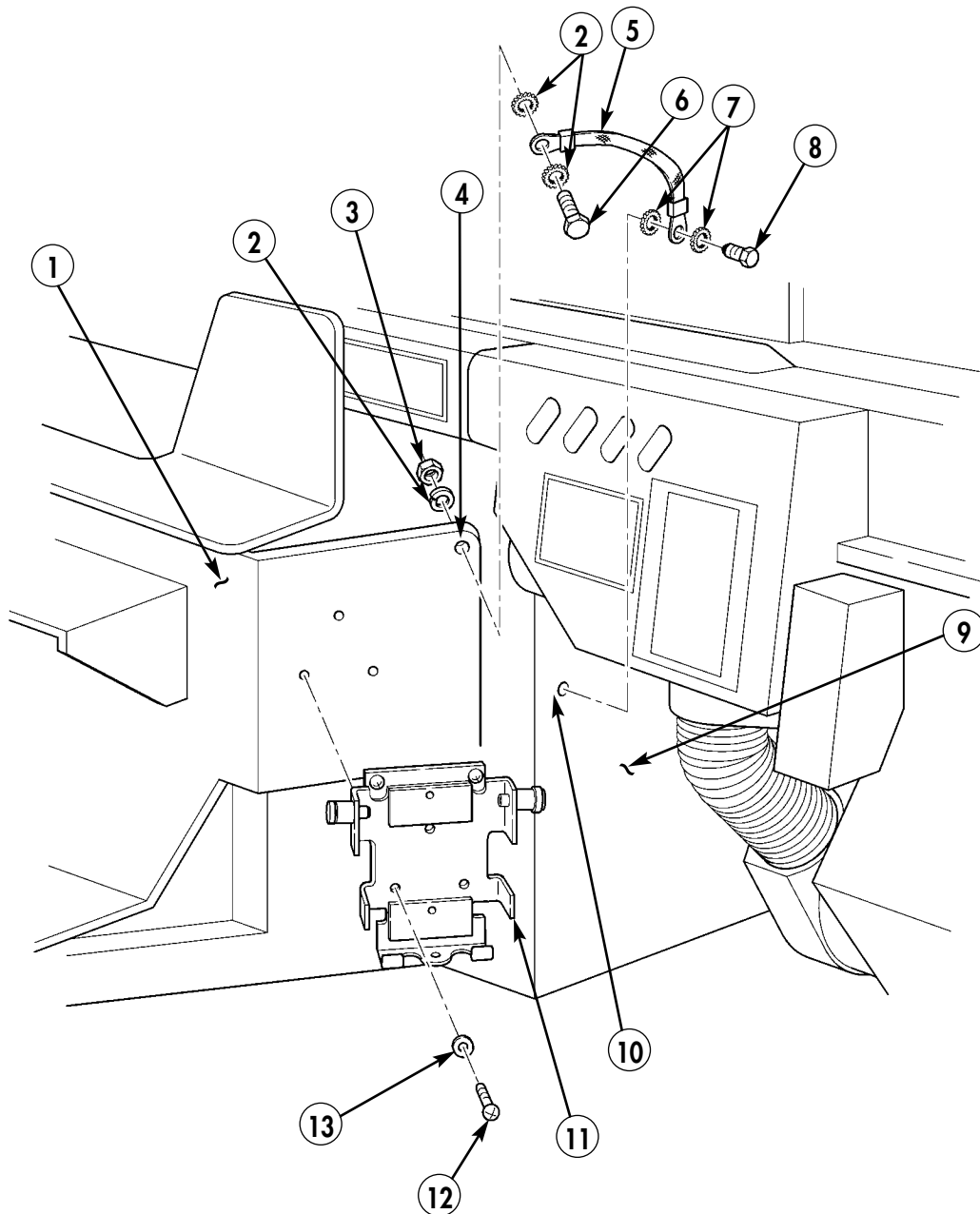
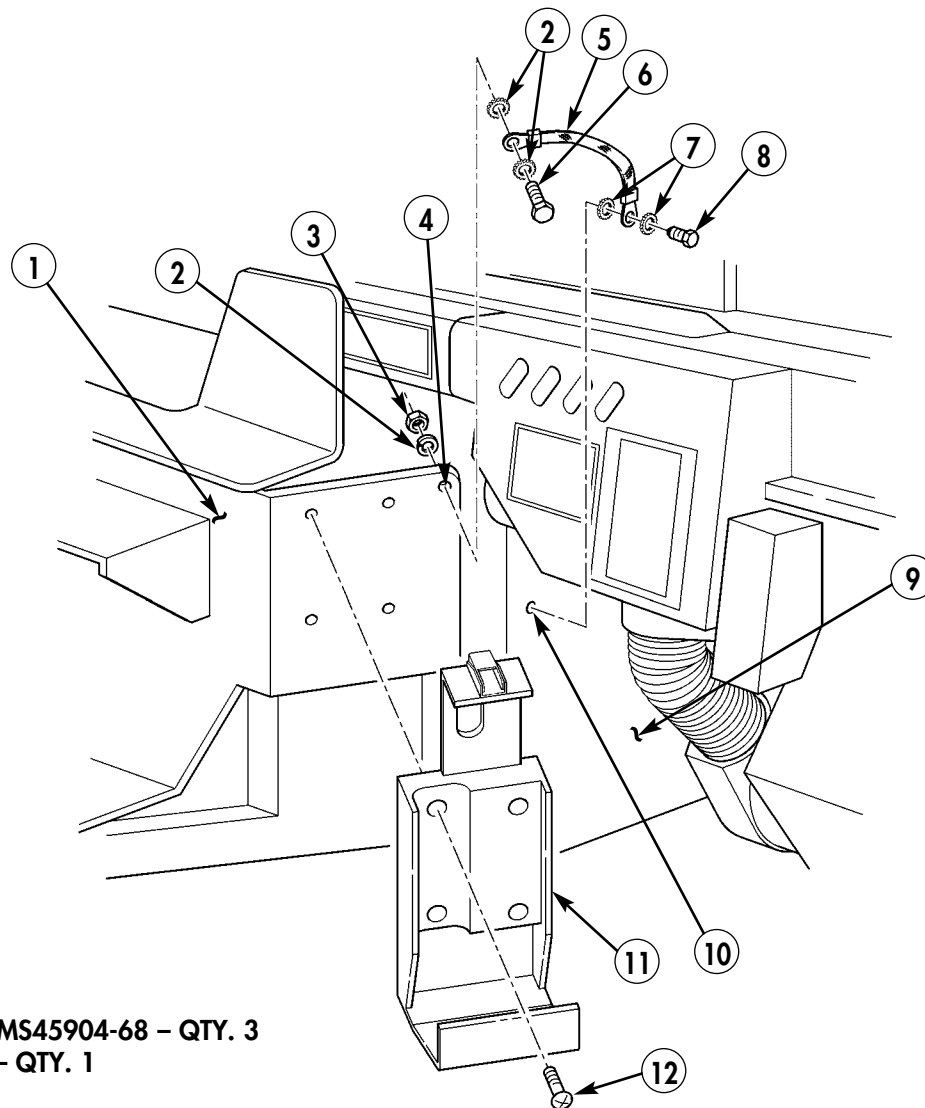

Figure 5-83.

### Section XXXII. PLGR BRACKET INSTALLATION

- 32-1. Install PLGR bracket (11) on integrated rack (1) with four screws (12).
- 32-2. Locate, mark, and drill one 0.201-in. diameter hole (10) in right-side engine tunnel (9).
- 32-3. Remove paint from vicinity of hole (4) on integrated rack (1) and hole (10) on right-side engine tunnel (9). Apply anti-seize compound as required.
- 32-4. Fabricate ground strap (5) from 8.00-in. length of braided wire and two terminal lugs.
- 32-5. Install ground strap (5) on integrated rack (1) with capscrew (6), three lockwashers (2), and nut (3).
- 32-6. Install ground strap (5) on right-side engine tunnel (9) with self-tapping screw (8) and two lockwashers (7).



2. LOCKWASHER – MS45904-68 – QTY. 3
3. NUT – 9419143 – QTY. 1
5. GROUND STRAP
  - BRAIDED WIRE – AA59569F30T0375 – QTY. A/R
  - TERMINAL LUG – MS20659-129 – QTY. 2
6. CAPSCREW – B1821BH025C100N – QTY. 1
7. LOCKWASHER – MS35338-43 – QTY. 2
8. SELF-TAPPING SCREW – 9426241 – QTY. 1
11. PLGR BRACKET – 986-0645-001 – QTY. 1
12. SCREW – MS35206-263 – QTY. 4

Figure 5-84.

### Section XXXIII. ANTENNA AND CABLE INSTALLATION (WITHOUT BOLT-ON ARMOR)

#### NOTE

- DAGR shown, PLGR similar.
- Drilled holes on inside and outside of windshield frame should be aligned with each other to allow routing of DAGR cable through windshield frame.
- Relocate all caution labels as necessary.
- Drilled holes on inside and outside of windshield frame should be aligned with each other to allow routing of DAGR cable through windshield frame.
- Use left side plug as reference point to measure hole for antenna cable.

**33-1.** Locate, mark, and drill 0.375-in. diameter hole (1) in outer right-side windshield frame (2).

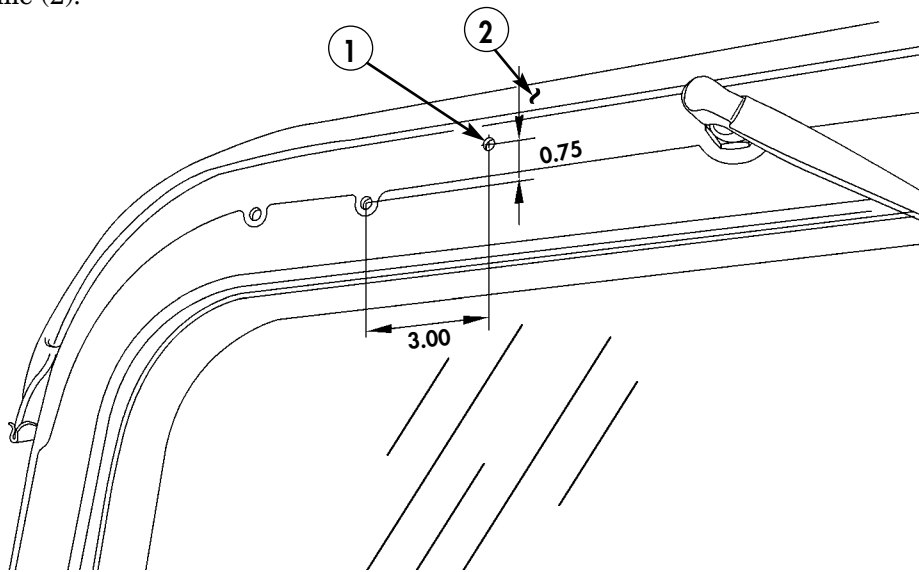

Figure 5-85.

**33-2.** Locate, mark, and drill 0.375-in. diameter hole (3) in inner right-side windshield frame (4).

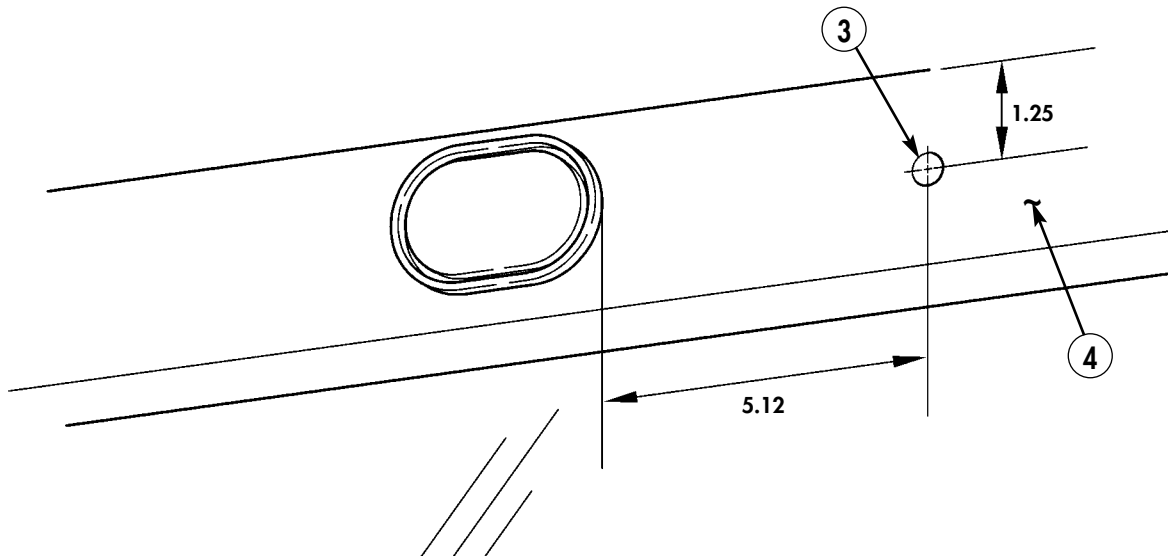

Figure 5-86.



- 33-3. Pull DAGR antenna cable (6) through hole (17) in left-side outer windshield frame (2). Split one side of grommet (16). Place grommet (16) on cable (6) and insert grommet (16) in hole (17) in left-side outer windshield frame (2).
- 33-4. Using DAGR antenna mount (7) as a template, locate, mark, and drill two 0.391-in. diameter holes (18) in QEAM rack (12).
- 33-5. Install DAGR antenna (5) to DAGR mount (7) with capscrew (23) and washer (24).
- 33-6. Install DAGR mount to QEAM rack with two capscrews (11), washers (10), spacers (13), lockwashers (19), and nuts (20).
- 33-7. Route antenna cable (6) up through DAGR antenna mount (7).
- 33-8. Attach DAGR antenna cable (6) to DAGR antenna (5).
- 33-9. Secure DAGR antenna cable (6) to DAGR mount (7) with loop clamp (9), capscrew (21), washer (22), and nut (8).
- 33-10. Secure DAGR antenna cable (6) to QEAM rack (12) with loop clamp (14) and self-tapping screw (15).

- 5. DAGR ANTENNA - N/A - QTY. 1
- 6. DAGR ANTENNA CABLE - 426-0141-050 - QTY. 1
- 8. NUT - TO COME - QTY. 1
- 9. LOOP CLAMP - TO COME - QTY. 1
- 10. WASHER - MS2436161 - QTY. 2
- 11. CAPSCREW - B1821BH025C100N - QTY. 2
- 13. SPACER - N/A - QTY. 1
- 14. LOOP CLAMP - MS21333-98 - QTY. 1
- 15. SELF-TAPPING SCREW - 9421073 - QTY. 1
- 16. GROMMET - MS35489-143 - QTY. 1
- 19. LOCKWASHER - MS35338-48 - QTY. 2
- 20. NUT - 9419143 - QTY. 2
- 21. CAPSCREW - TO COME - QTY. 1
- 22. WASHER - TO COME - QTY. 1
- 23. SCREW - 160035 - QTY. 1
- 24. WASHER - 9417373 - QTY. 1

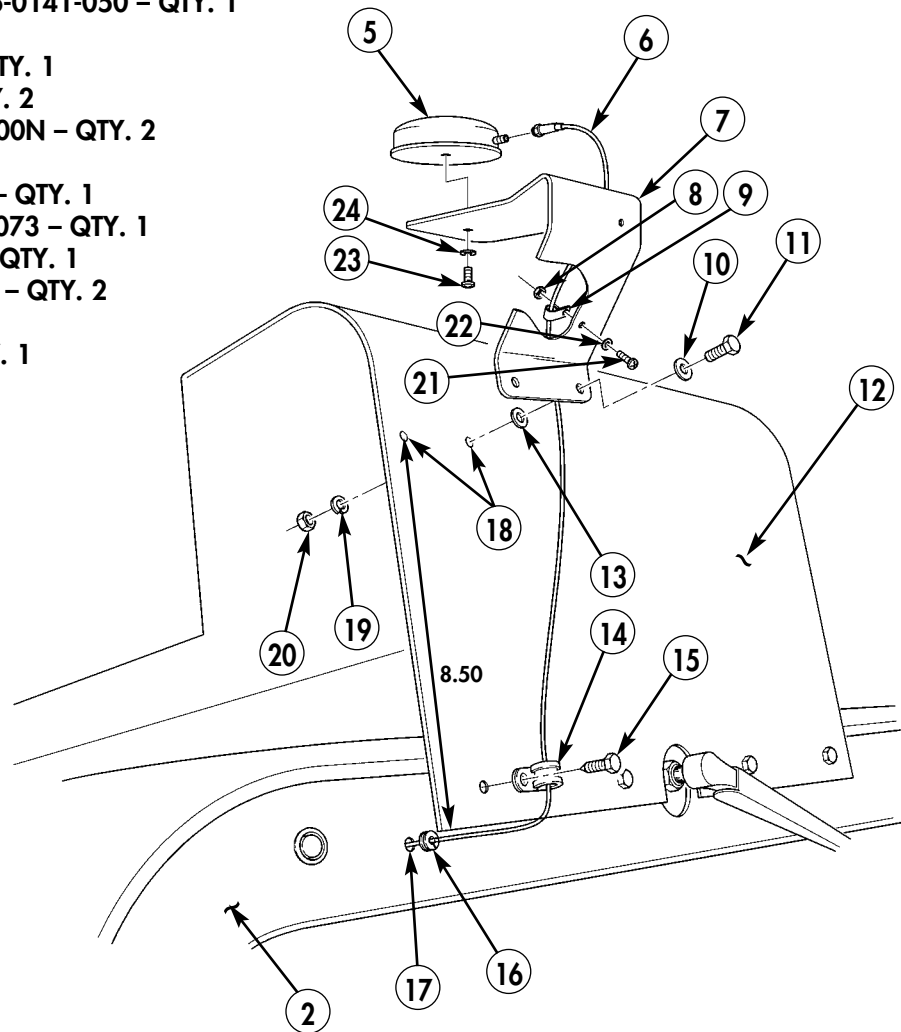

Figure 5-87.

- 33-11. Split one side of grommet (28) and place on DAGR antenna cable (6).
- 33-12. Insert DAGR antenna cable (6) and grommet (28) in hole (3) of inner-right windshield frame (2).

**NOTE**

If sun visor kit has not been installed, perform steps 33-13 and 33-14. If sun visor has been installed, perform step 33-15.

- 33-13. Locate, mark, and drill 0.390-in. diameter hole (29) in windshield frame (2).
- 33-14. Install insert (30) in hole (29) of inner-right windshield frame (2).

**NOTE**

Perform step 33-15 only if sun visor kit has been installed.

- 33-15. Remove capscrew (25) and lockwasher (26).
- 33-16. Route DAGR antenna cable (6) along inner-right windshield frame (2) and secure with loop clamp (27), lockwasher (26), and capscrew (25).

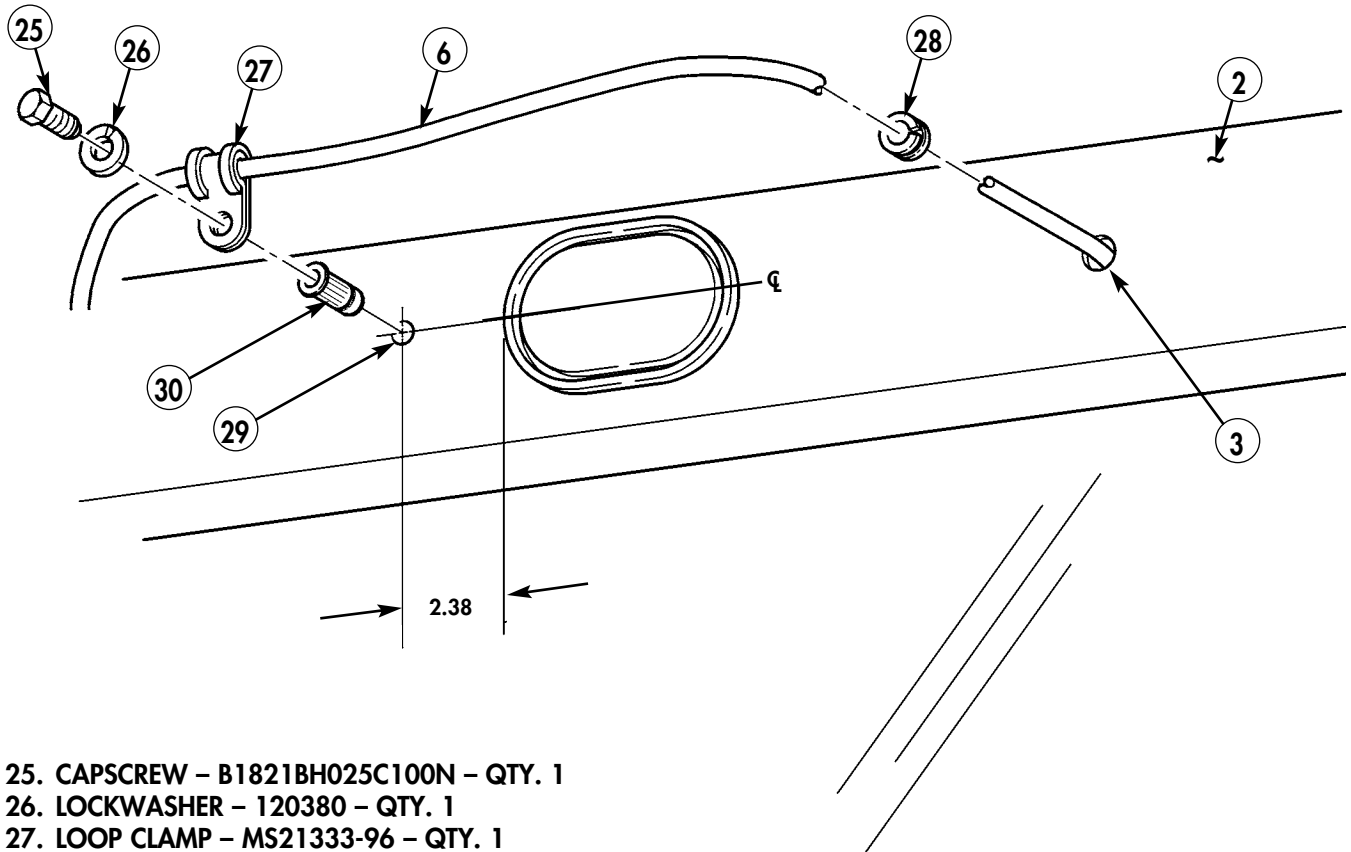

- 25. CAPSCREW - B1821BH025C100N - QTY. 1
- 26. LOCKWASHER - 120380 - QTY. 1
- 27. LOOP CLAMP - MS21333-96 - QTY. 1
- 28. GROMMET - MS35489-143 - QTY. 1
- 30. INSERT - 12446871-2 - QTY. 1

Figure 5-88.

- 33-17. Locate, mark, and drill two 0.147-in. diameter holes (35) in windshield center frame (36).
- 33-18. Route DAGR antenna cable (6) along windshield center frame (36) with two self-tapping screws (33), loop clamps (34) and (27), existing screw (31), and washer (32).

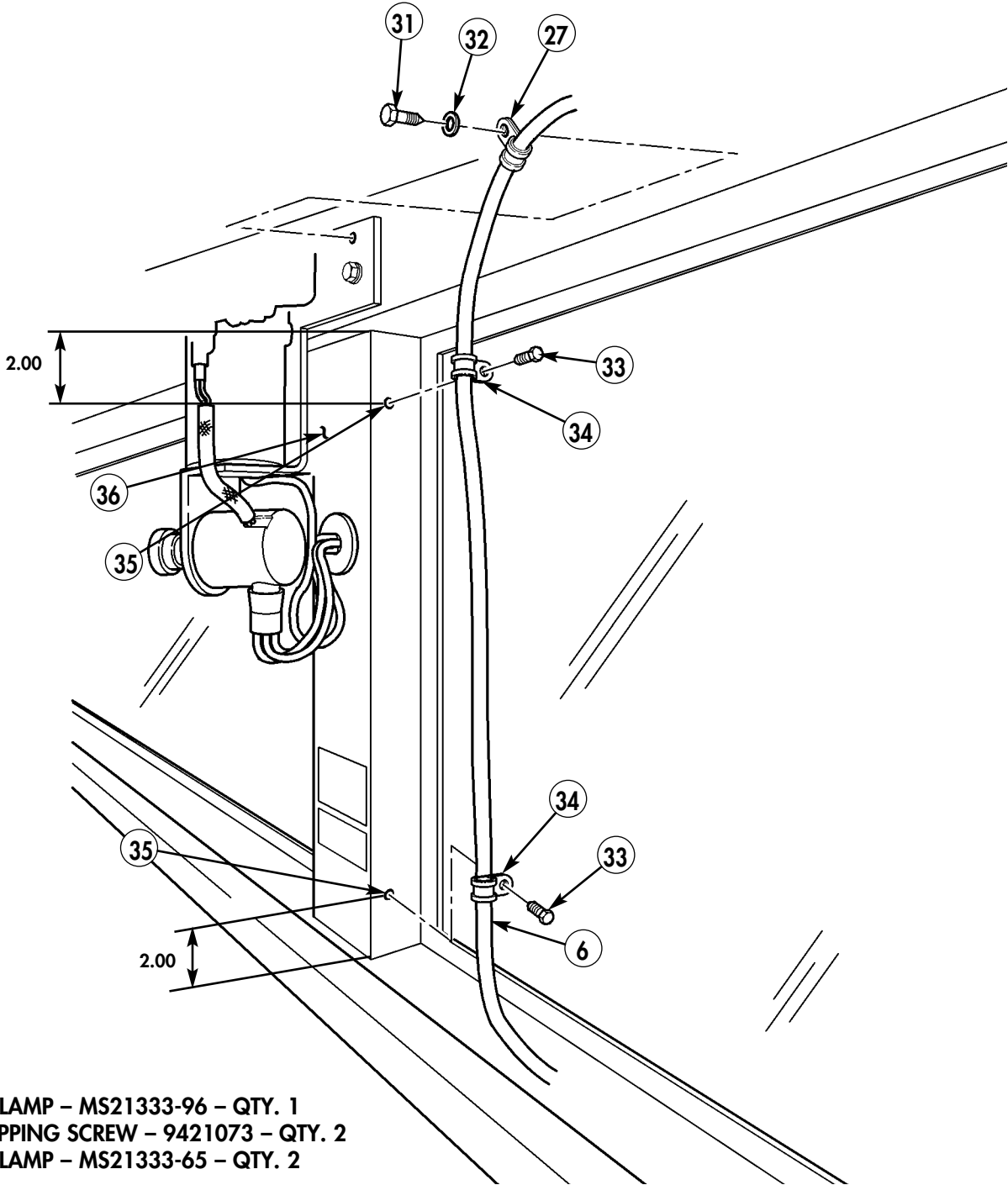

- 27. LOOP CLAMP – MS21333-96 – QTY. 1
- 33. SELF-TAPPING SCREW – 9421073 – QTY. 2
- 34. LOOP CLAMP – MS21333-65 – QTY. 2

Figure 5-89.

- 33-19. Locate, mark, and drill one 0.147-in. hole (42) in top of windshield frame (2).
- 33-20. Route DAGR antenna cable (6) on top of windshield frame (2) and secure with loop clamp (34) and self-tapping screw (33).
- 33-21. Route DAGR antenna cable (6) down through center access hole (37) of integrated rack (38), and coil excess antenna cable (6) under integrated rack (38).
- 33-22. Route DAGR power cable (40) from bracket (39) to right-side tunnel insulation (41).

**NOTE**

Loosen right-side tunnel insulation before performing step 33-23.  
(Refer to TM 9-2320-280-20.)

- 33-23. Route DAGR power cable (40) under edge of right-side tunnel insulation (41) to 24V terminal bar at cab enclosure panel.

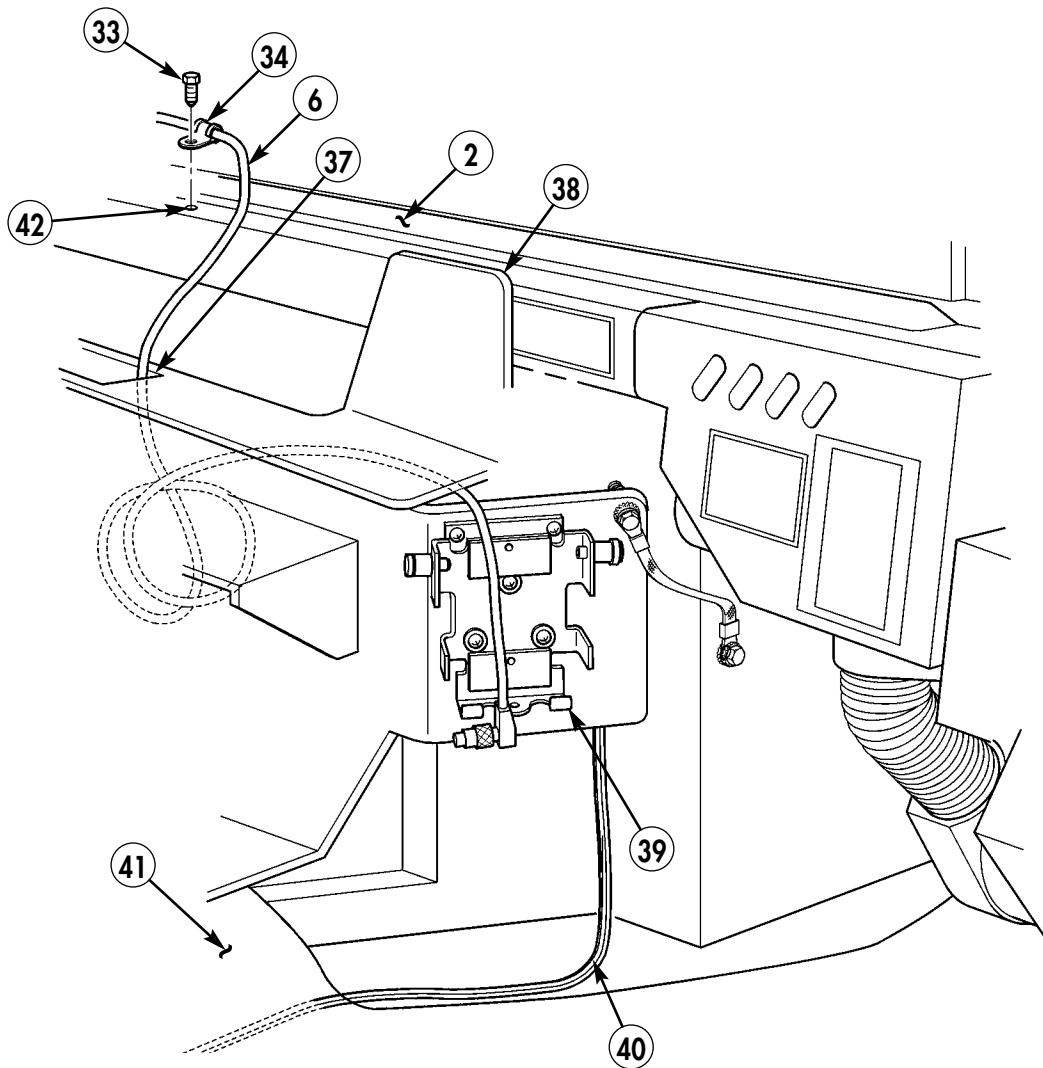

- 33. SELF-TAPPING SCREW – 9421073 – QTY. 1
- 34. LOOP CLAMP – MS21333-65 – QTY. 1
- 38. DAGR POWER CABLE – 9728558-10 – QTY. 1

Figure 5-90.

**NOTE**

DAGR power cable positive lead insulation is ribbed.

- 33-24.** Attach shrink tubing (46) and terminal lugs (44) and (50) to PLGR power cable negative lead (49) and DAGR power cable positive lead (47). (Refer to TM 9-2320-280-20 for terminal connector repair.)
- 33-25.** Attach DAGR power cable positive lead (47) to 24V terminal board (52) located on cab enclosure panel (43) with existing nut (45).
- 33-26.** Attach DAGR power cable negative lead (49) to ground strap (51) located on cab enclosure panel (43) with existing nut (45).
- 33-27.** Coil excess positive and negative power leads, place beneath ground strap, and secure with tiedown strap (48).

**NOTE**

Ensure all excess antenna cable is inside cab of vehicle.

- 33-28.** Coil excess antenna cable and store under integrated rack using tiedown strap as necessary. (Refer to figure 5-90.)
- 33-29.** Install right-side tunnel insulation. (Refer to TM 9-2320-280-20.)

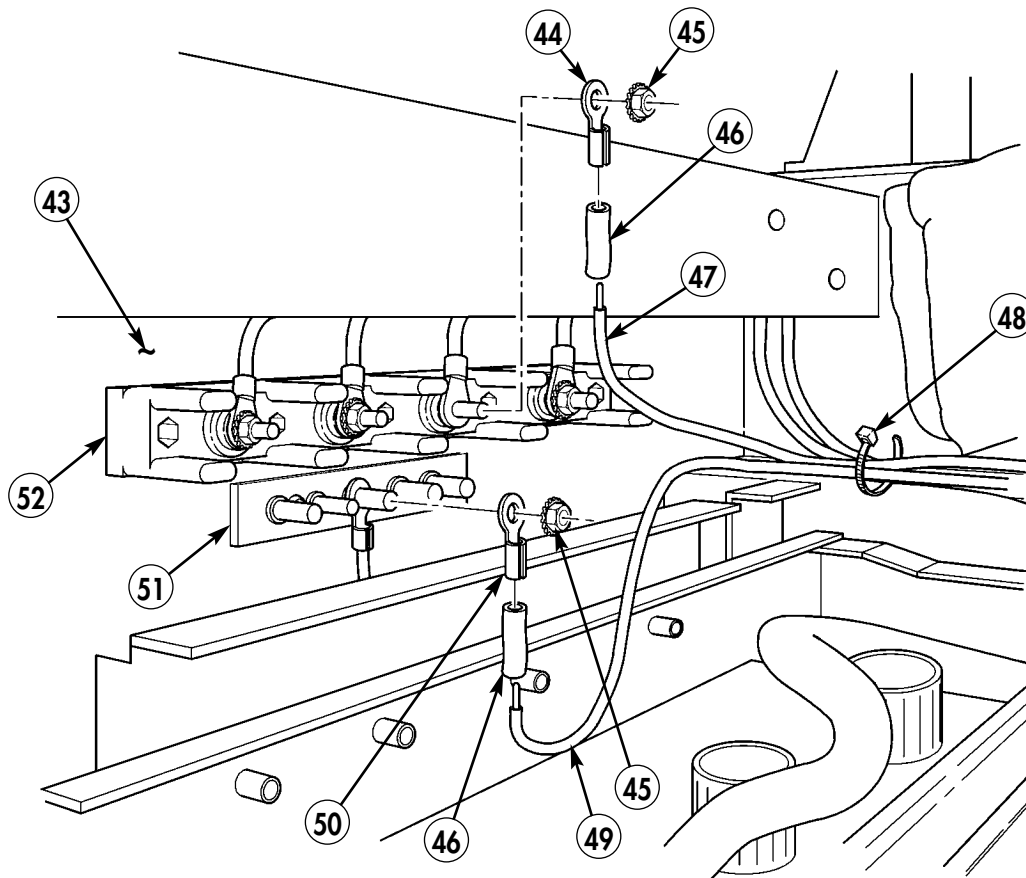

- 44. TERMINAL LUG – 7728780 – QTY. 1**
- 46. SHRINK TUBING – MS23053/4-302-0 – QTY. A/R**
- 48. TIEDOWN STRAP – MS3367-1-0 – QTY. A/R**
- 50. TERMINAL LUG – 7728777 – QTY. 1**

*Figure 5-91.*

**Section XXXIV. ARMOR AND ANTENNA INSTALLATION (WITH BOLT-ON ARMOR)**

**NOTE**

- DAGR shown, PLGR similar.
- Perform following steps for vehicles with bolt-on armor and antenna mounted on right side of windshield frame.
- It may be necessary to drill pilot hole prior to drilling 0.562-in. diameter hole.

**34-1.** Locate, mark, and drill one 0.562-in. diameter hole (1) on right side of A-pillar (2).

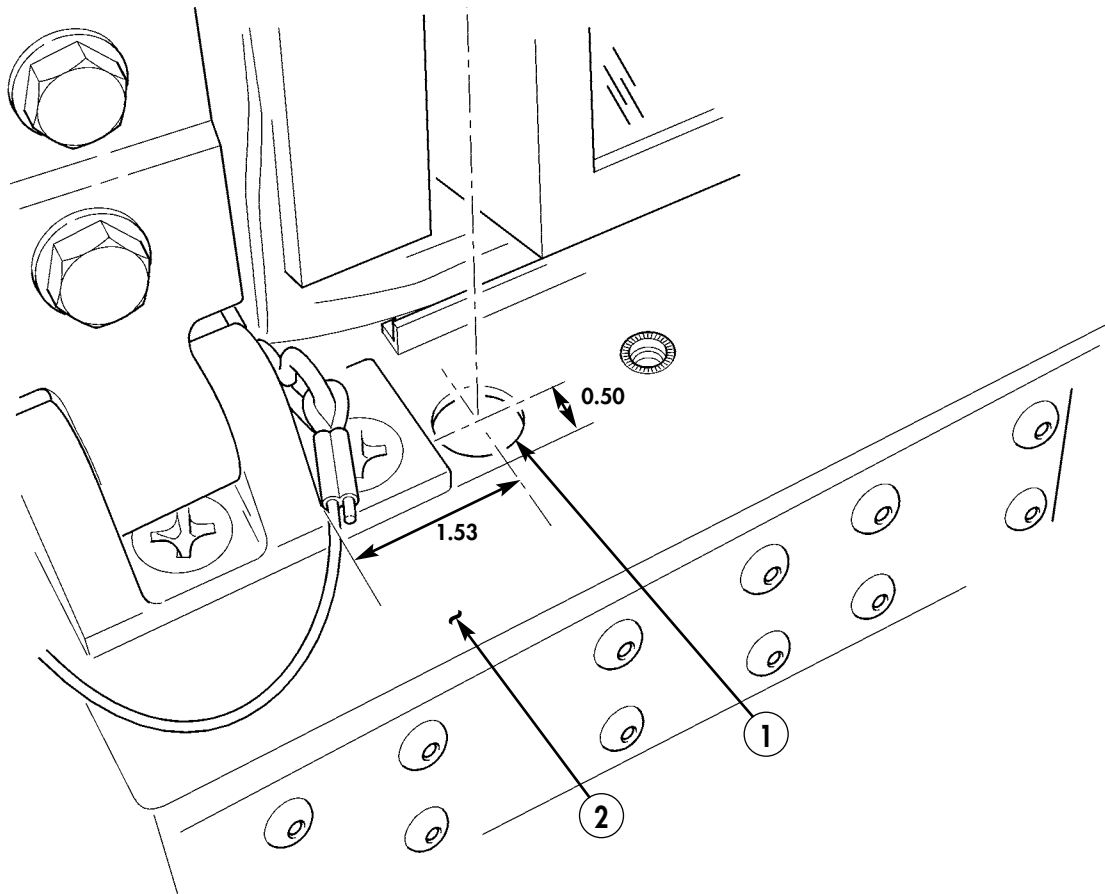

*Figure 5-92.*

- 34-2.** Using DAGR antenna mount (5) as a template, locate, mark, and drill two 0.281-in. diameter holes (16) in QEAM rack (11).
- 34-3.** Install DAGR antenna (3) to DAGR mount (5) with capscrew (20) and washer (21).
- 34-4.** Install DAGR mount (5) to QEAM rack (11) with two capscrews (10), washers (9), spacers (12), lockwashers (17), and nuts (18).
- 34-5.** Attach DAGR antenna cable (4) to DAGR antenna (3).
- 34-6.** Route antenna cable (4) down through DAGR antenna mount (5) and along windshield frame (15).
- 34-7.** Secure DAGR antenna cable (4) to DAGR mount (5) with loop clamp (19), capscrew (8), washer (7) and nut (6).
- 34-8.** Secure DAGR antenna cable (4) to QEAM rack (11) with loop clamp (13) and self-tapping screw (14).

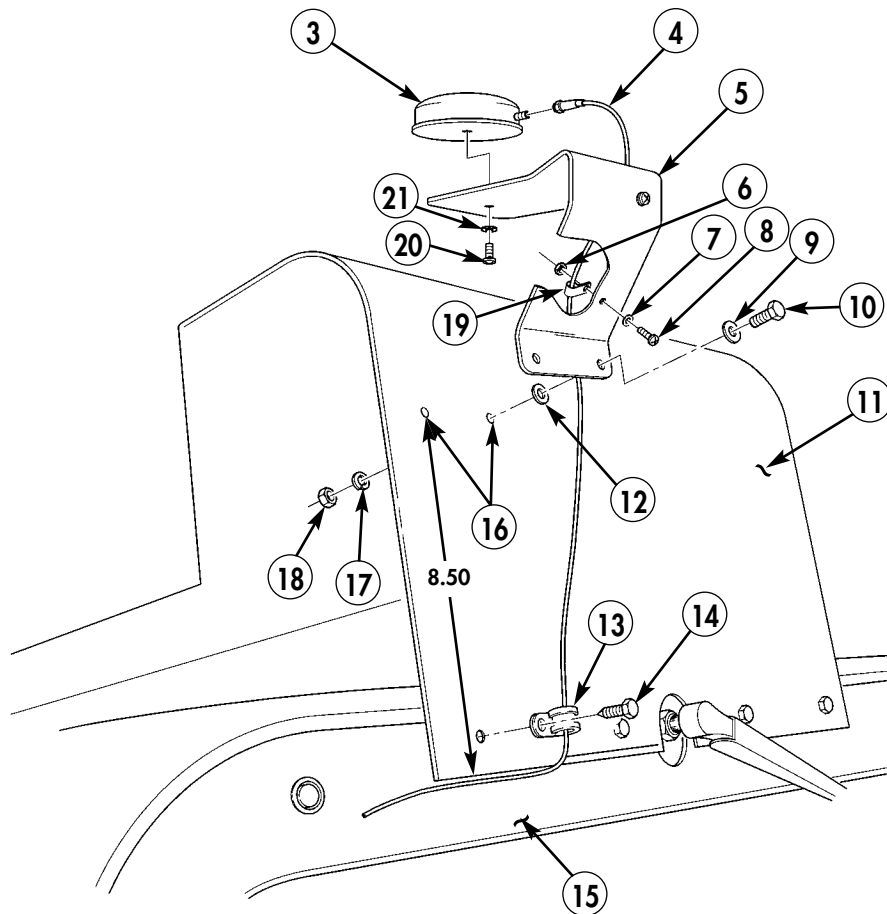

Figure 5-93.

- 9. WASHER – MS2436161 – QTY. 2**  
**10. CAPSCREW – B1821BH025C100N – QTY. 2**  
**12. SPACER – N/A – QTY. 2**  
**13. LOOP CLAMP – MS21333-98 – QTY. 1**  
**14. SELF-TAPPING SCREW – 9421073 – QTY. 1**  
**17. LOCKWASHER – MS35338-48 – QTY. 2**  
**18. NUT – 9419143 – QTY. 2**  
**20. SCREW – 160035 – QTY. 1**  
**21. WASHER – 9417373 – QTY. 1**

### Section XXXV. ANTENNA CABLE ROUTING (WITH BOLT-ON ARMOR)

#### NOTE

- DAGR shown, PLGR similar.
- Perform following steps for vehicles with bolt-on armor and antenna installed on right side of windshield frame.

**35-1.** Route antenna cable (1) through hole (5).

**35-2.** Remove self-tapping screw (4) from right capping ring (2).

**35-3.** Secure antenna cable (1) to right capping ring (2) with clamp (3) and existing self-tapping screw (4).

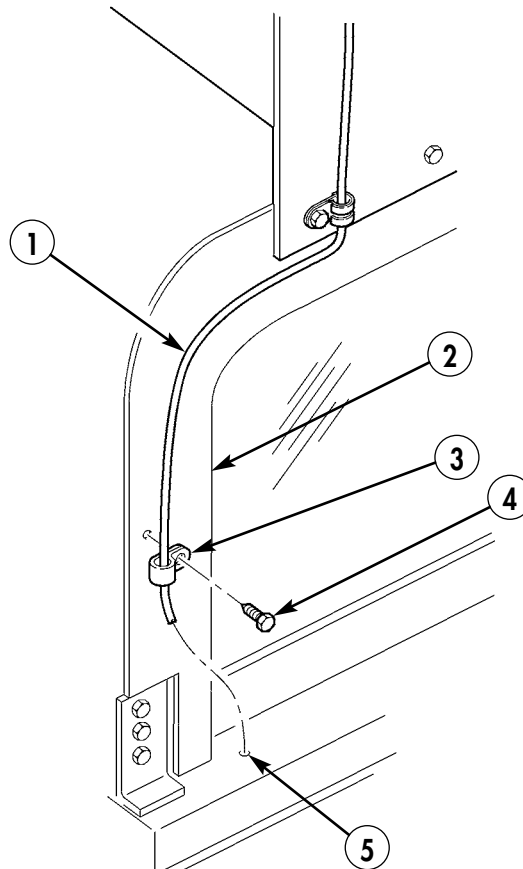

- 1. ANTENNA CABLE - 426-0141-050 - QTY. 1
- 3. CLAMP - MS21333-96 - QTY. 1

Figure 5-94.



- 35-4. Split grommet (7) and install on antenna cable (1).
- 35-5. Wrap electrical tape (6) around antenna cable (1).
- 35-6. Install antenna cable (1) with electrical tape (6) in grommet (7).

**NOTE**

Apply sealing compound on grommet.

- 35-7. Install grommet (7) in hole (5) on A-pillar (8).

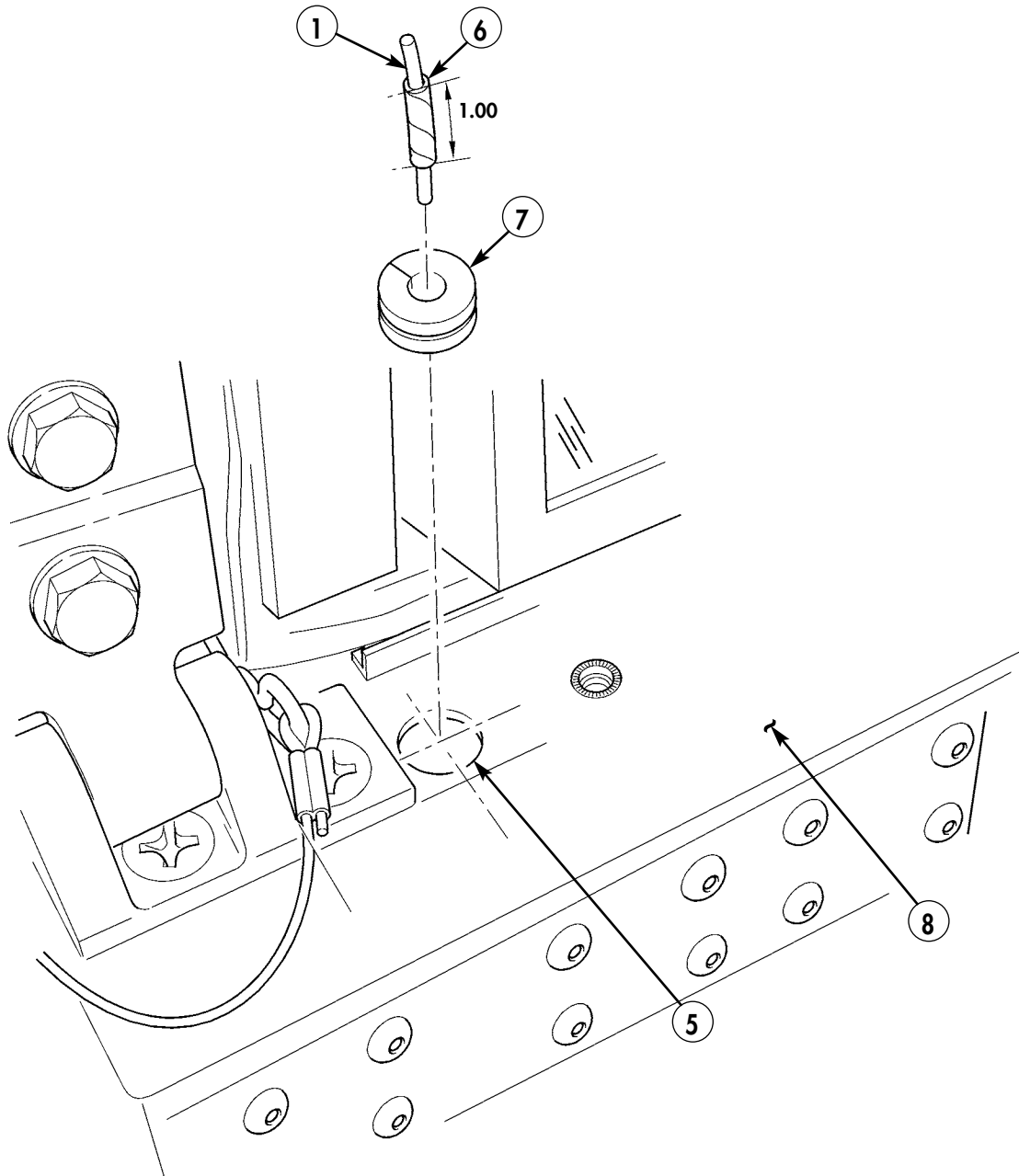

- 6. ELECTRICAL TAPE – HH-I-595 – QTY. A/R
- 7. GROMMET – MS35489-31 – QTY. 1

Figure 5-95.

- 35-8. Route antenna cable (1) behind heater shield (11) to installation mount (12).
- 35-9. Locate, mark, and drill one 0.147-in. diameter hole (15) in plenum (8).
- 35-10. Secure antenna cable (1) to plenum (8) with clamp (10) and self-tapping screw (9).
- 35-11. Secure excess antenna cable (1) behind installation mount (12) on integrated radio rack (14) with tiedown strap (13).

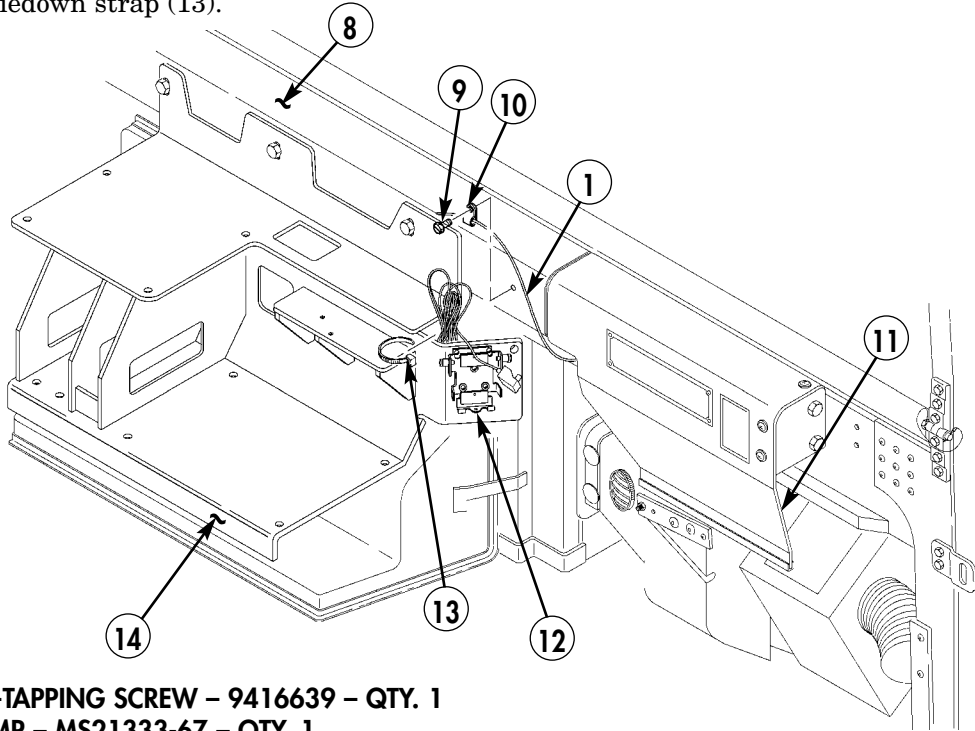

- 9. SELF-TAPPING SCREW – 9416639 – QTY. 1
- 10. CLAMP – MS21333-67 – QTY. 1
- 13. TIEDOWN STRAP – MS3367-1-0 – QTY. 1

Figure 5-96.

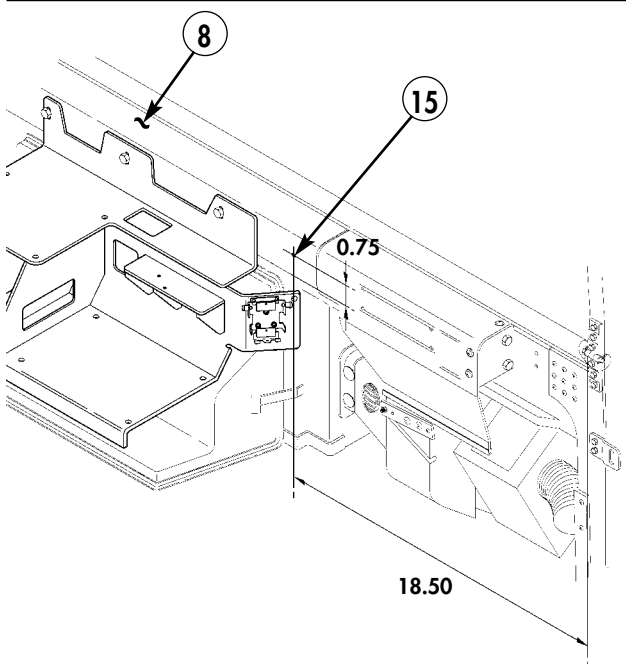

M998A2 SERIES

Figure 5-97.

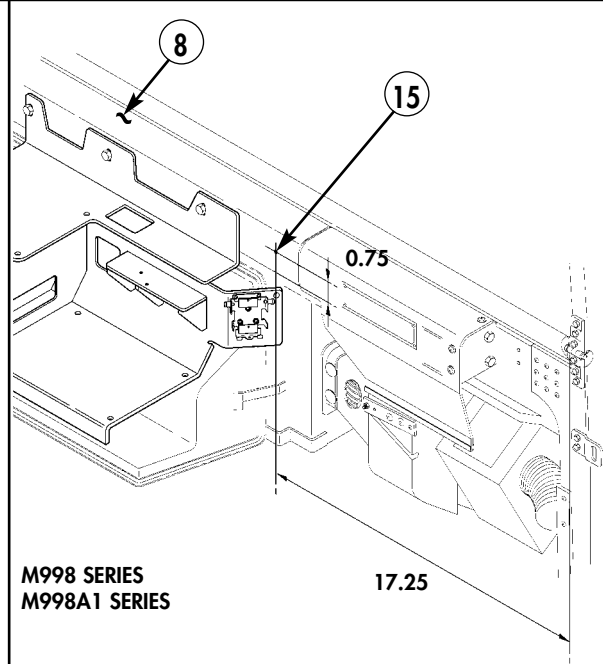

M998 SERIES  
M998A1 SERIES

Figure 5-98.

**NOTE**

DAGR power cable positive lead insulation is ribbed.

- 35-12. Attach shrink tubing (18) and terminal lugs (16) and (22) to PLGR power cable negative lead (21) and DAGR power cable positive lead (19). (Refer to TM 9-2320-280-20 for terminal connector repair.)
- 35-13. Attach DAGR power cable positive lead (19) to 24V terminal board (24) located on cab enclosure panel (25) with existing nut (17).
- 35-14. Attach DAGR power cable negative lead (21) to ground strap (23) located on cab enclosure panel (25) with existing nut (17).
- 35-15. Coil excess positive and negative power leads, place beneath ground strap, and secure with tiedown strap (20).

**NOTE**

Ensure all excess antenna cable is inside cab of vehicle.

- 35-16. Coil excess antenna cable and store under integrated rack using tiedown strap as necessary. (Refer to figure 5-94.)
- 35-17. Install right-side tunnel insulation. (Refer to TM 9-2320-280-20.)

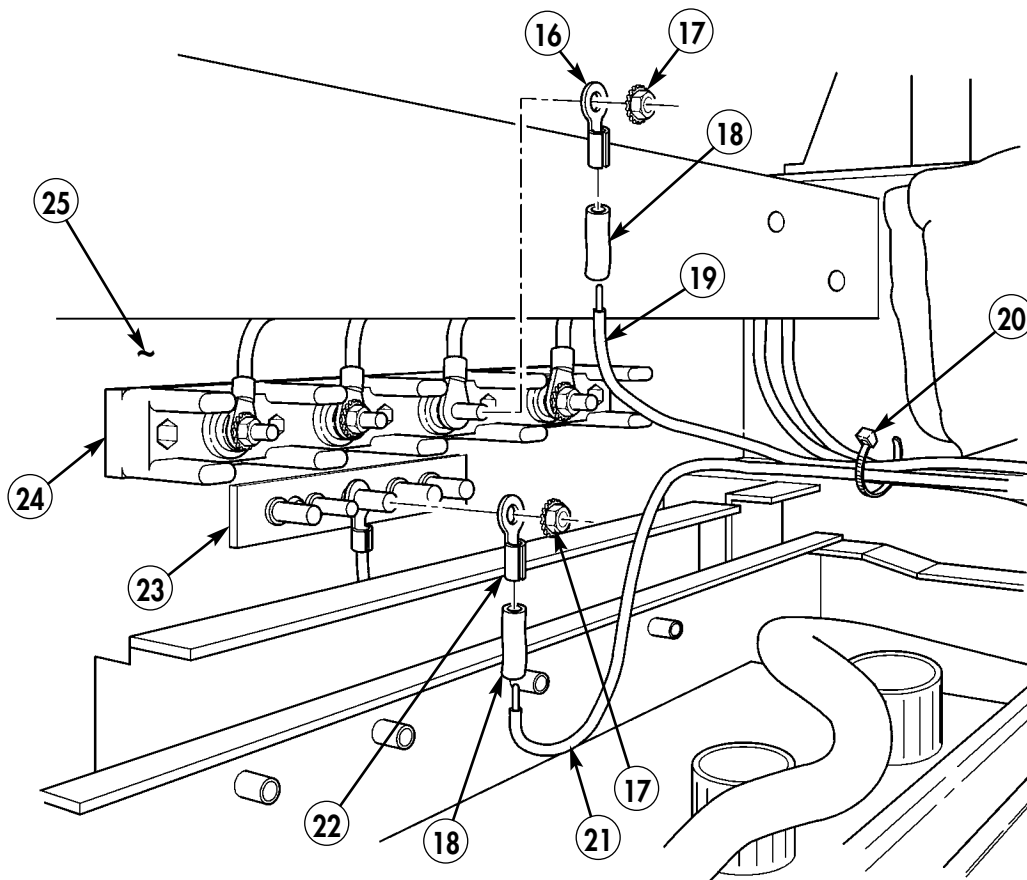

- 16. TERMINAL LUG - 7728780 - QTY. 1
- 18. SHRINK TUBING - MS23053/4-302-0 - QTY. A/R
- 20. TIEDOWN STRAP - MS3367-1-0 - QTY. A/R
- 22. TERMINAL LUG - 7728777 - QTY. 1

Figure 5-99.

**Section XXXVI. LOUDSPEAKER CABLES INSTALLATION ON MULTI-NET RACK**

**36-1.** Connect speaker cables (3) to loudspeakers (1).

**36-2.** Route speaker cables (3) under lower shelf of multi-net rack (2).

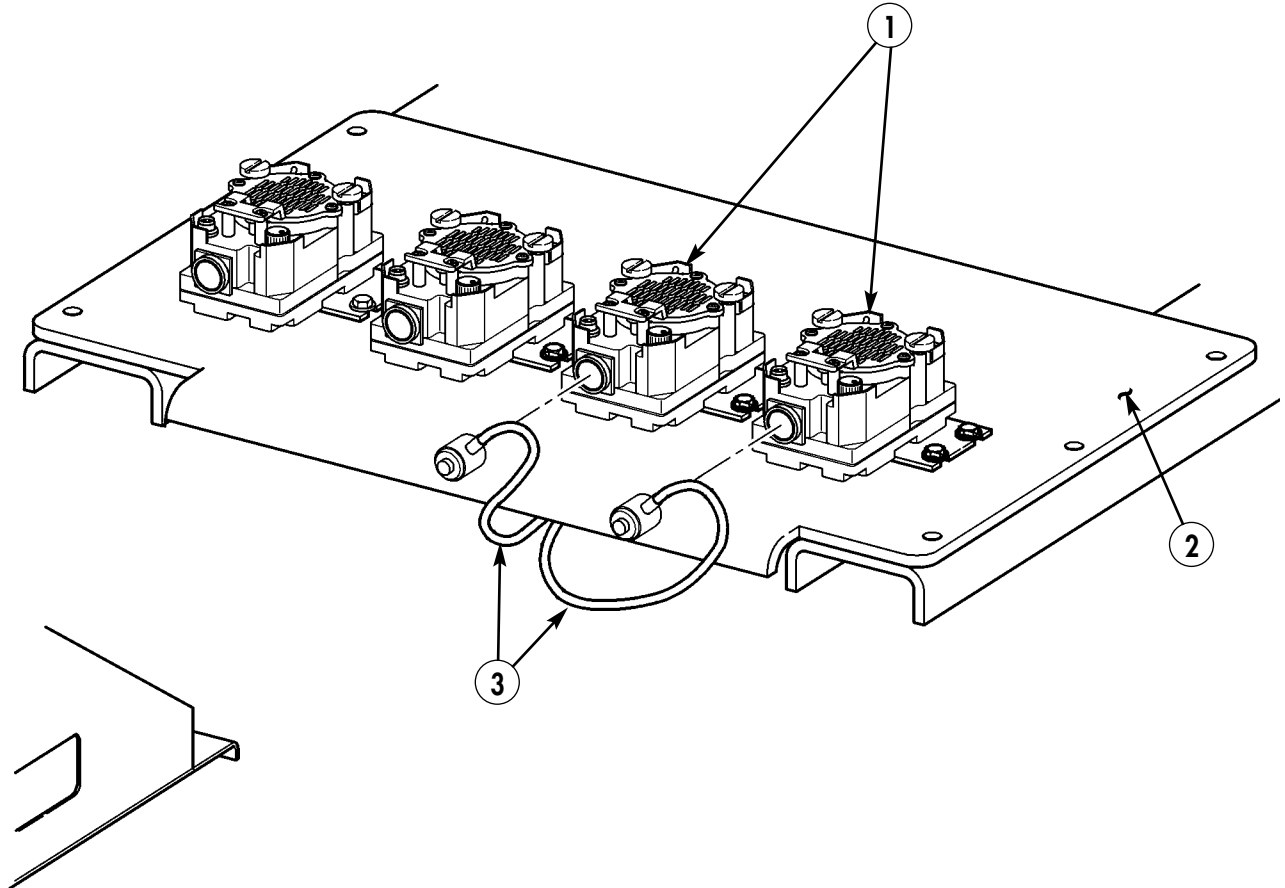

**3. LOUDSPEAKER CABLE – A3014038-3 – QTY. 2**

*Figure 5-100.*

**36-3.** Connect two speaker cables (3) to bottom SINCGARS mounting base MT-6352/VRC (4).

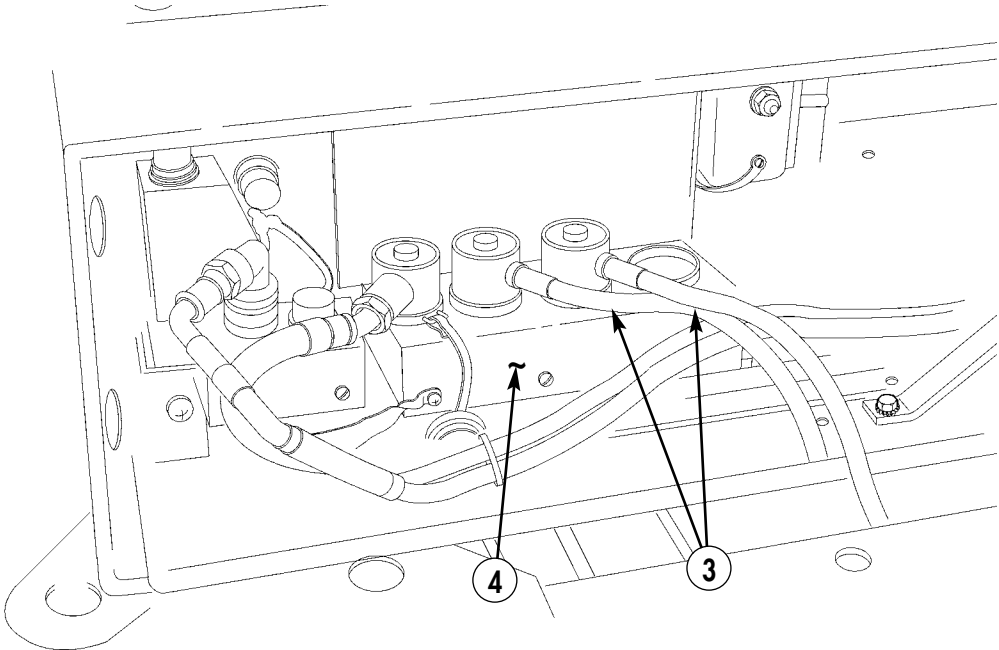

*Figure 5-101.*

**36-4.** Connect two speaker cables (3) to two loudspeakers (1). Route two speaker cables (3) under lower shelf of multi-net rack (2).

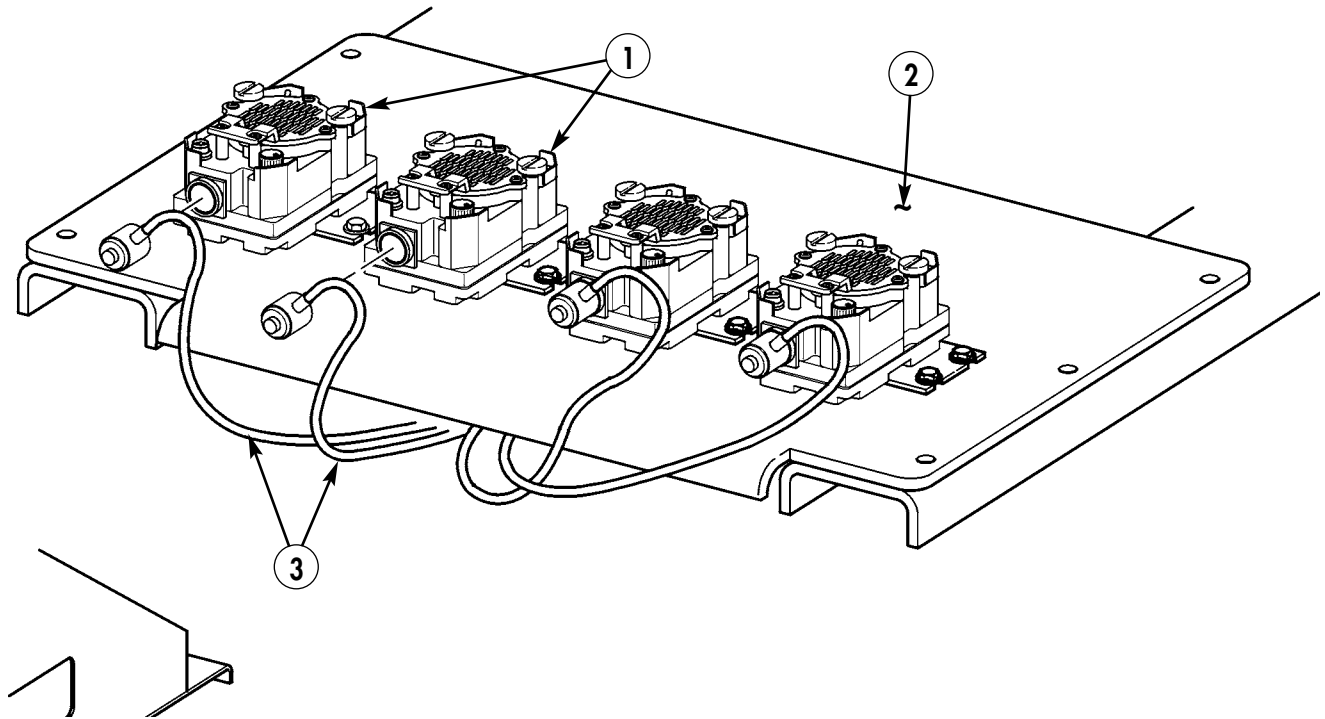

*Figure 5-102.*

**3. LOUDSPEAKER CABLE – A3014038-3 – QTY. 2**

**36-5.** Connect two speaker cables (3) to top SINCGARS mounting base MT-6352/VRC (5).

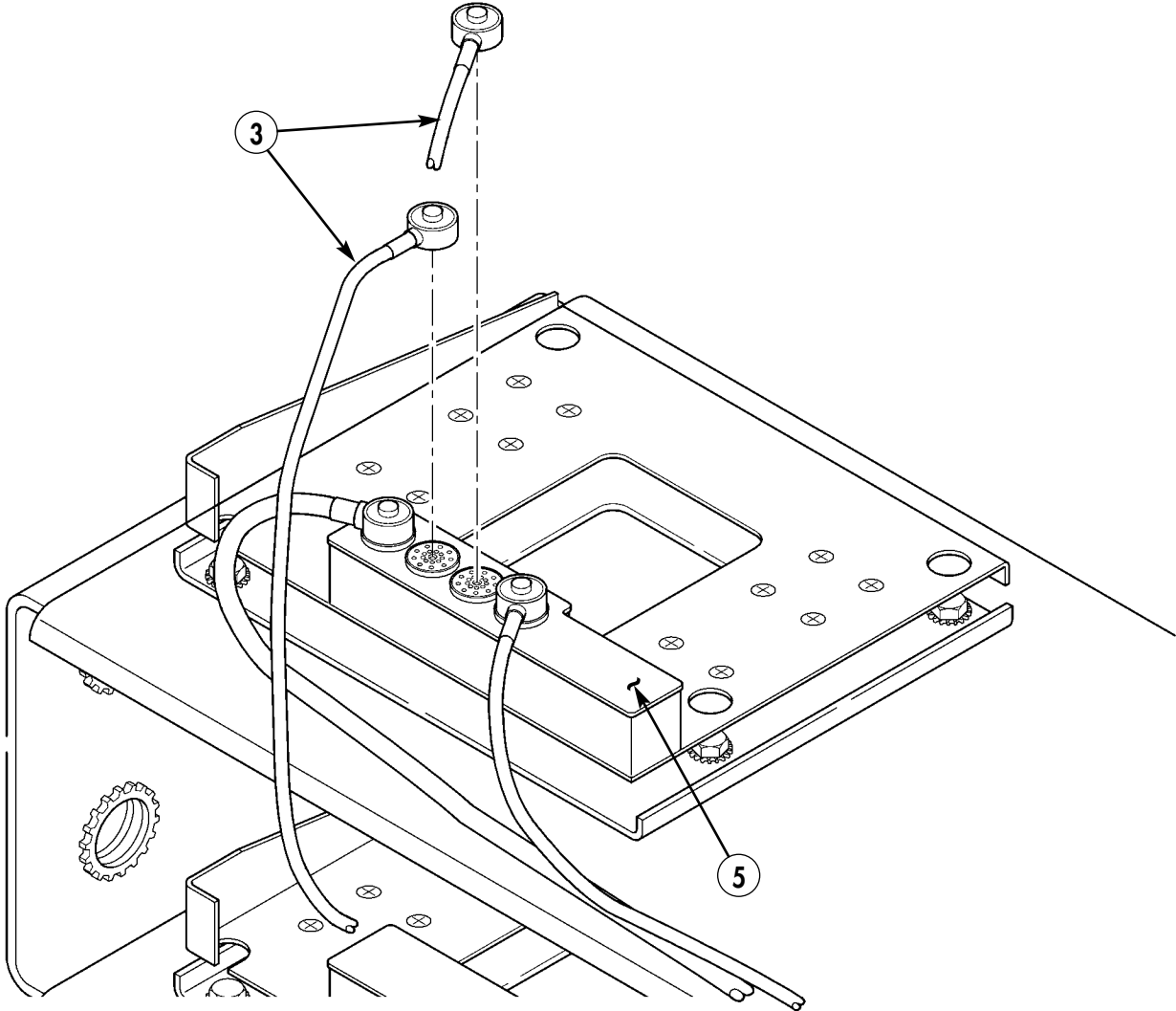

*Figure 5-103.*

## Section XXXVII. SINCGARS CABLES INSTALLATION

### NOTE

- This procedure applies to vehicles without existing antennas. For vehicles with existing antennas, remove all control cables. (Refer to TM 9-2320-280-20.)
- Previously routed cables have been removed from figure 5-104 for clarity.

- 37-1.** Route antenna cable (15) from left side of mounting base (19), down through center access hole (12), under integrated rack (13), and under right-side tunnel insulation (16) towards rear of vehicle.
- 37-2.** Route antenna cable (17) from mounting base (19) to MT-6353/VRC mounting base (18).
- 37-3.** Route power amp cable (10) from MT-6353/VRC mounting base (18), up through center access hole (12), and connect power amp cable (10) to connector on W1J1 cable (9).
- 37-4.** Route control cable (11) from MT-6353/VRC mounting base (18), up through center access hole (12), to mounting base (19).
- 37-5.** Route antenna cable (14) from front of MT-6353/VRC mounting base (18) and under integrated rack (13).
- 37-6.** Route two loudspeaker cables (2L) and (2R) from mounting base (19) up along windshield center post (20) and secure with three loop clamps (4), two existing self-tapping screws (8), and existing screw (21).
- 37-7.** Route left side loudspeaker cable (2L) along windshield frame (7) and secure with two loop clamps (3) and existing screws (22). Connect speaker cable (2L) to left speaker (1).
- 37-8.** Route right side loudspeaker cable (2R) around right speaker (5) and secure to windshield frame (7) with loop clamp (3) and existing screw (6). Connect right speaker cable (2R) to right speaker (5).

- 2L. LOUDSPEAKER CABLE – A3014038-3 – QTY. 1  
 2R. LOUDSPEAKER CABLE – A3014038-3 – QTY. 1  
 3. LOOP CLAMP – MS21333-102 – QTY. 3  
 4. LOOP CLAMP – MS21333-104 – QTY. 3  
 14. ANTENNA CABLE – A3014031-17 – QTY. 1  
 15. ANTENNA CABLE – A3014031-8 – QTY. 1  
 17. ANTENNA CABLE – A3014032-3 – QTY. 1

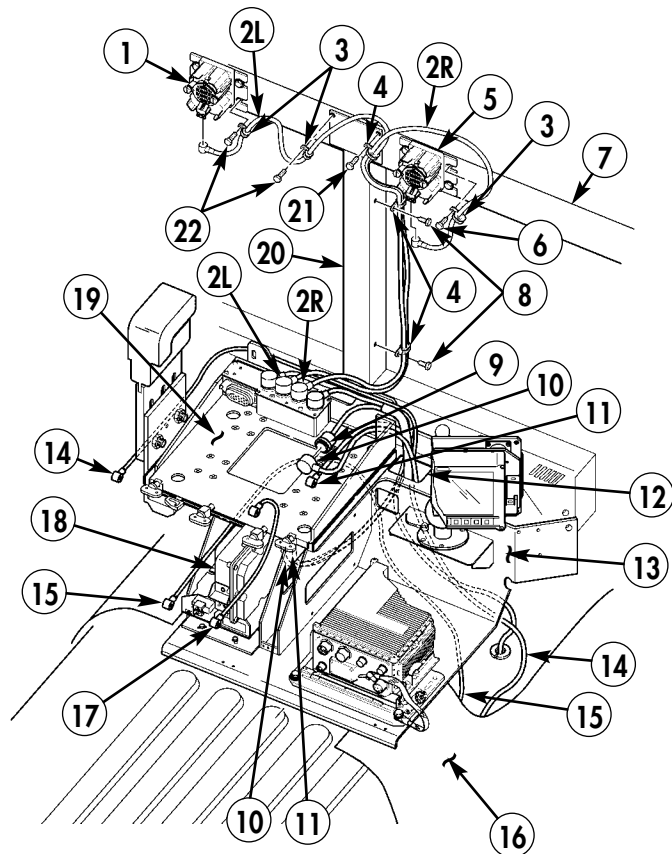
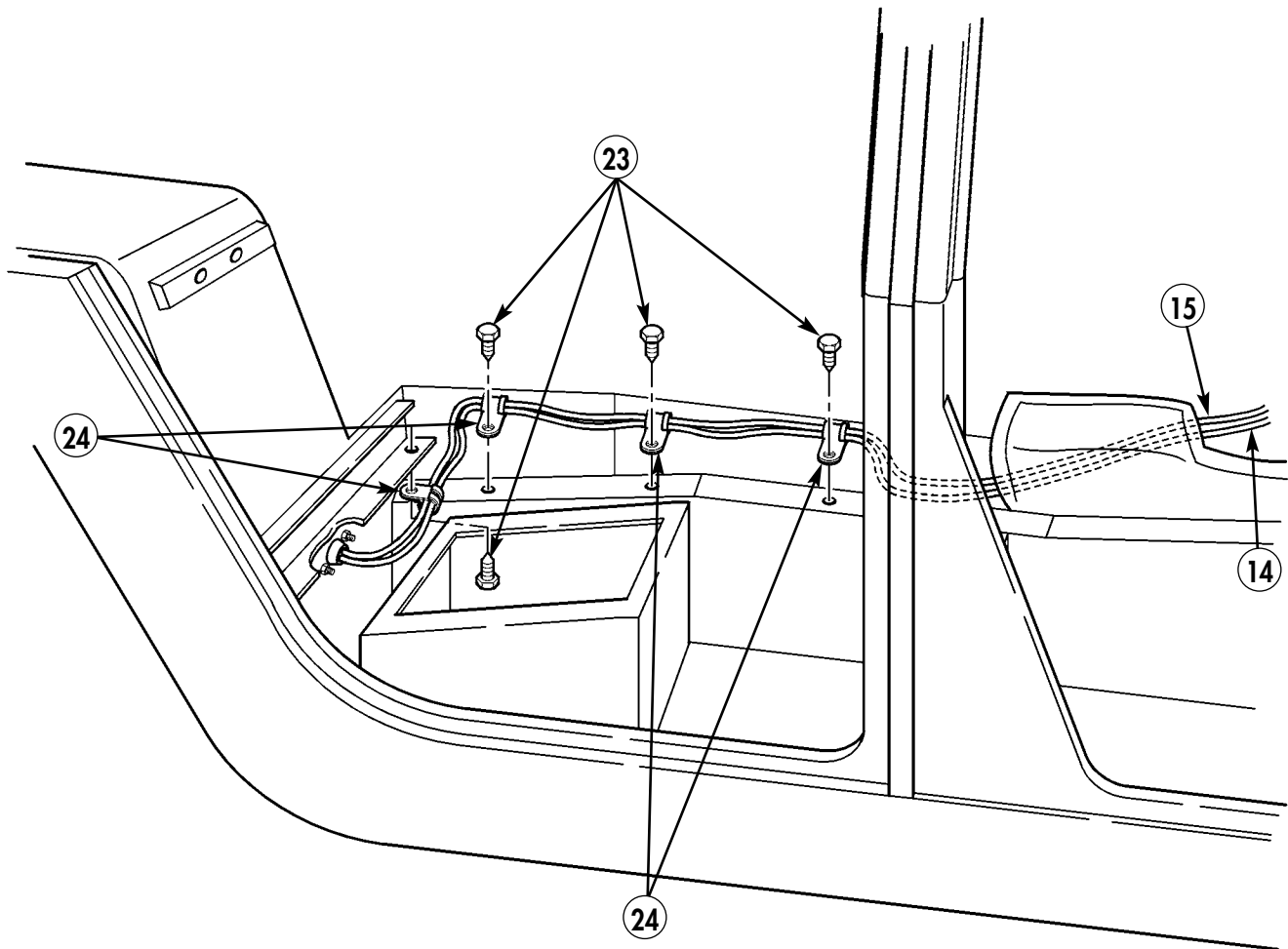

Figure 5-104.



- 37-6.** Route two antenna cables (15) and (14) along right rear seat/utility area with four self-tapping screws (23) and loop clamps (24).
- 37-7.** Route two antenna cables (15) and (14) through right wheelwell/utility area with existing grommet, retainer, screws, and plain-assembled nuts. (Refer to TM 9-2320-280-20.)



- 23. SELF-TAPPING SCREW - 9421073 - QTY. 4**  
**24. LOOP CLAMP - MS21333-69 - QTY. 4**

*Figure 5-105.*

- 37-8.** Route two antenna cables (14) and (15) along front wheelwell seam (26) and along front (44), intermediate (43), and rear (42) cargo bed supports. Secure with two self-tapping screws (29), loop clamps (27), screw (28), loop clamp (27), nut (25), and existing self-tapping screw (30) and loop clamp (41).
- 37-9.** Route antenna cable (14) along taillight wiring harness with two existing loop clamps (39) and (38), self-tapping screws (30), and lockwashers (37).
- 37-10.** Route antenna cable (14) to antenna base (40) with existing loop clamp (33), nut (35), lockwasher (34), washer (32), and screw (31).
- 37-11.** Attach antenna cable (14) to antenna base (40).
- 37-12.** Coil excess antenna cable (14) and secure to inside of taillight closeout cover with tiedown strap (36).

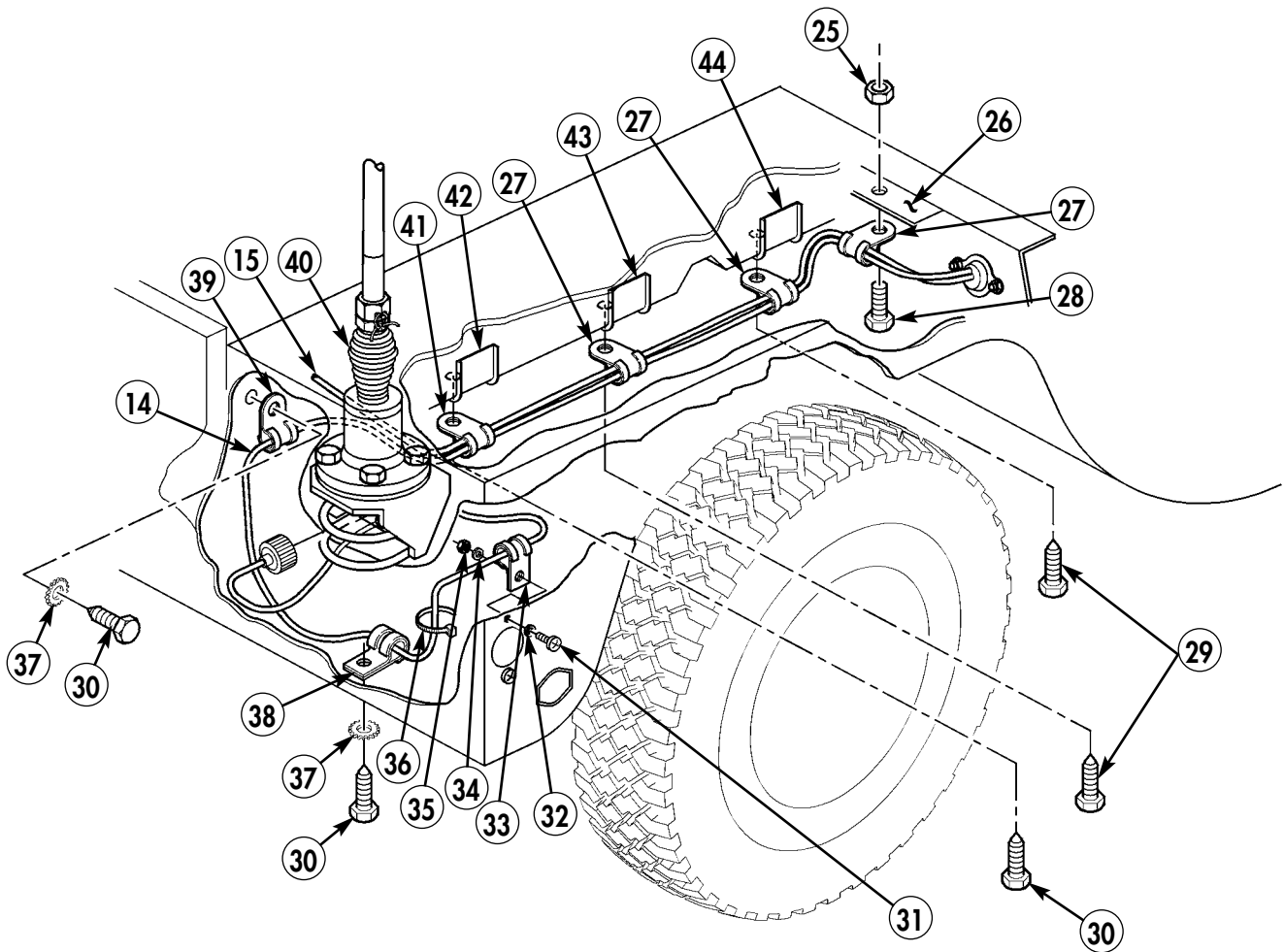

- 25. NUT – MS35650-302 – QTY. 1**
- 27. LOOP CLAMP – MS21333-69 – QTY. 3**
- 28. SCREW – MS35224-65 – QTY. 1**
- 29. SELF-TAPPING SCREW – 9421073 – QTY. 2**
- 36. TIEDOWN STRAP – MS3367-1-0 – QTY. A/R**

Figure 5-106.

- 37-13.** Route antenna cable (15) along existing taillight wiring harness (51) on rear cargo bed support (42) and secure with four existing loop clamps (52), (53), (54), (55), and existing self-tapping screws (49).
- 37-14.** Route antenna cable (15) along existing taillight wiring harness (51) on left-side frame rail with existing loop clamp (56), and screw (49).
- 37-15.** Route antenna cable (15) along existing taillight wiring harness (51) on rear cargo bed support (42) with existing loop clamps (57) and (58), screws (49), and lockwashers (50).
- 37-16.** Route antenna cable (15) to antenna base (45) with existing loop clamp (46), screw (59), lockwasher (47), and nut (48).
- 37-17.** Attach antenna cable (15) to antenna base (45).
- 37-18.** Coil excess antenna cable (15) and secure to inside of taillight closeout cover with tiedown strap (36).

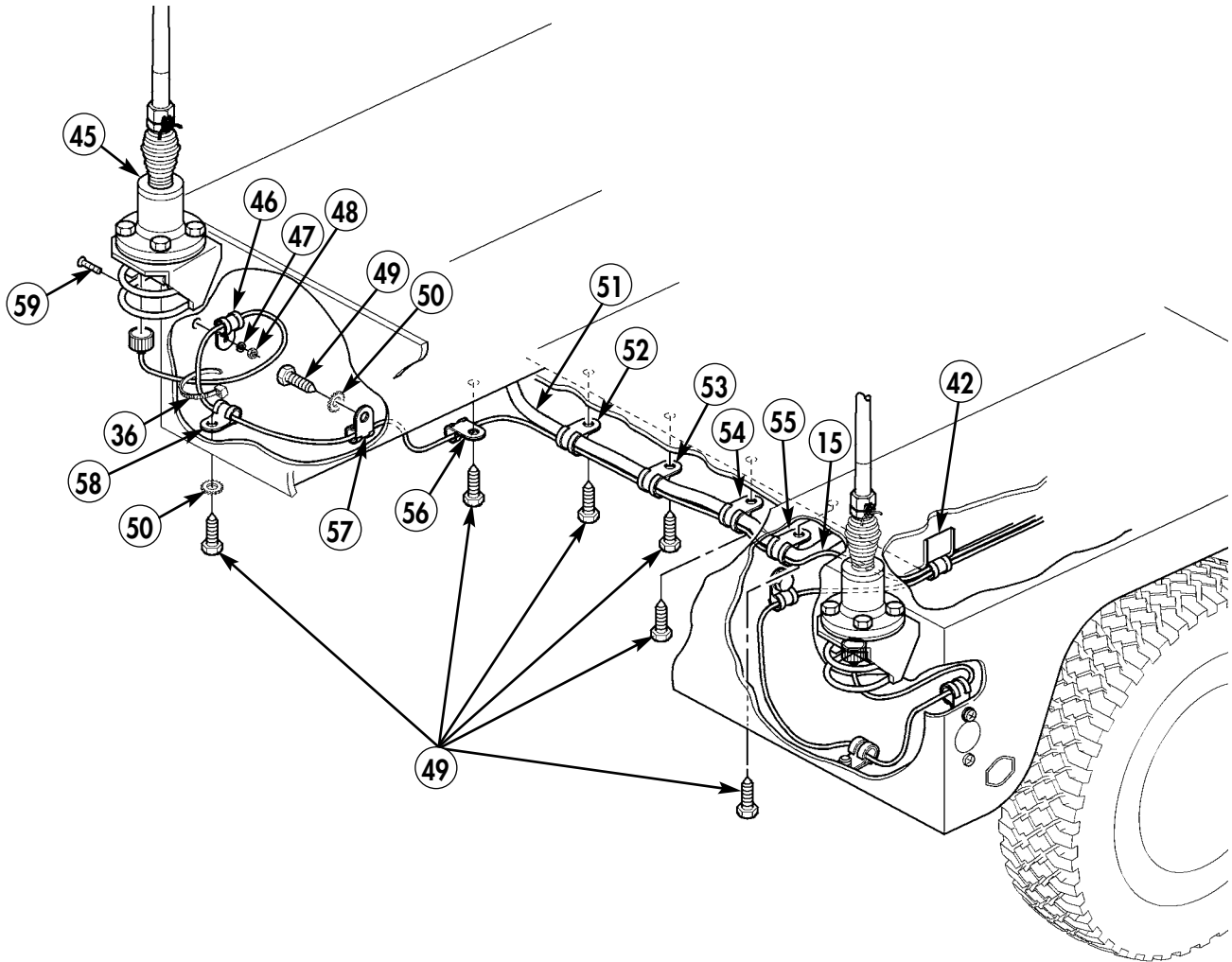

**36. TIEDOWN STRAP – MS3367-1-0 – QTY. A/R**

*Figure 5-107.*

## SECTION XXXVIII. SINGARS ON RIGHT-SIDE PEDESTAL MOUNT CABLES INSTALLATION

- 38-1. Locate, mark, and drill one 0.225-in. hole (8) in inboard corner on rear inside lip of left rear seat back support (6).
- 38-2. Locate, mark, and drill two 0.147-in. holes (5) in front face of right rear wheelwell (13).
- 38-3. Route antenna cable (4) along rear perimeter of right rear seat back support (6), up front face of left rear wheelwell (13), and up antenna base (1).

### NOTE

Clamps are large to accommodate black charger cable from power entry box in step 38-4.

- 38-4. Secure SINGARS antenna cable (4) to seat back support (6) with screw (7), lockwasher (9), nut (10), two self-tapping screws (12), two existing screws (2), and five loop clamps (3).
- 38-5. Secure antenna cable (4) to antenna base (1) with clamps (16), existing screws (17), washers (15), lockwashers (14), and nuts (18).
- 38-6. Connect antenna cable (4) to antenna (19). Route antenna cable (4) through multi-net rack (11) to vicinity of SINGARS mount.
- 38-7. Tighten all screws and nuts on all clamps.
- 38-8. Secure right-side tunnel insulation. (Refer to TM 9-2320-280-20.)

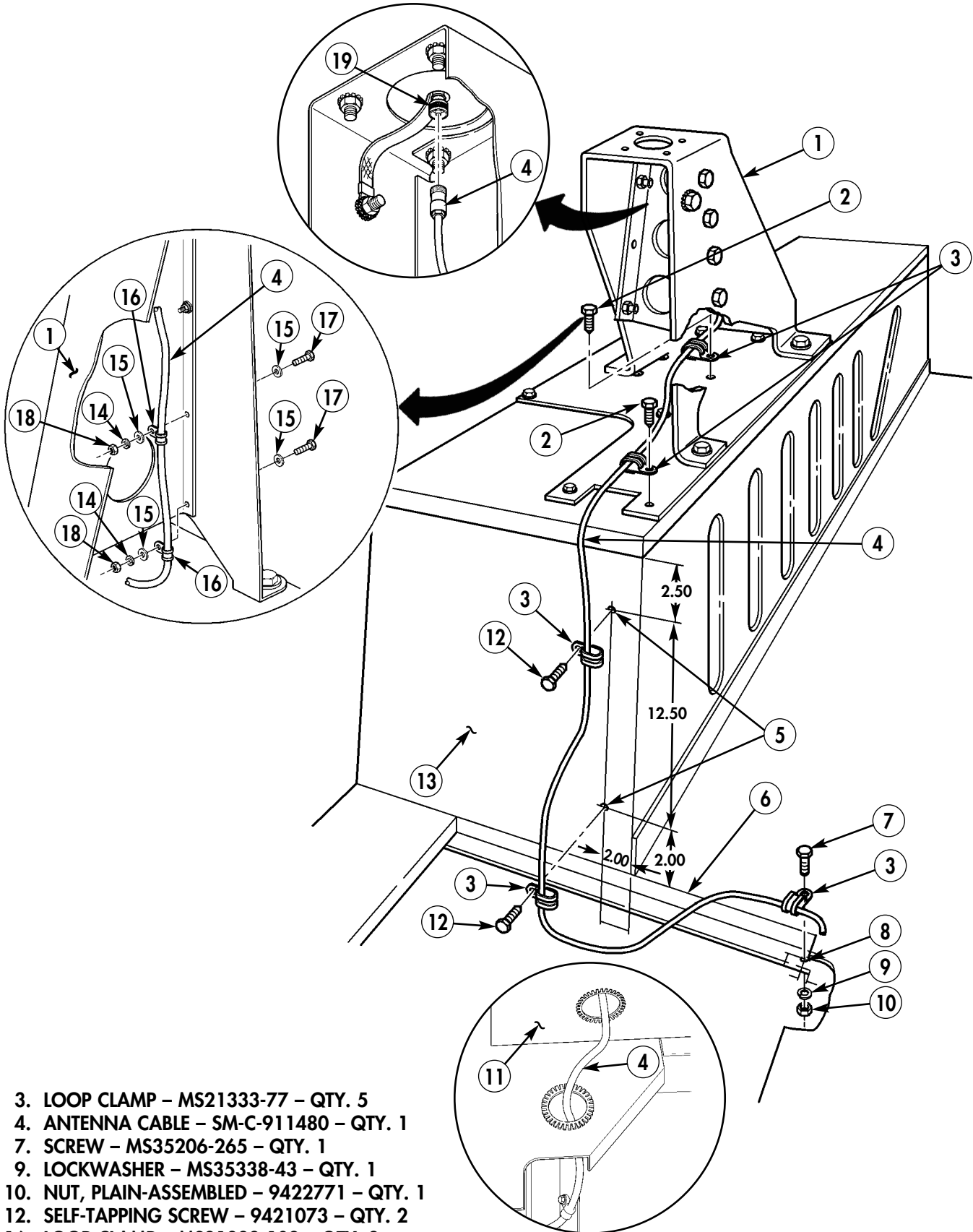

Figure 5-108.

38-9. Route SINCGARS antenna cable (4) to SINCGARS mount (23) on bottom shelf of multi-net rack (22).

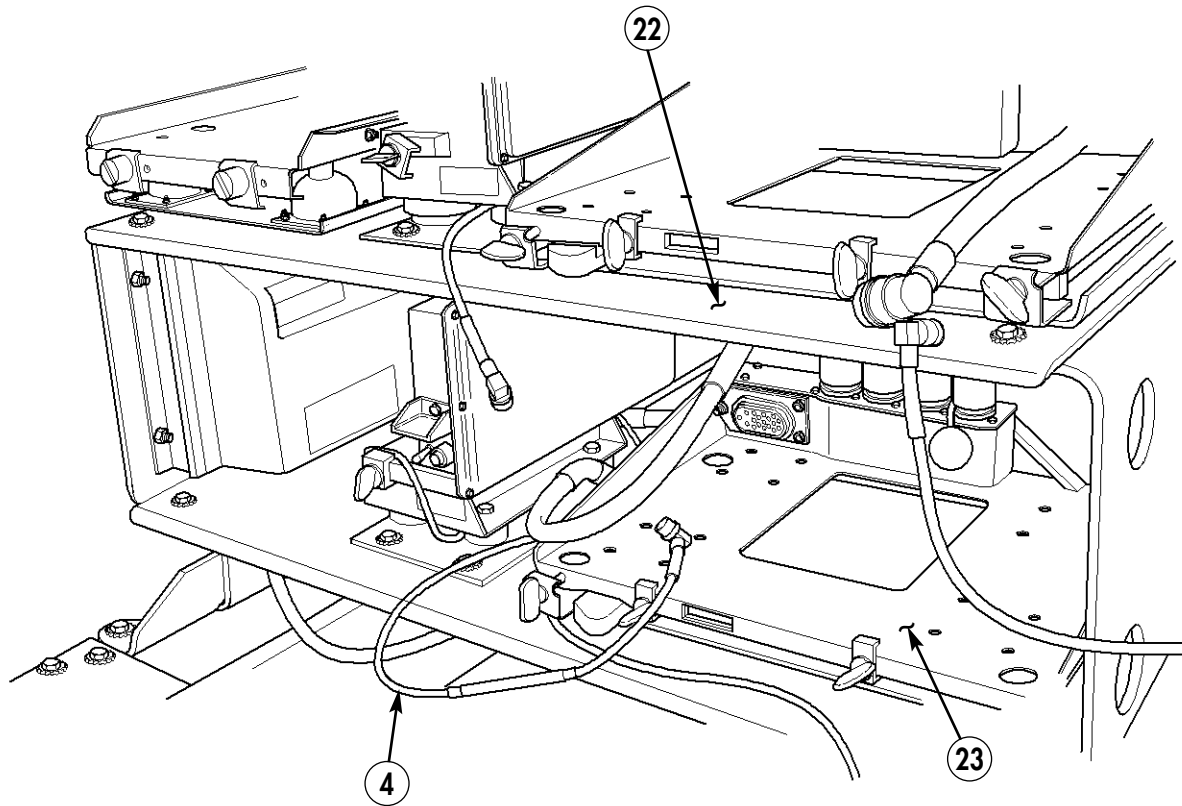

Figure 5-109.

## Section XXXIX. EPLRS CABLES AND NTRD ANTENNA CABLE INSTALLATION

### NOTE

- Loosen tunnel insulation before performing steps 39-1 and 39-2.  
(Refer to TM 9-2320-280-20.)
- SINCGARS model AN/VRC-92F shown.

- 39-1.** Route INC-EPUU cable (1) from integrated rack (3), down through center access hole (2), and under left-side tunnel insulation (5) towards rear of vehicle.
- 39-2.** Route power cable (4) from rear battery box forward and under integrated rack (3) and under left-side tunnel insulation (5) towards rear of vehicle.
- 39-3.** Secure left-side tunnel insulation (5). (Refer to TM 9-2320-280-20.)

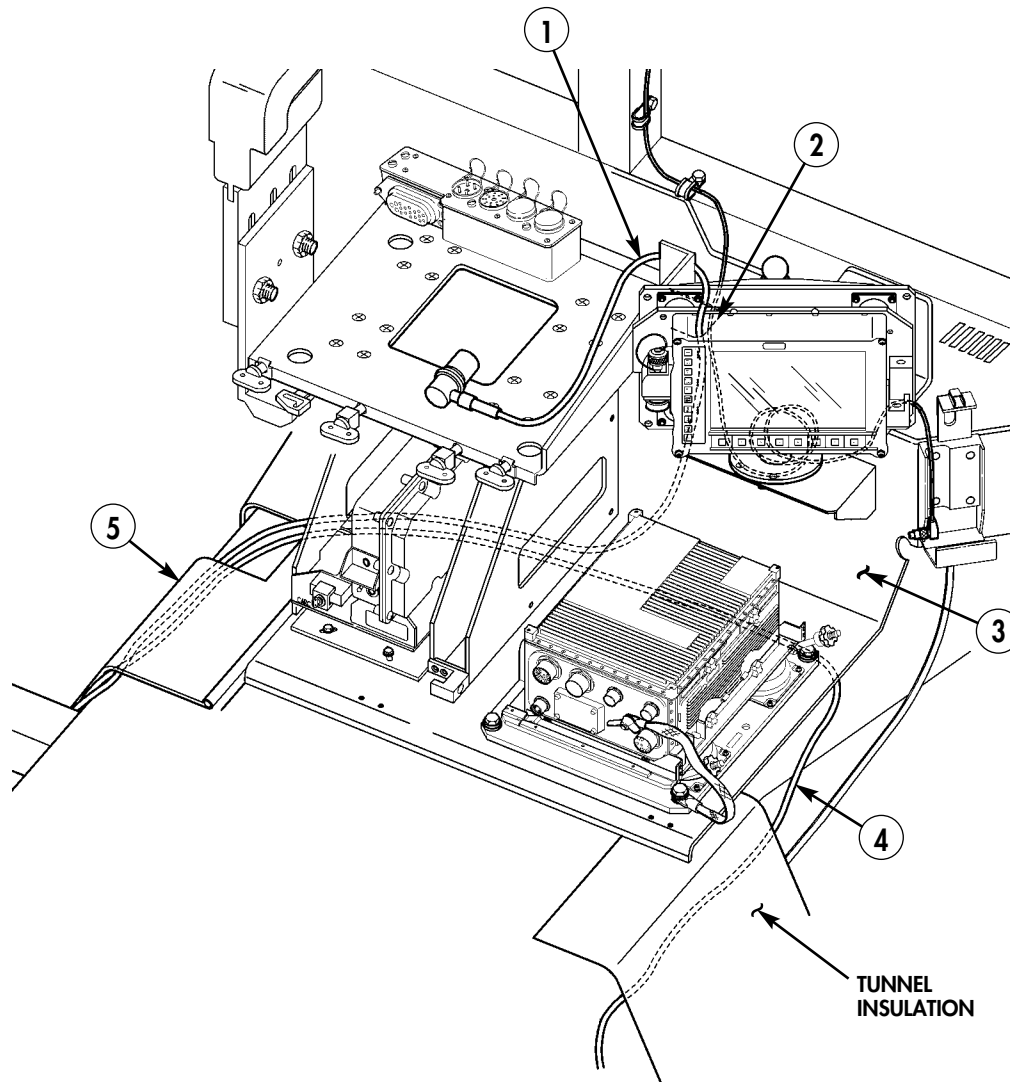

1. INC-EPUU CABLE – A3279383-3 – QTY. 1  
4. EPLRS POWER CABLE – A3004939 – QTY. 1

Figure 5-110.

**NOTE**

Perform step 39-4 for vehicles with left rear cab enclosure panel only.

- 39-4.** Cut 2x2 in. section (13) from left rear cab enclosure panel (11). Install grommet (12). Reinstall cab enclosure panel (11). (Refer to TM 9-2320-280-20.)
- 39-5.** Locate, mark, and drill three 0.147-in. holes (8) along tunnel edge (9).
- 39-6.** Route INC-EPUU cable (1) and power cable (4) rearward under left-side B-beam (10) and along tunnel edge (9).
- 39-7.** Route INC-EPUU cable (1) and power cable (4) rearward along tunnel edge (9) and secure with three clamps (7) and self-tapping screws (6).



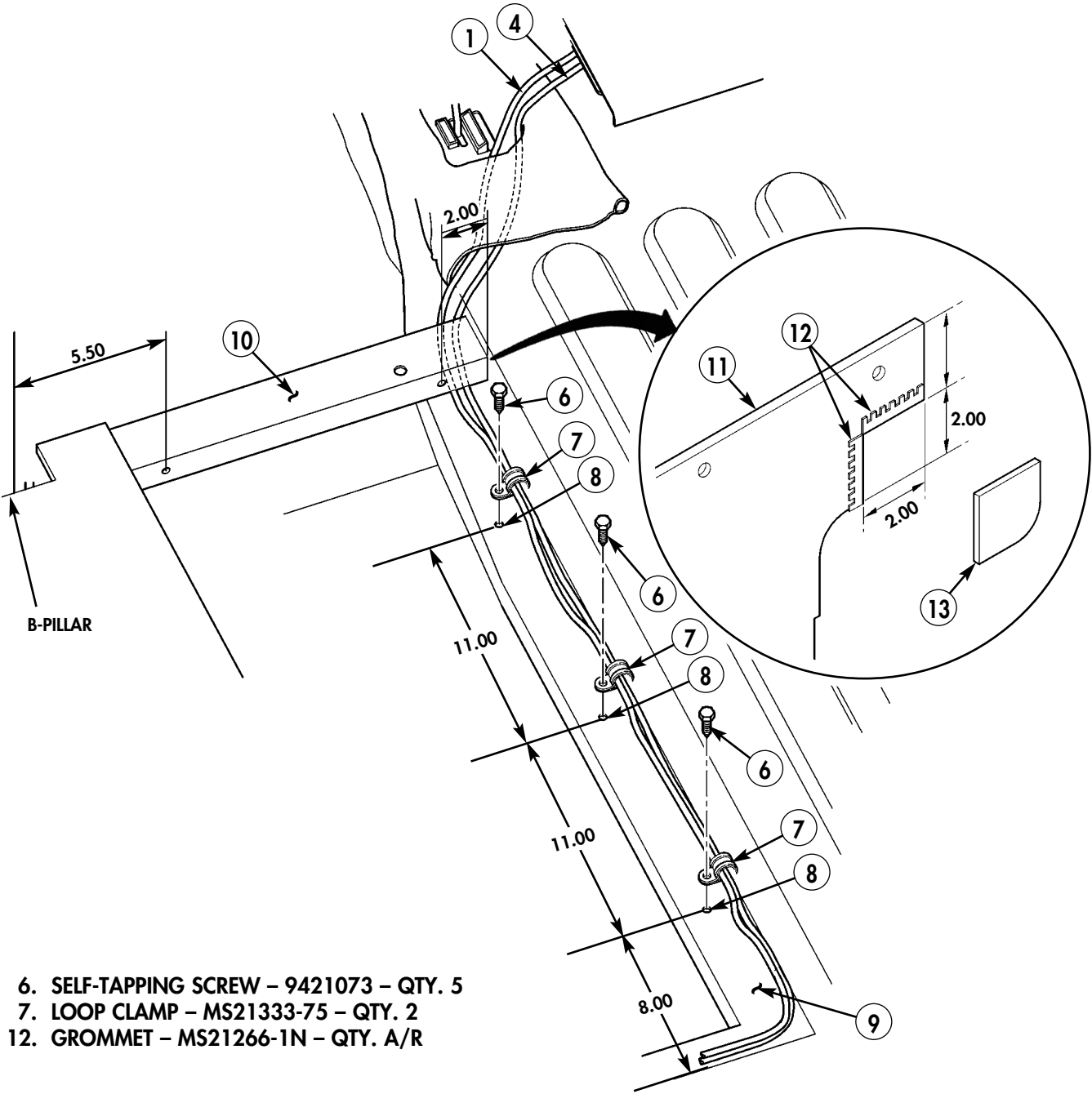
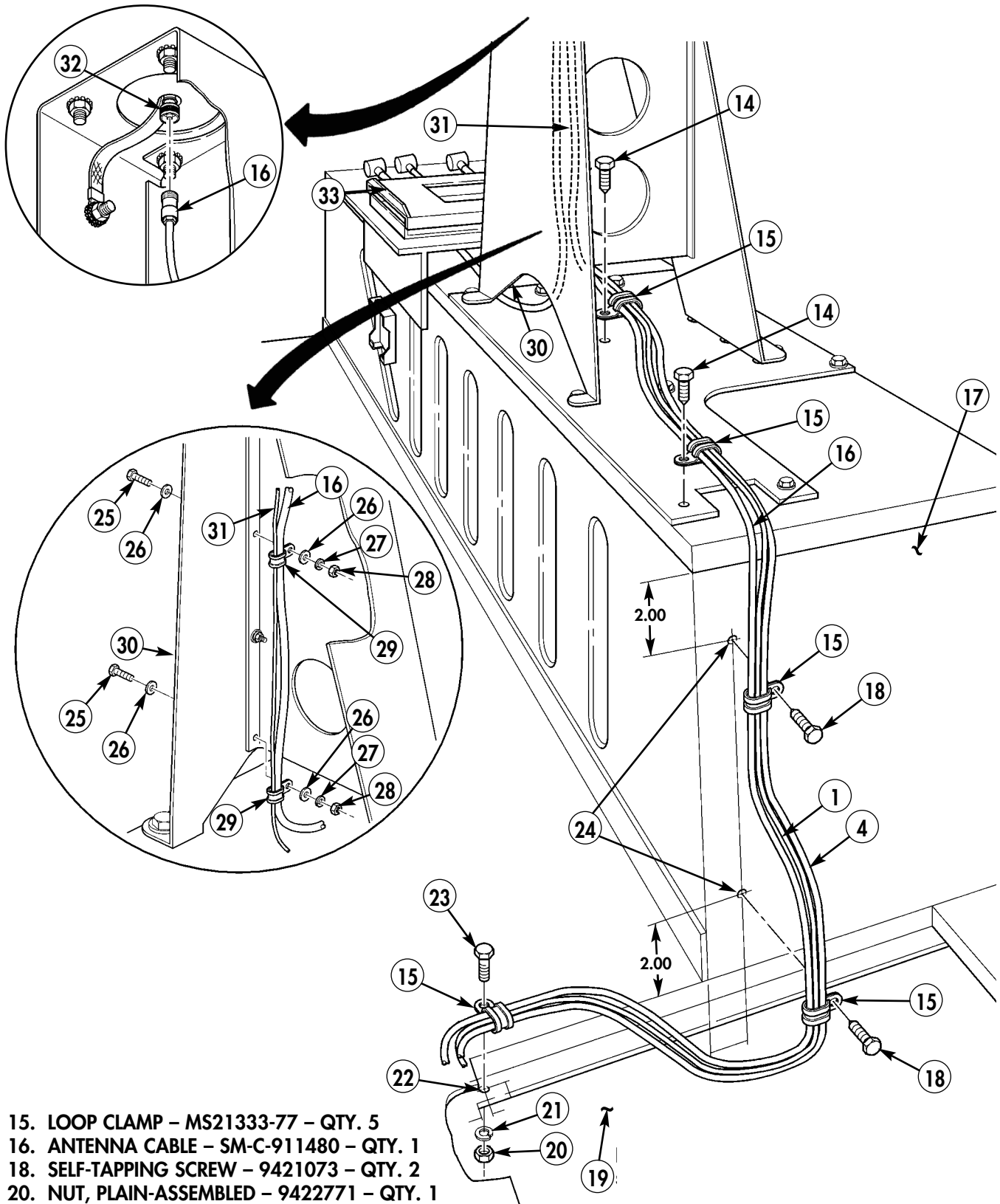

Figure 5-111.

- 39-8.** Locate, mark, and drill one 0.225-in. hole (22) in inboard corner on rear inside lip of left rear seat back support (19).
- 39-9.** Locate, mark, and drill two 0.147-in. holes (24) in front face of left rear wheelwell (17).
- 39-10.** Route EPLRS cables (16), (1), and (4) along rear perimeter of left rear seat back support (19), up front face of left rear wheelwell (17), and under antenna base (30).
- 39-11.** Route NTDR antenna cable (31) down antenna base (30) to left rear wheelwell (17).
- 39-12.** Route NTDR antenna cable (31) along top of left rear wheelwell (17), and down front face of left rear wheelwell (17).
- 39-13.** Route NTDR antenna cable (31) along left rear seat back support to multi-net rack.
- 39-14.** Secure cables (16), (1), (4), and (31) to left rear wheelwell (17) with screw (23), lockwasher (21), nut (20), two self-tapping screws (18), two existing screws (14), and five loop clamps (15).
- 39-15.** Route cables (1) and (4) to EPLRS mount (33)
- 39-16.** Secure antenna cables (16) and (31) to antenna base (30) with existing loop clamps (29), screws (25), washers (26), lockwashers (27), and nuts (28).
- 39-17.** Connect EPLRS antenna cable (16) to EPLRS antenna (32).
- 39-18.** Connect NTDR antenna cable (31) to NTDR antenna.
- 39-19.** Take slack out of EPLRS cables (16), (1), and (4) and store under EPLRS mount (33).
- 39-20.** Take slack out of NTDR antenna cable (31) and store under NTDR mount.
- 39-21.** Tighten all screws and nuts on all clamps.
- 39-22.** Secure right-side tunnel insulation. (Refer to TM 9-2320-280-20.)



- 15. LOOP CLAMP - MS21333-77 - QTY. 5
- 16. ANTENNA CABLE - SM-C-911480 - QTY. 1
- 18. SELF-TAPPING SCREW - 9421073 - QTY. 2
- 20. NUT, PLAIN-ASSEMBLED - 9422771 - QTY. 1
- 21. LOCKWASHER - MS35338-43 - QTY. 1
- 23. SCREW - MS35206-265 - QTY. 1
- 29. LOOP CLAMP - MS21333-102 - QTY. 2

Figure 5-112.  
5-99

## Section XL. C4ISR POWER CABLES INSTALLATION

### NOTE

- Use aluminum flat bar as template to locate and mark hole position.
- Use No. 30 drill bit to drill holes in battery box.

**40-1.** Drill five 0.129-in. to 0.133-in. diameter holes (4) in lip of battery box (3).

**40-2.** Install rubber sheet (1) and aluminum flat bar (5) on battery box (3) with five rivets (2).

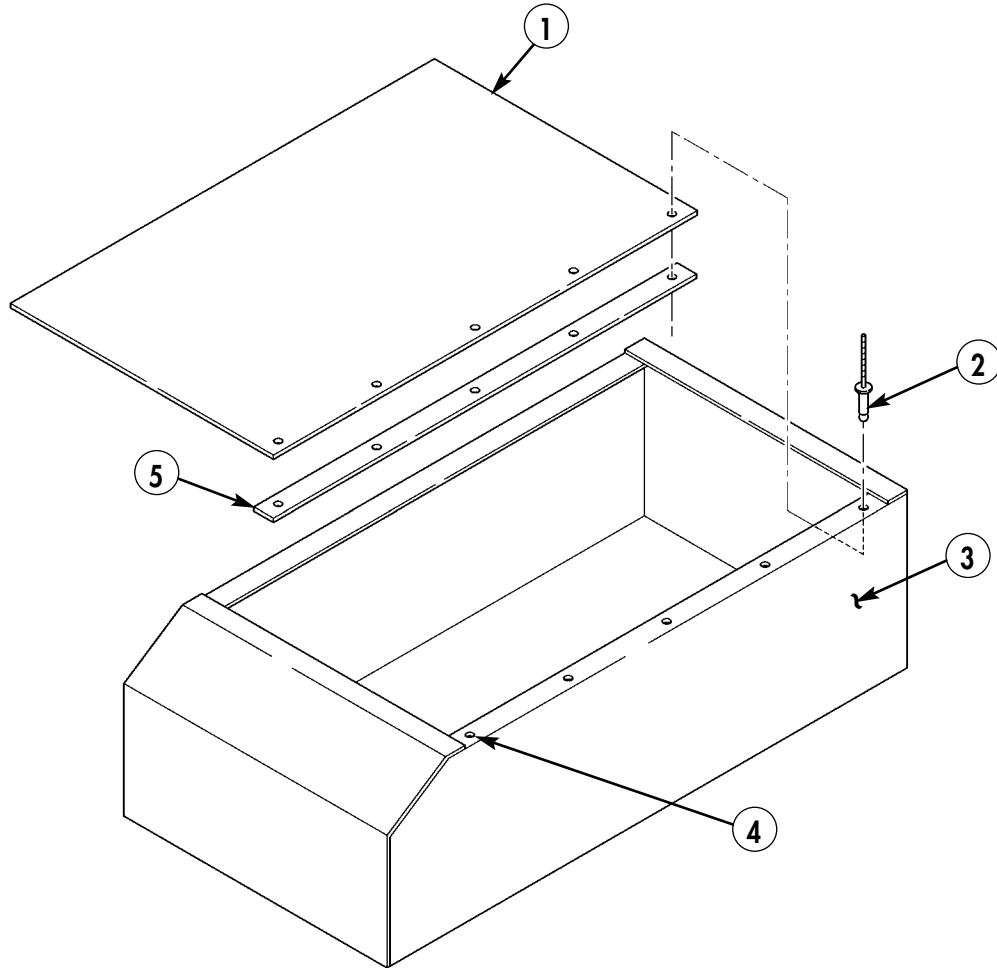

- 1. RUBBER SHEET – 03A016D-1 – QTY. 1
- 2. RIVET – AB4-5A – QTY. 5
- 5. ALUMINUM FLAT BAR – 03A016D-2 – QTY. 1

*Figure 5-113.*

40-3. Position terminal board in battery box (3). Using terminal board as template, locate, mark, and drill three 0.125-in. diameter holes (6) in battery box (3).

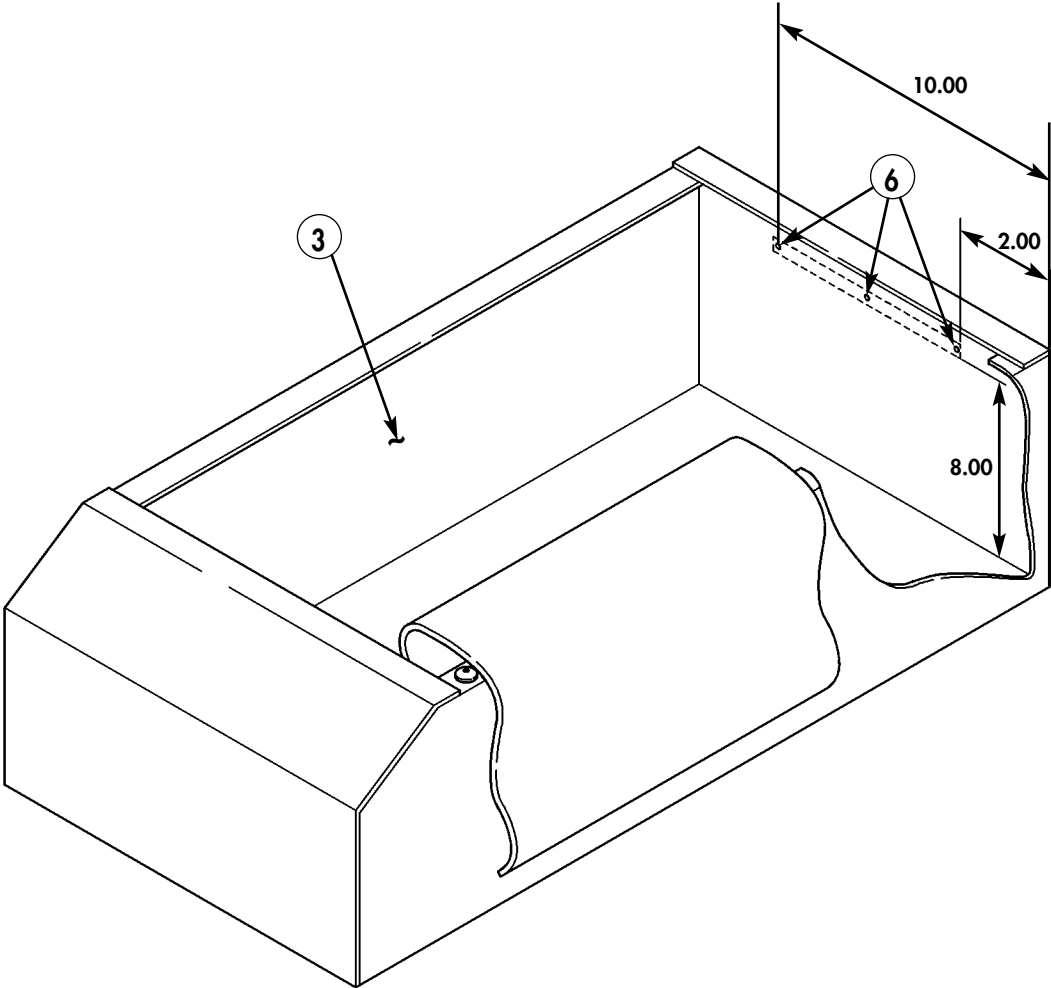
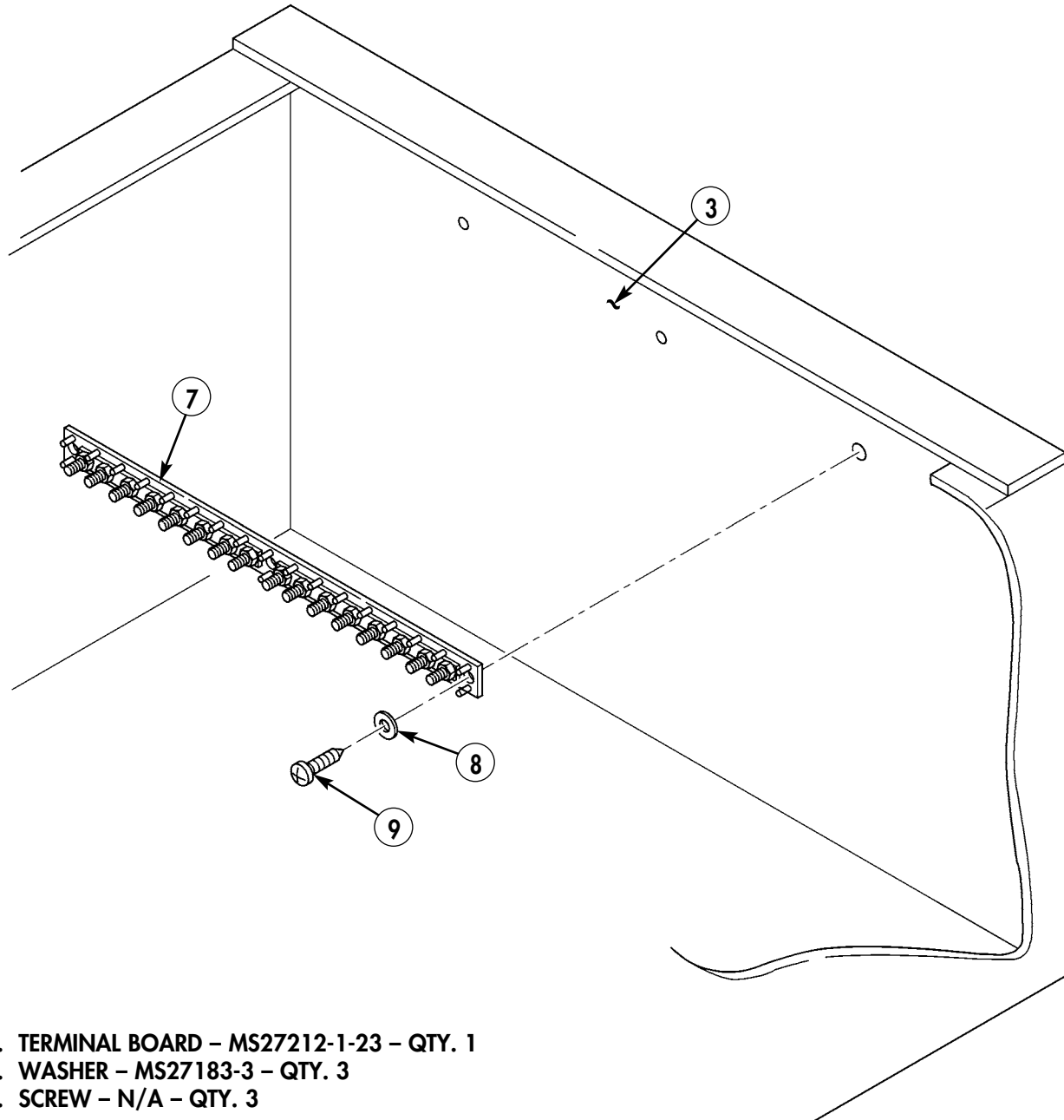

Figure 5-114.

40-4. Install terminal board (7) in battery box (3) with three screws (9) and washers (8).



- 7. TERMINAL BOARD – MS27212-1-23 – QTY. 1
- 8. WASHER – MS27183-3 – QTY. 3
- 9. SCREW – N/A – QTY. 3

Figure 5-115.

- 40-5. Locate, mark, and drill one 0.188-in. diameter hole (11) in battery box (3).
- 40-6. Using shunt as template, locate, mark, and drill one 0.188-in. diameter hole (10) in battery box (3).

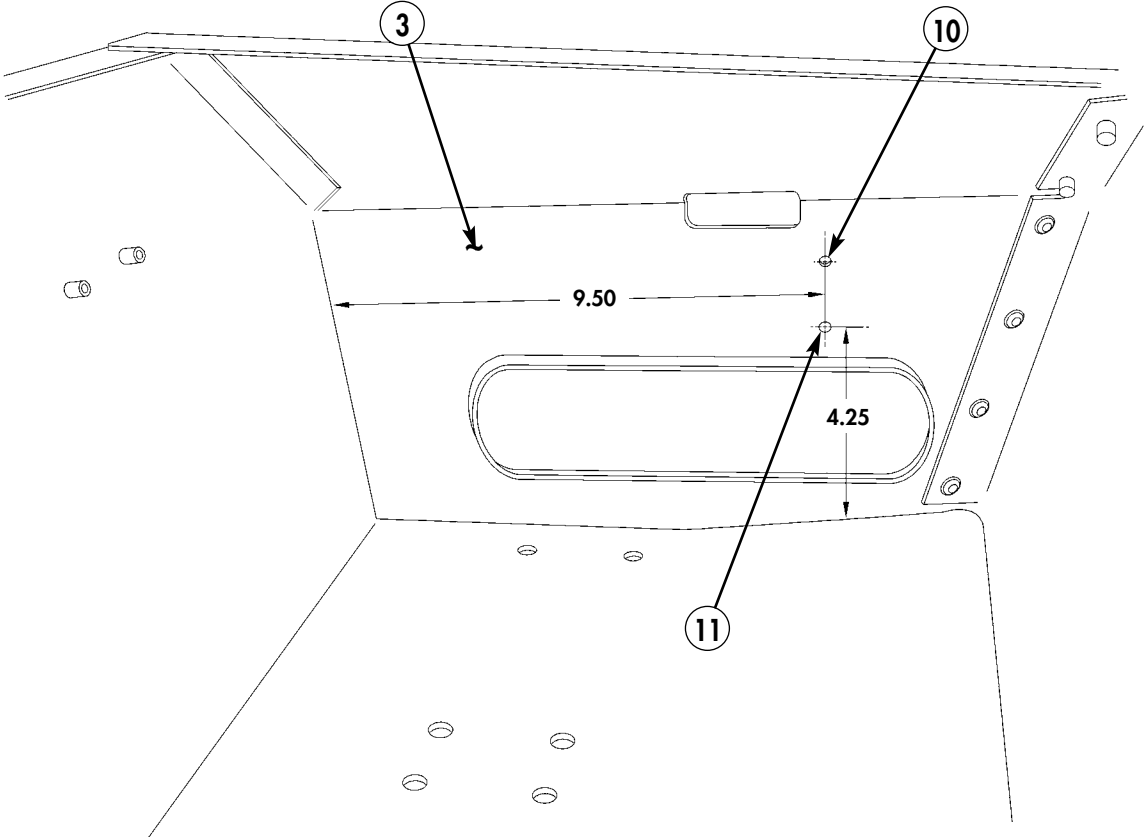
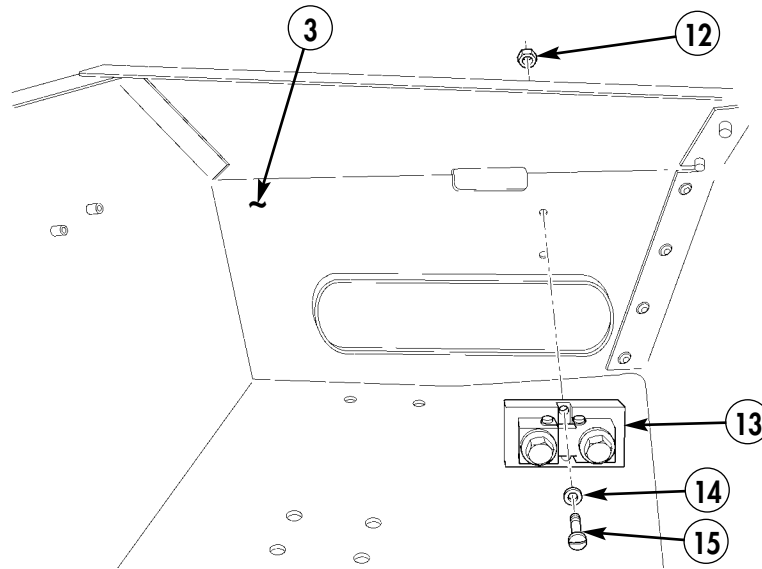

Figure 5-116.

40-7. Install shunt (13) in battery box (3) with two screws (15), washers (14), and locknuts (12).



- 12. LOCKNUT – MS21044-NO8 – QTY. 2
- 13. SHUNT – PKMM 000-013 – QTY. 1
- 14. WASHER – MS27183-41 – QTY. 2
- 15. SCREW – MS35206-247 – QTY. 2

Figure 5-117.

40-8. Locate, mark, and drill one 0.281-in. diameter hole (16) in battery box (3).

40-9. Using solenoid as template, locate, mark, and drill one 0.281-in. diameter hole (17) in battery box (3).

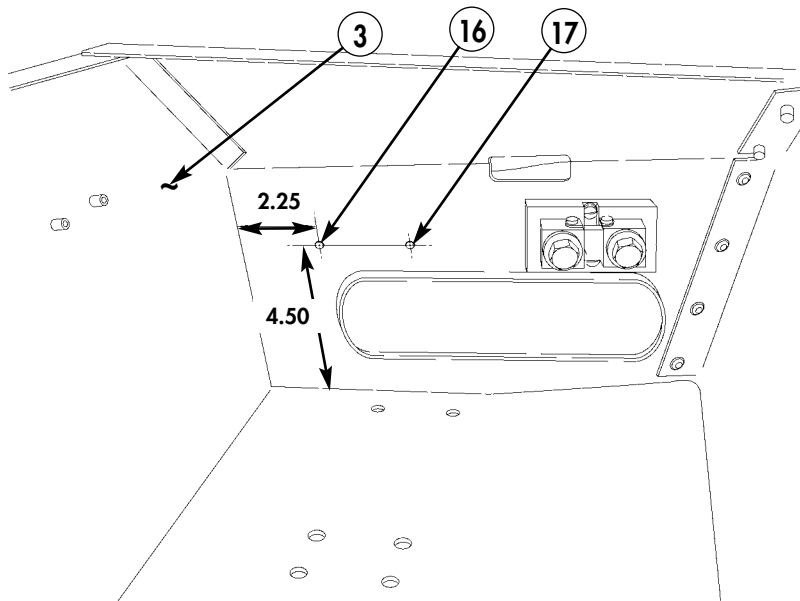
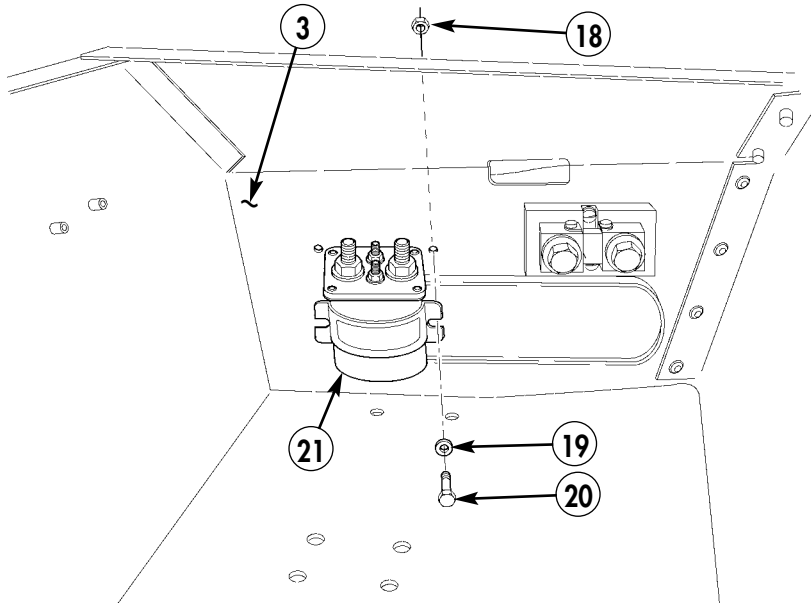

Figure 5-118.



40-10. Install solenoid (21) in battery box (3) with two capscrews (20), washers (19), and locknuts (18).



- 18. LOCKNUT - MS17829-4C - QTY. 2
- 19. WASHER - 2436161 - QTY. 2
- 20. CAPSCREW - B1821BH025C075N - QTY. 2
- 21. SOLENOID - 586-905 - QTY. 1

Figure 5-119.

40-11. Drill one 2.50-in. diameter hole (23) in battery box (3).  
40-12. Cut grommet material (22) to length and install in hole (23) of battery box (3).

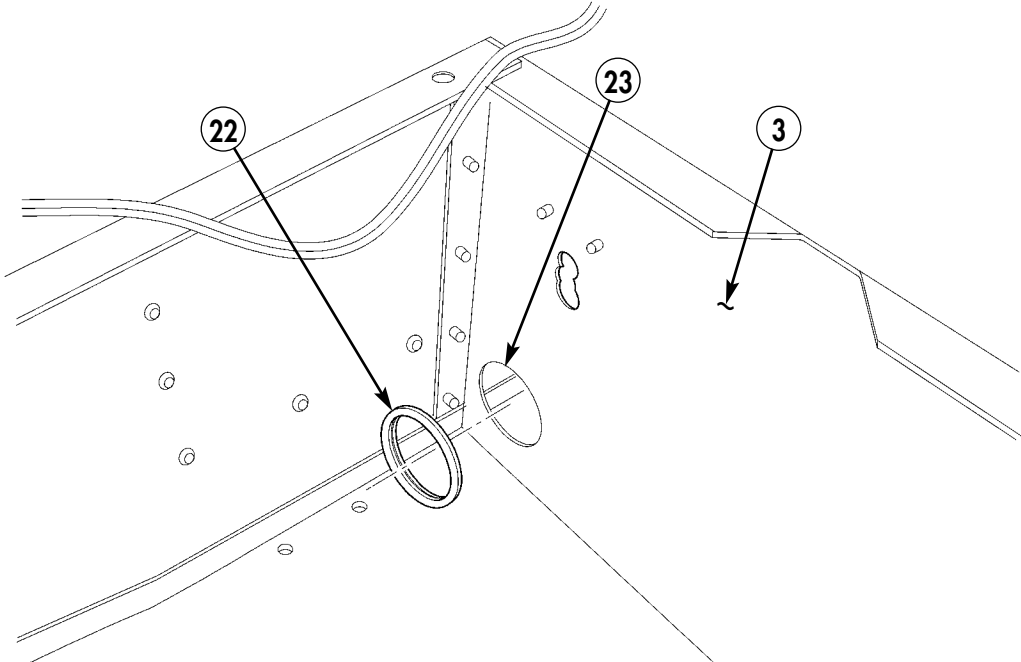

- 22. GROMMET MATERIAL - 12341628 - QTY. A/R

Figure 5-120.

40-13. Locate, mark, and drill nine 0.188-in. diameter holes (24) in battery box (3).

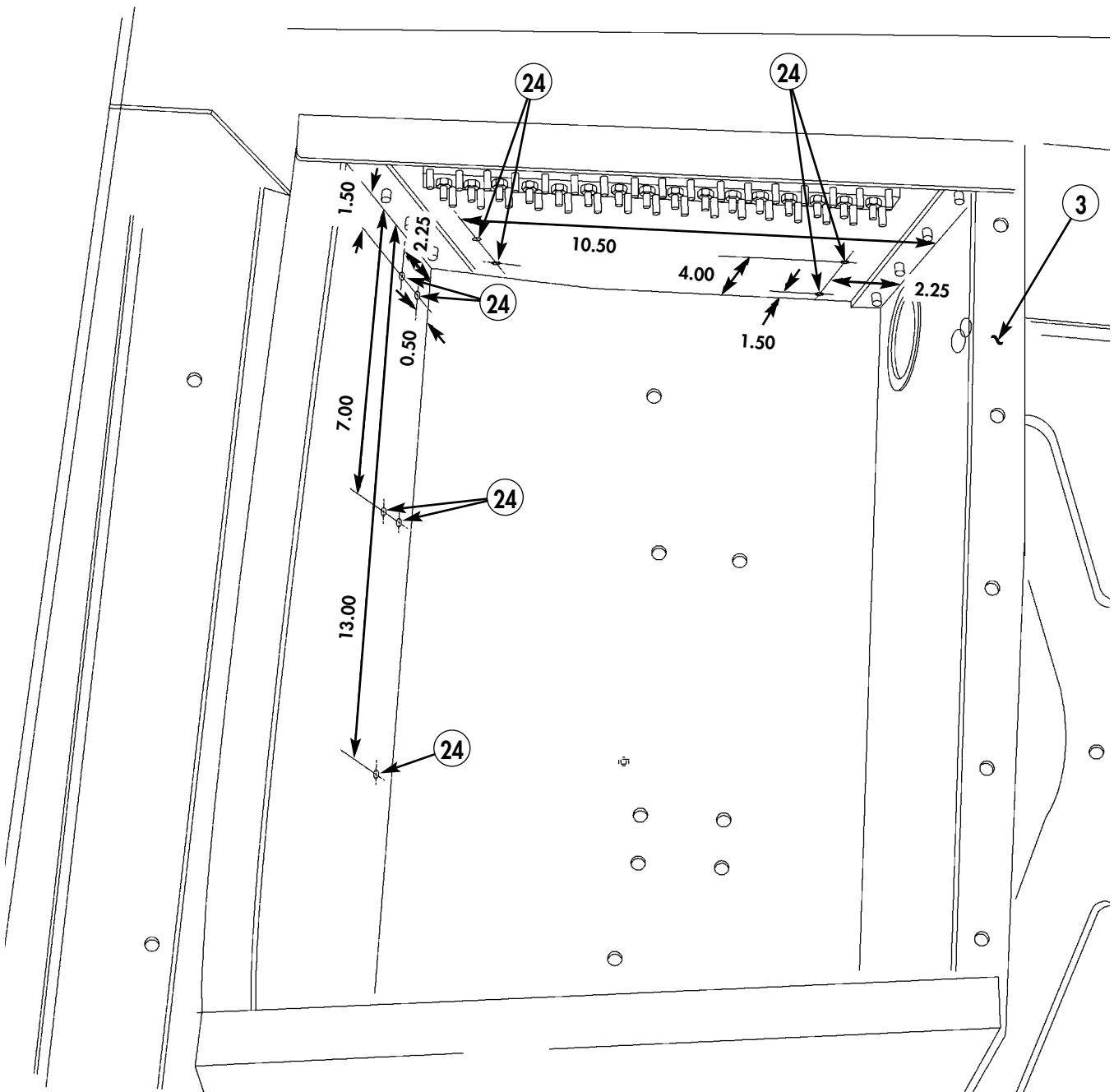
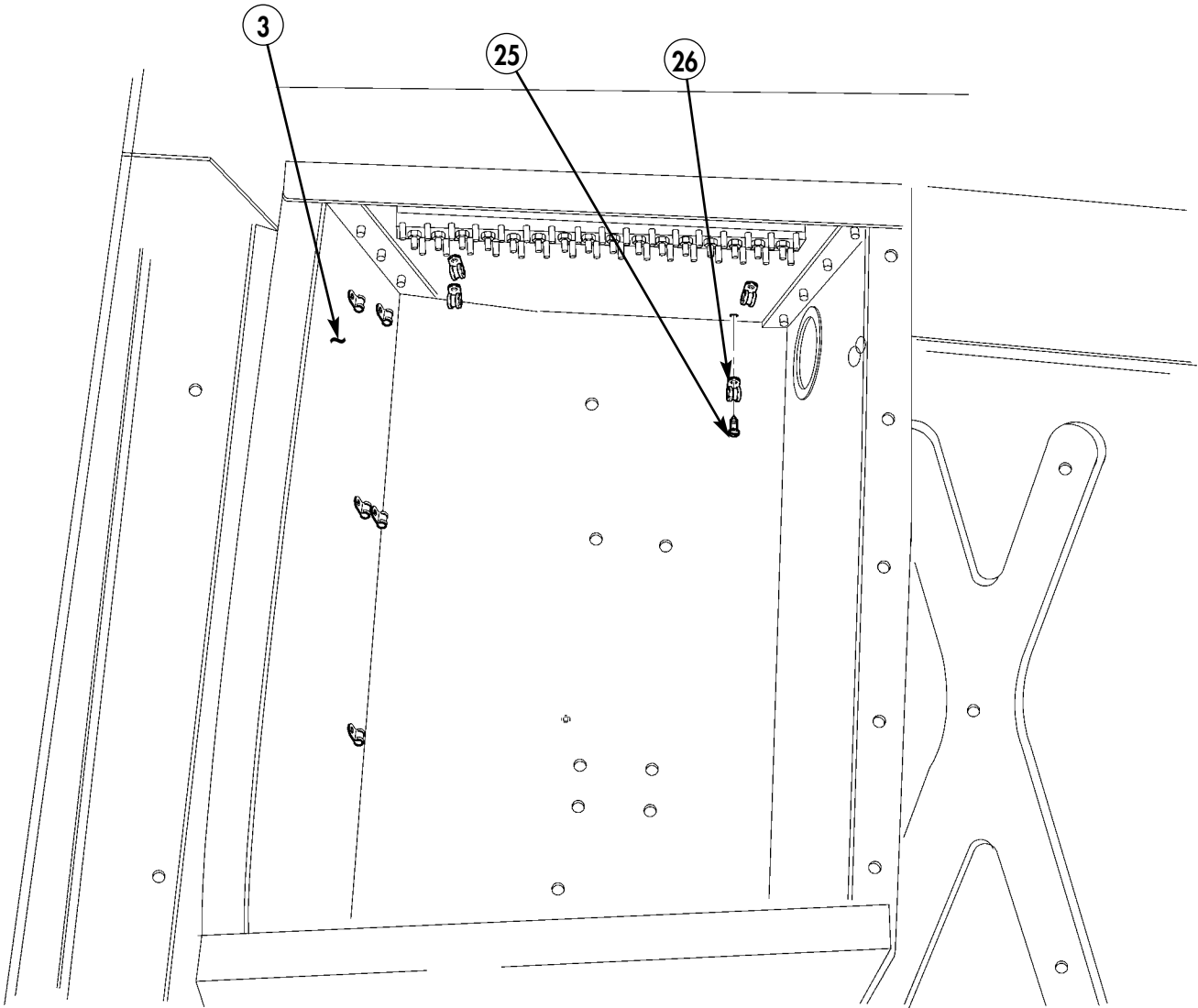

Figure 5-121.

40-14. Install nine clamps (26) in battery box (3) with self-tapping screws (25).



- 25. SELF-TAPPING SCREW – 9421073 – QTY. 9
- 26. LOOP CLAMP – MS21333-65 – QTY. 9

Figure 5-122.

40-15. Locate, mark, and drill two 0.188-in. diameter holes (28) on top of tunnel (27).

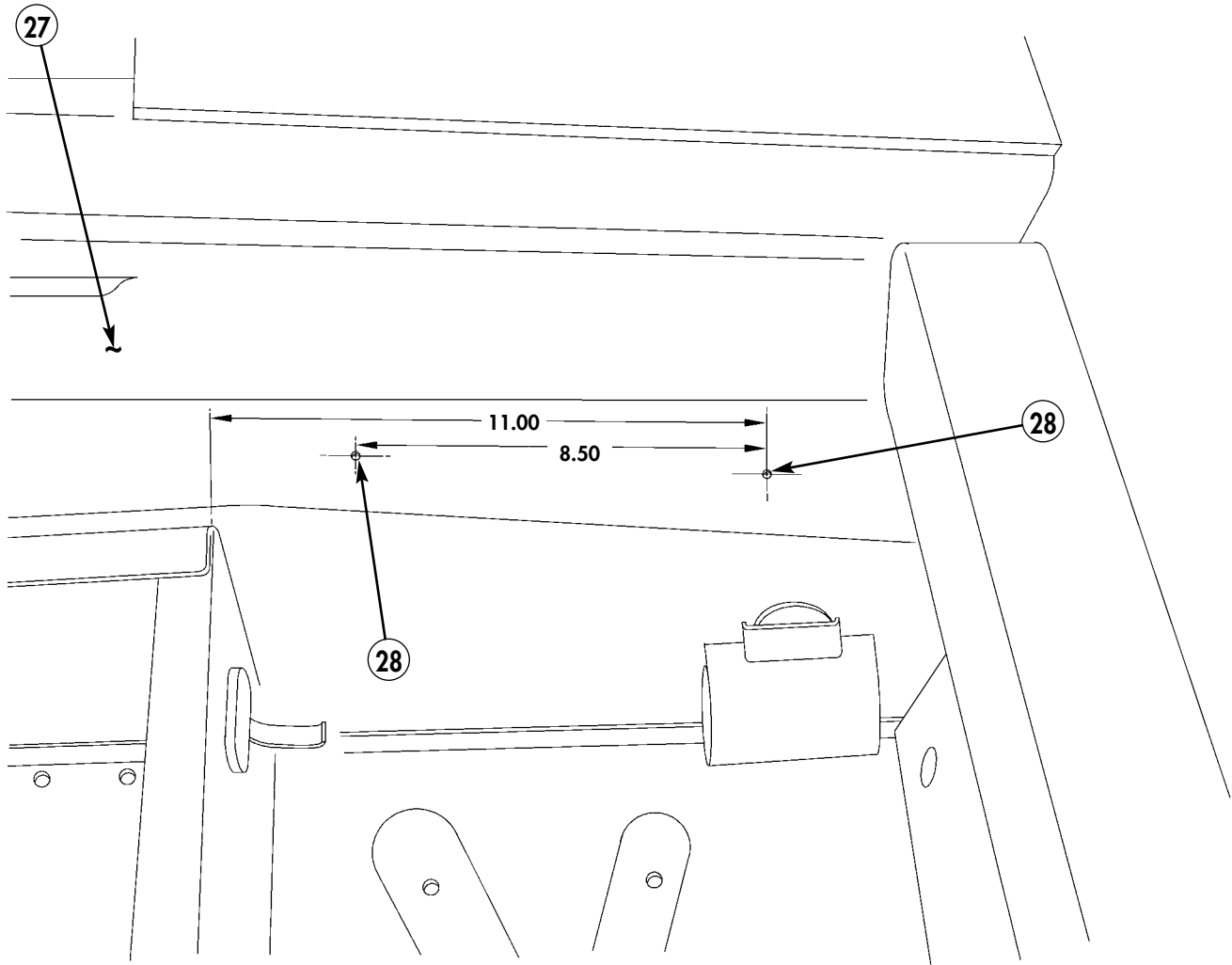

Figure 5-123.

40-16. Locate, mark, and drill two 0.188-in. diameter holes (29) in side of tunnel (27).

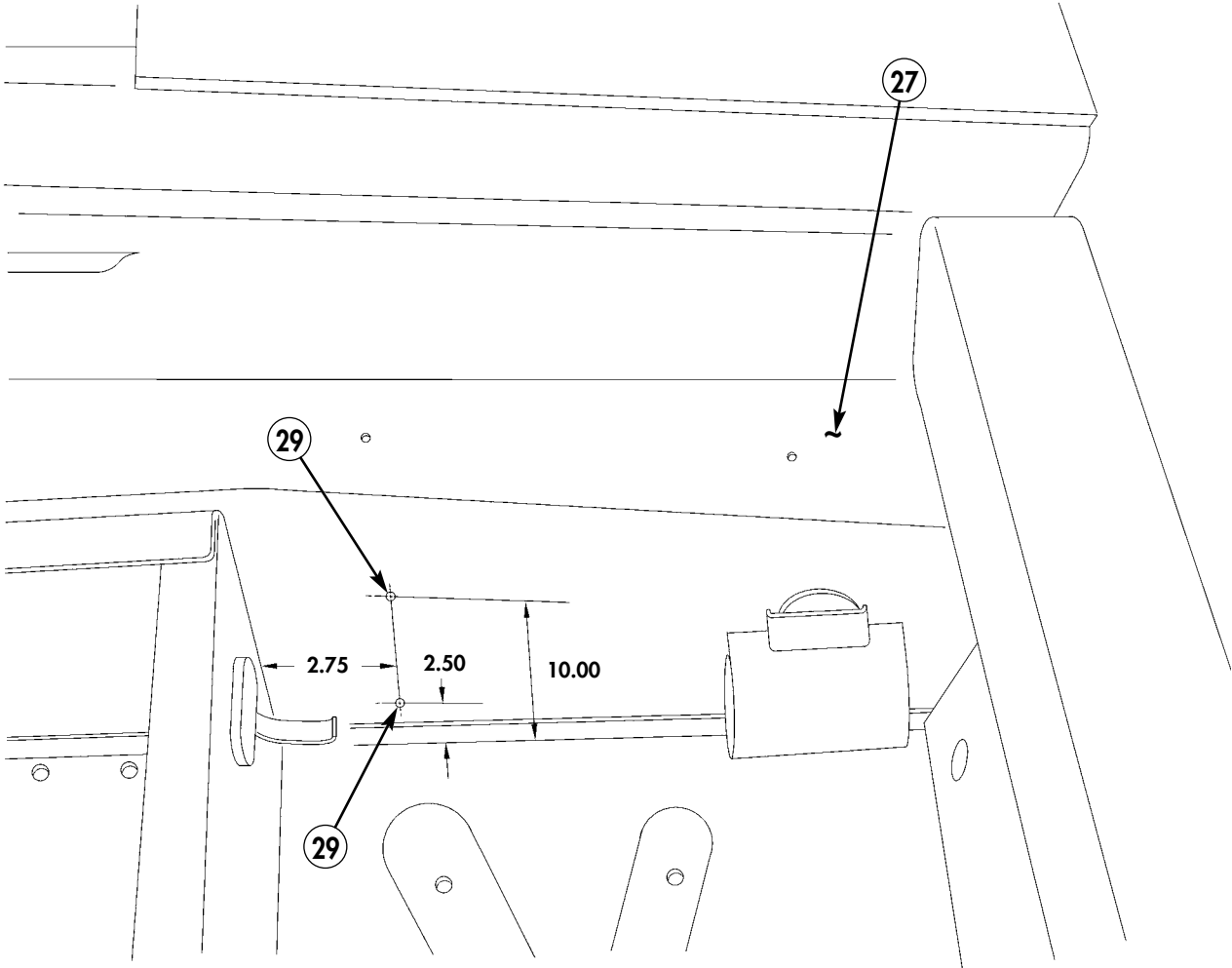
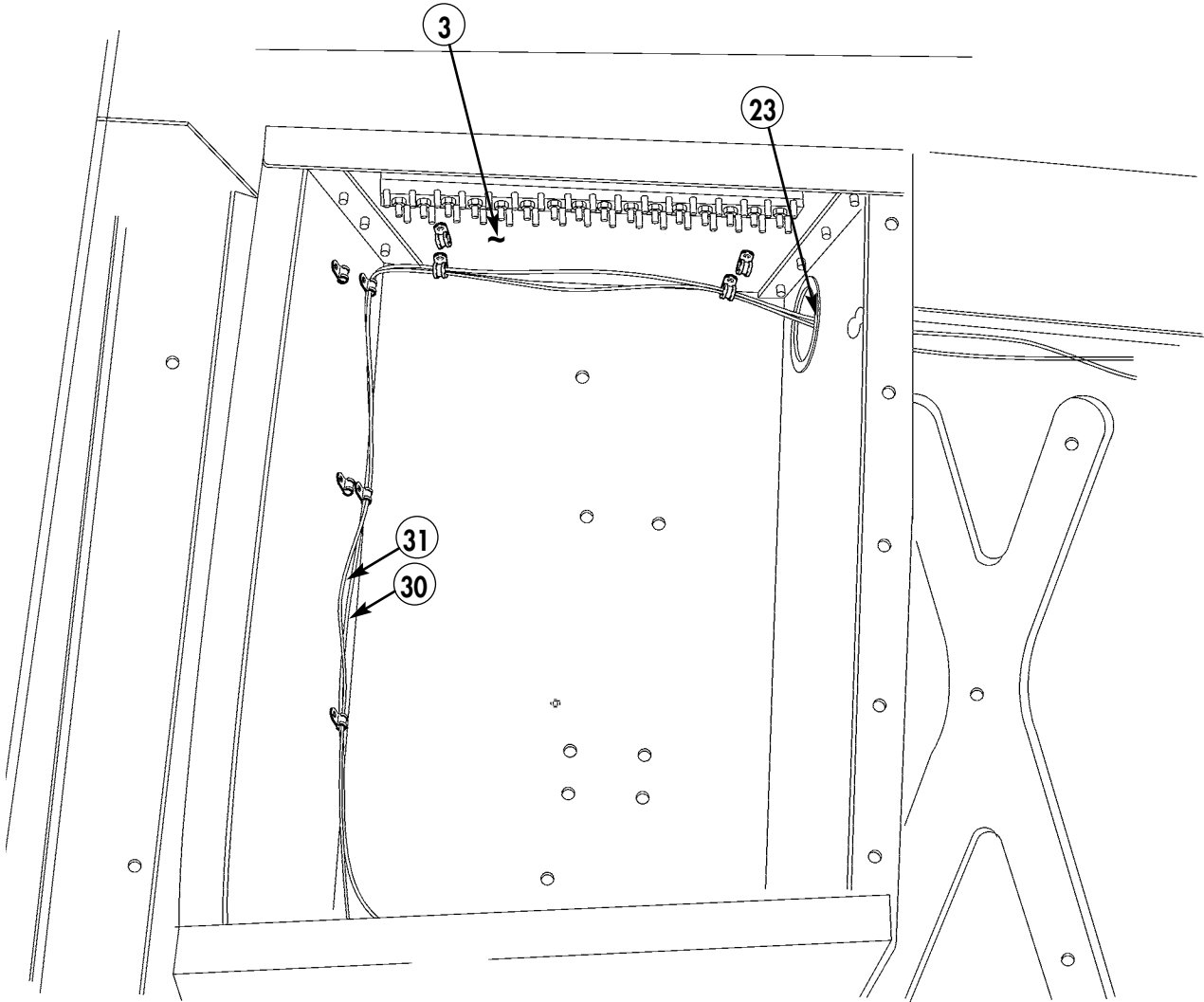

Figure 5-124.

**NOTE**

Do not connect cables to solenoid and shunt at this time.

**40-17.** Route cables (30) and (31) from solenoid and shunt through battery box (3) and hole (23).



**30. CABLE (BATTERY TO SOLENOID) – RCSK-19637 – QTY. 1**

**31. CABLE (BATTERY TO SHUNT) – RCSK-19638 – QTY. 1**

*Figure 5-125.*

**40-18.** Route cables (30) and (31) along tunnel (27), through hole (33) in front battery box (34), and secure with clamps (32) and self-tapping screws (25).

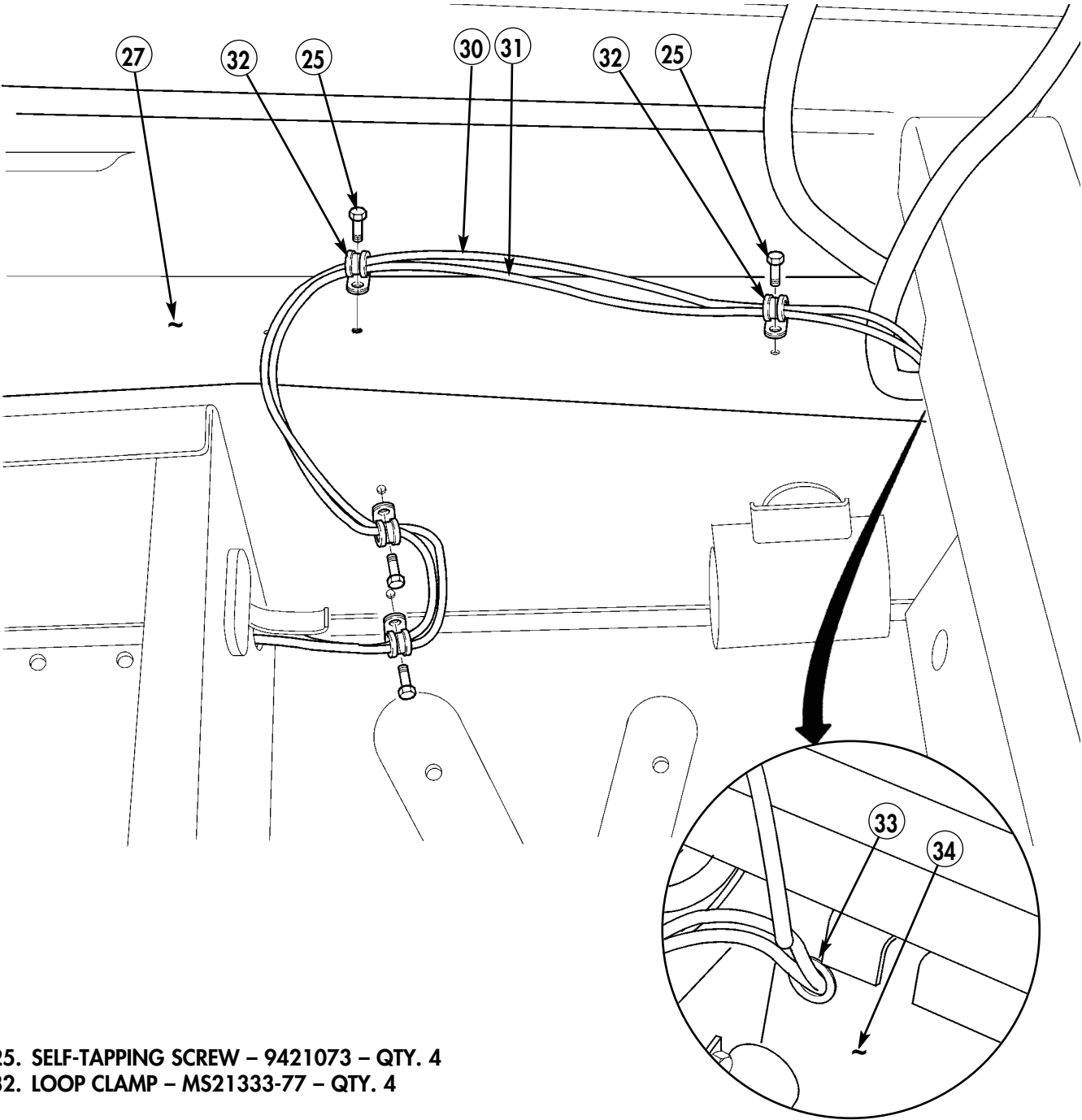

- 25. SELF-TAPPING SCREW – 9421073 – QTY. 4
- 32. LOOP CLAMP – MS21333-77 – QTY. 4

Figure 5-126.

**40-19.** Connect battery-to-shunt cable (31) and battery-to-solenoid cable (30) to front batteries (36) with existing nut (35).

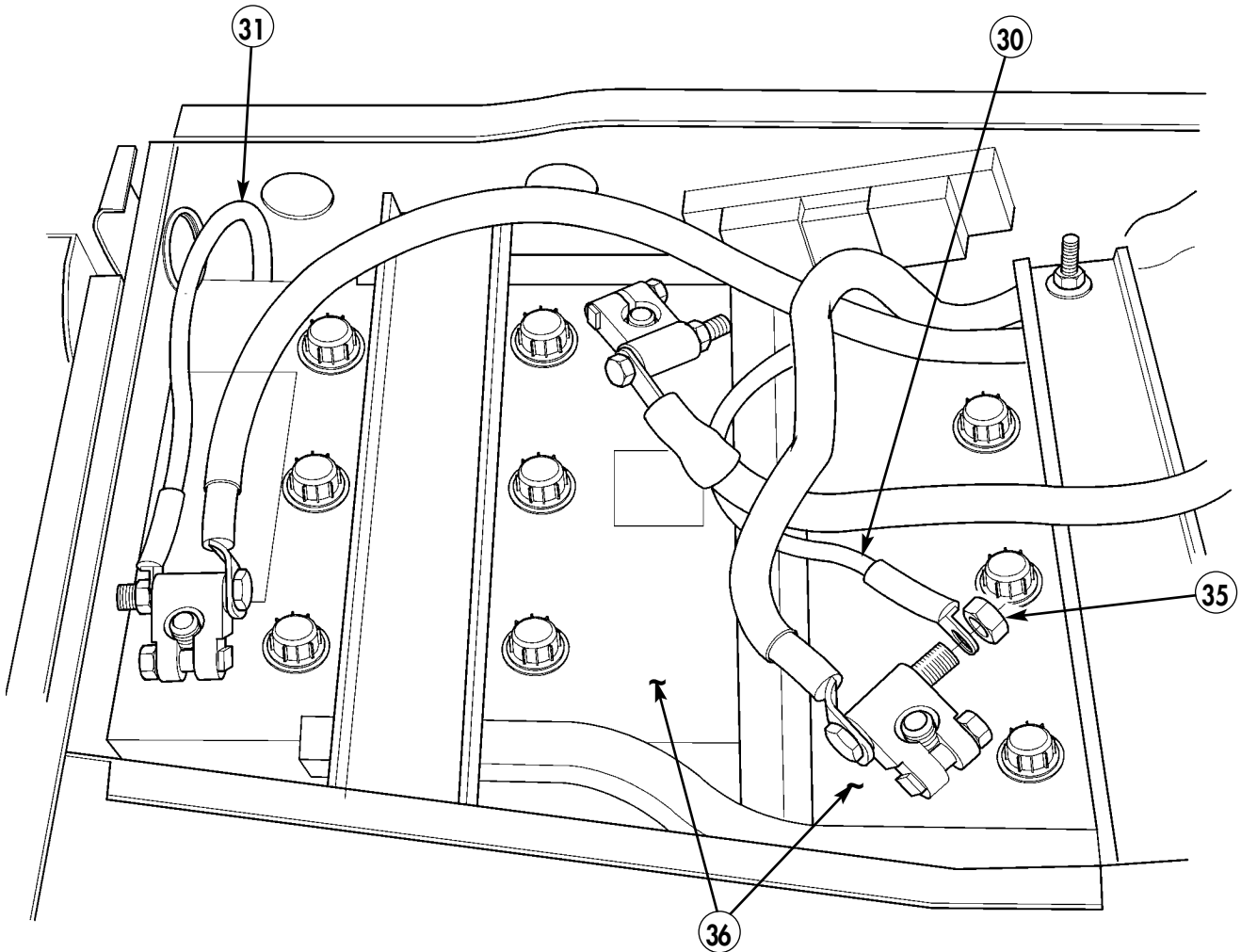

*Figure 5-127.*



- 40-20.** Using battery support plate (37) as template, locate, mark, and drill ten 0.129-in. to 0.133-in. diameter holes (41) in vehicle floor (40) and battery box (3).
- 40-21.** Install battery support plate (37) and J-bolts (38) on vehicle and battery box (3) with ten rivets (39).

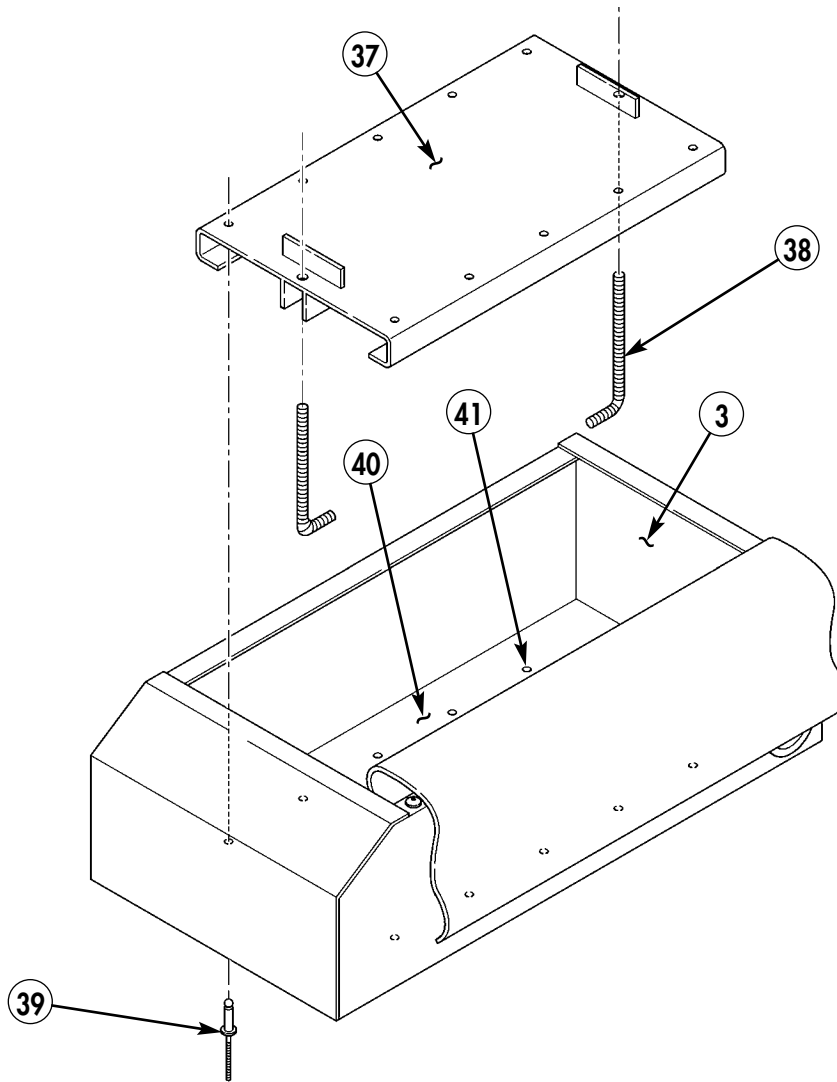

- 37. BATTERY SUPPORT PLATE – 03A0103D-1 – QTY. 1**  
**38. J-BOLT – 03A0103D-3 – QTY. 2**  
**39. RIVET – AB4-5A – QTY. 10**

*Figure 5-128.*

- 40-22. Connect large control cable (44) to charge control box (43).
- 40-23. Route large control cable (44) across lower shelf of multi-net rack (45) to cargo floor (48).
- 40-24. Route large control cable (44) along cargo floor (48) towards battery box.
- 40-25. Route small control cable (47) from battery box, along cargo floor (48), and under tunnel insulation (49).
- 40-26. Secure control cables with two loop clamps (42) and self-tapping screws (25).
- 40-27. Secure small control cable (47) to vehicle with clamp (46) and self-tapping screw (25).

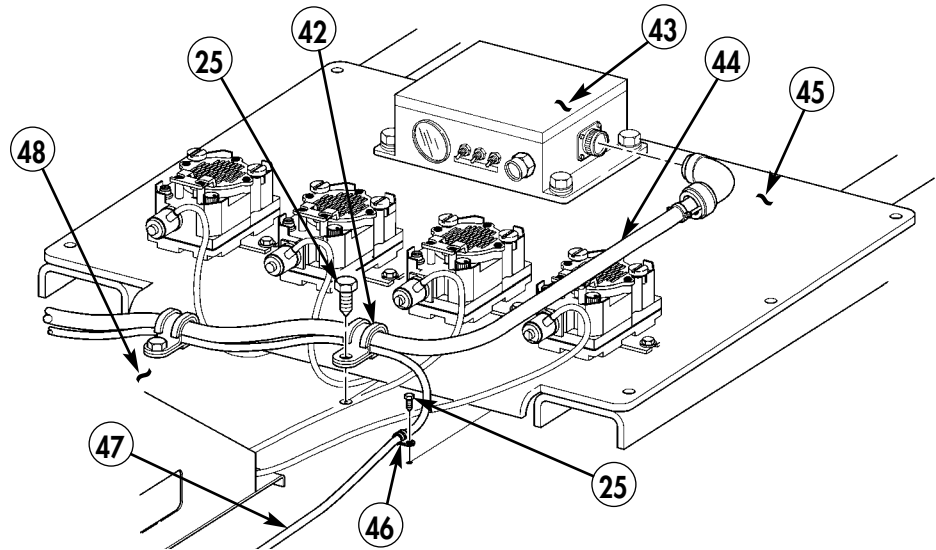

- 25. SELF-TAPPING SCREW – 9421073 – QTY. 3
- 42. LOOP CLAMP – N/A – QTY. 2
- 44. LARGE CONTROL CABLE – 03A0112D – QTY. 1
- 46. LOOP CLAMP – MS21333-71 – QTY. 1

Figure 5-129.

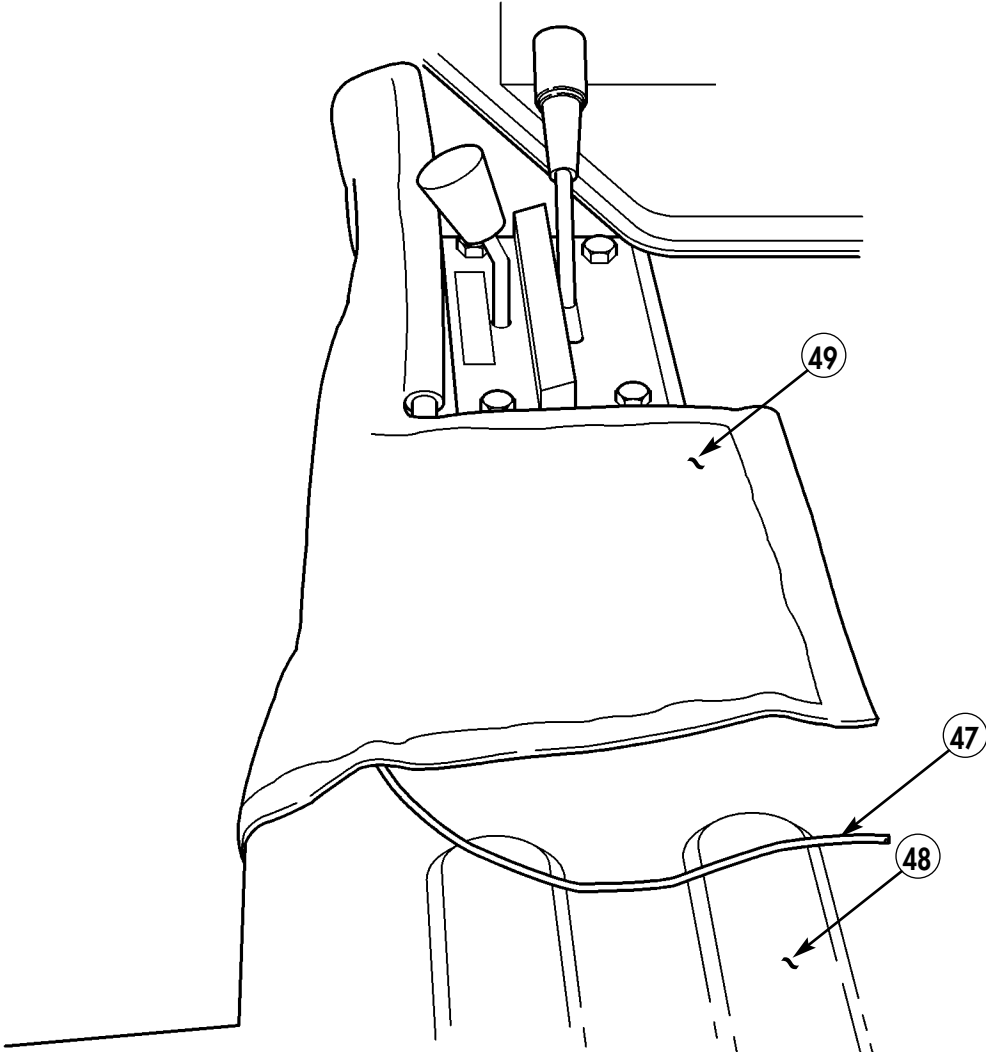
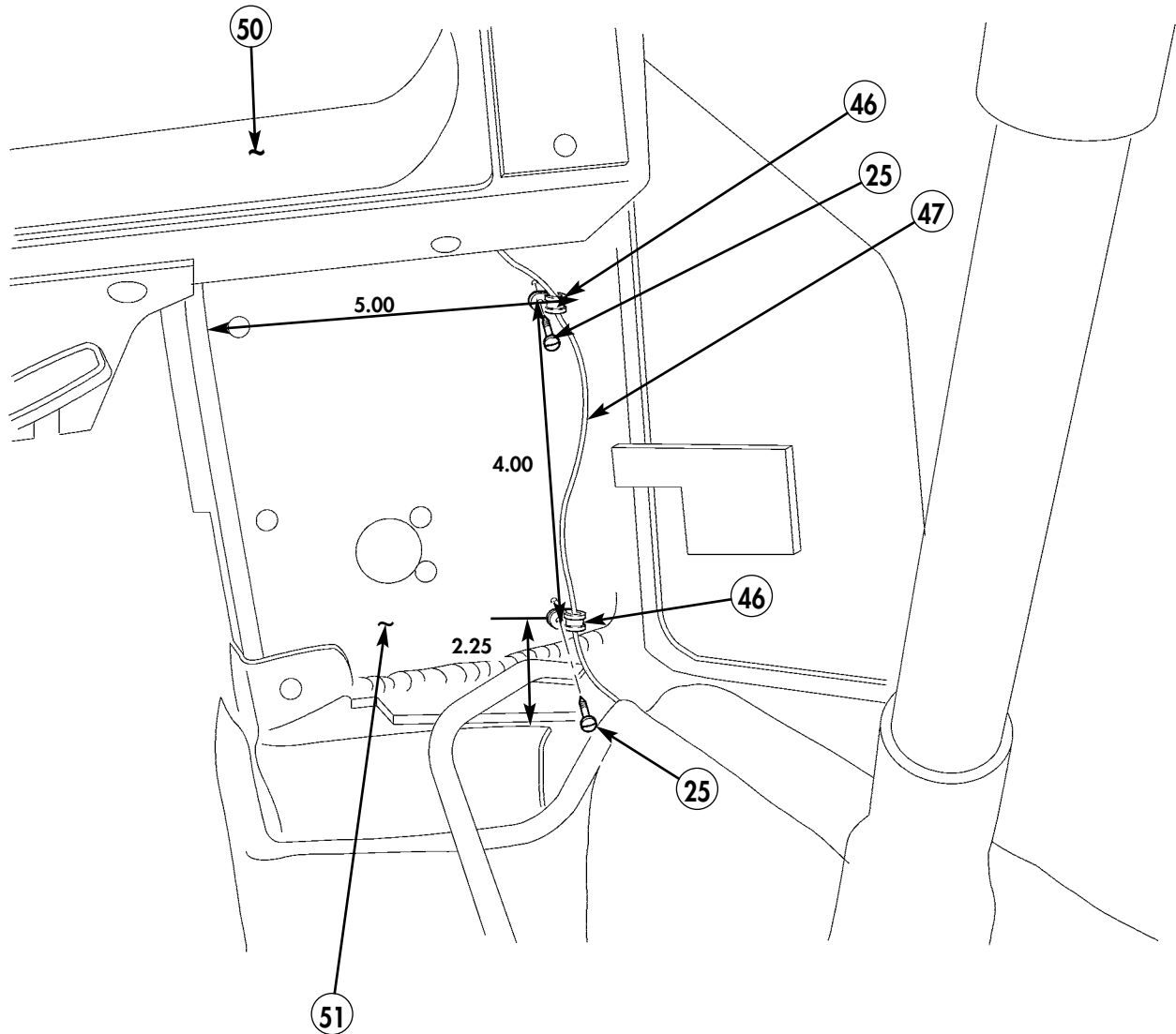

Figure 5-130.

- 40-28. Route small control cable (47) up firewall (51).
- 40-29. Secure small control cable (47) with two clamps (46) and self-tapping screws (25).
- 40-30. Route small control cable (47) under dash panel (50).



- 25. SELF-TAPPING SCREW – 9421073 – QTY. 2
- 46. LOOP CLAMP – MS21333-71 – QTY. 2

Figure 5-131.

- 40-31. Disconnect light switch (54) from harness (55).
- 40-32. Remove four bolts (53) and light switch (54) from dash panel (52).

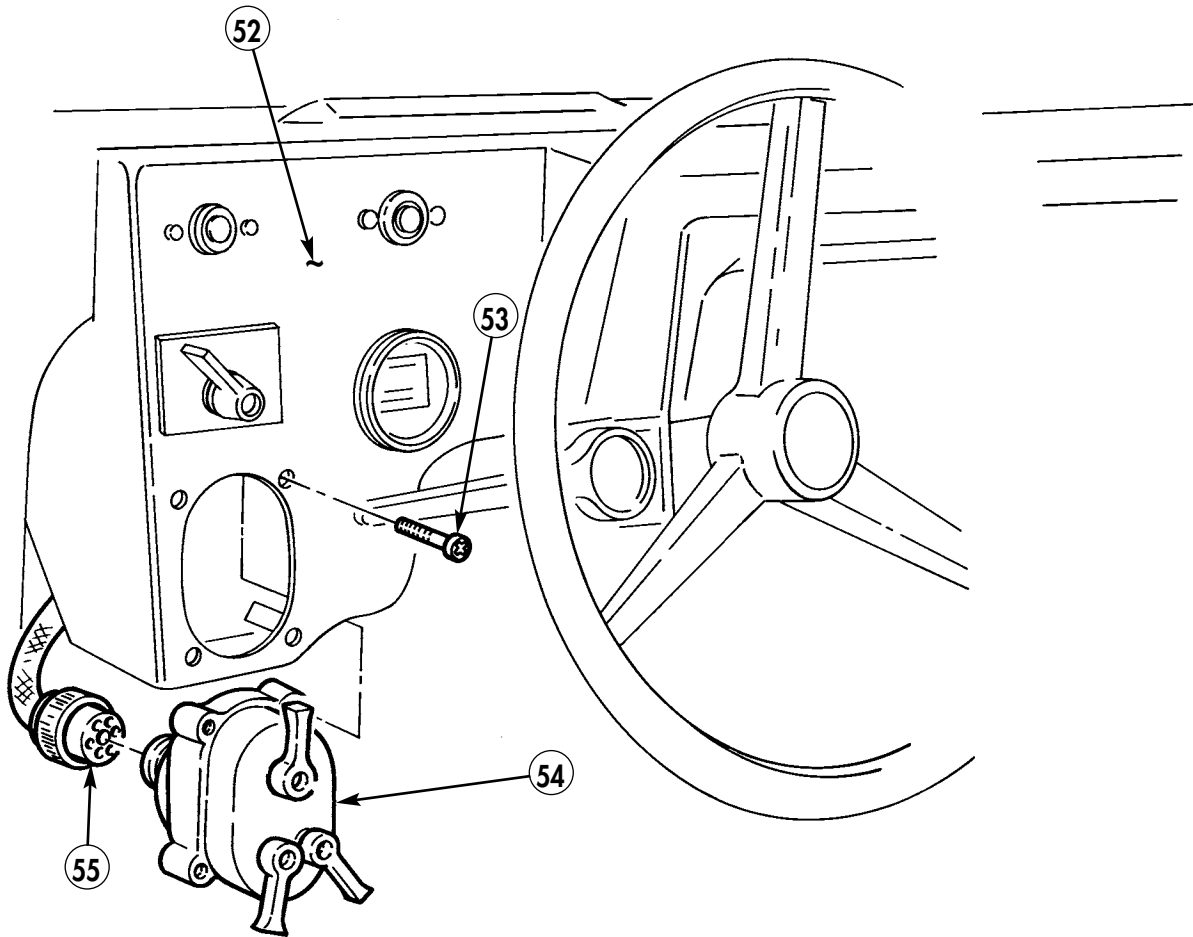

Figure 5-132.

- 40-33. Strip wire insulation from wire 29A (56).
- 40-34. Splice small control cable (47) with wire 29A (56).
- 40-35. Cover splice with electrical tape (57).

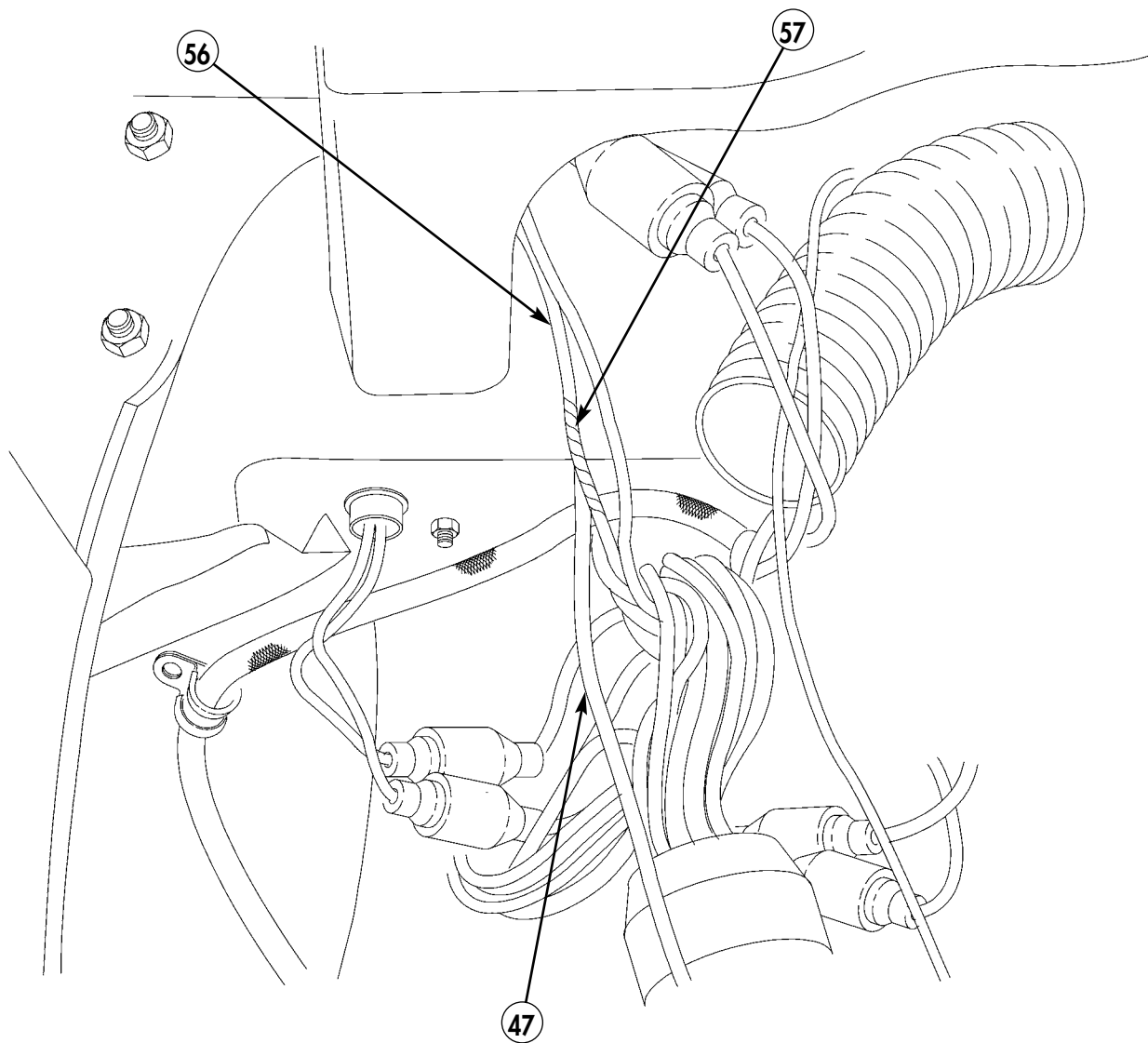

Figure 5-133.

- 40-36. Connect light switch (54) to harness (55).
- 40-37. Install light switch (54) in dash panel (52) with four bolts (53).

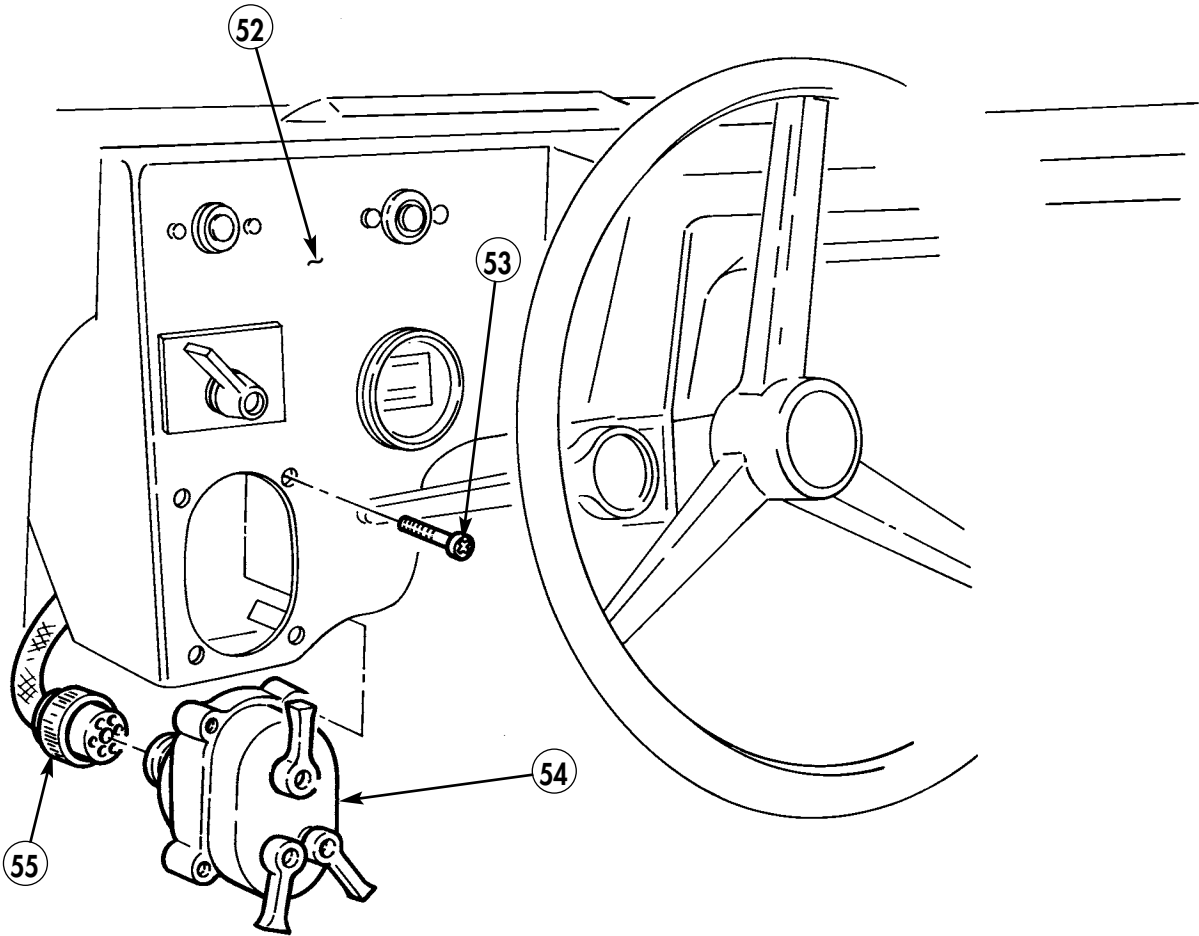
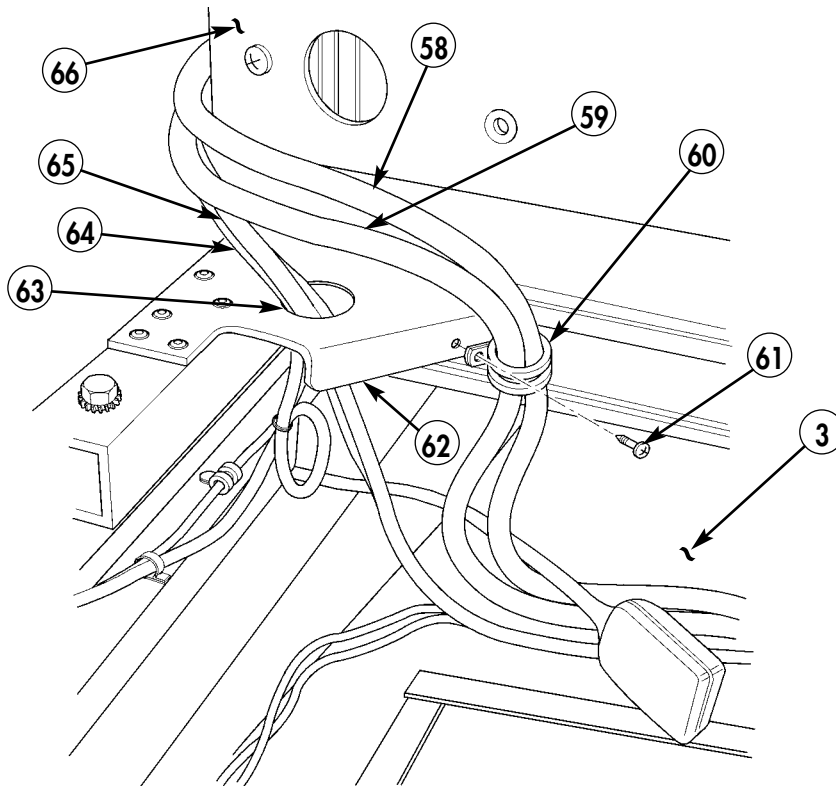

Figure 5-134.

- 40-38. Route NTDR power cable (64) and lower SINCGARS power cable (65) from battery box (3) through hole (63) in frame (62).
- 40-39. Route EPLRS power cable (58) and upper SINCGARS power cable (59) over frame and behind multi-net rack (66). Secure cables (58) and (59) with loop clamp (60) and self-tapping screw (61).
- 40-40. Route ground cable (74) to shunt (13).
- 40-41. Route cable (72) from shunt (13) to rear battery. Secure cables (72) and (74) with screw (73).
- 40-42. Route cable (31) from shunt (13) to terminal block. Secure cables (75) and (31) to shunt (13) with screw (76).
- 40-43. Route cable (77) from solenoid (21) to negative terminal.
- 40-44. Route cable (71) from solenoid (21) to rear battery. Secure cables (71) and (77) to solenoid (21) with nut (70).
- 40-45. Secure cable (30) to solenoid (21) with washer (67) and nut (68).
- 40-46. Route cable (78) from solenoid (21) to negative terminal.
- 40-47. Secure cable (78) to solenoid (21) with nut (69).



- 58. EPLRS POWER CABLE – A3004939 – QTY. 1
- 59. UPPER SINCGARS POWER CABLE – A3014039-2 – QTY. 1
- 60. LOOP CLAMP – MS21333-75 – QTY. 1
- 61. SELF-TAPPING SCREW – 9421073 – QTY. 1
- 64. POWER CABLE (NTDR) – 8174912-2 – QTY. 1
- 65. LOWER SINCGARS POWER CABLE – A3014039-2 – QTY. 1

Figure 5-135.



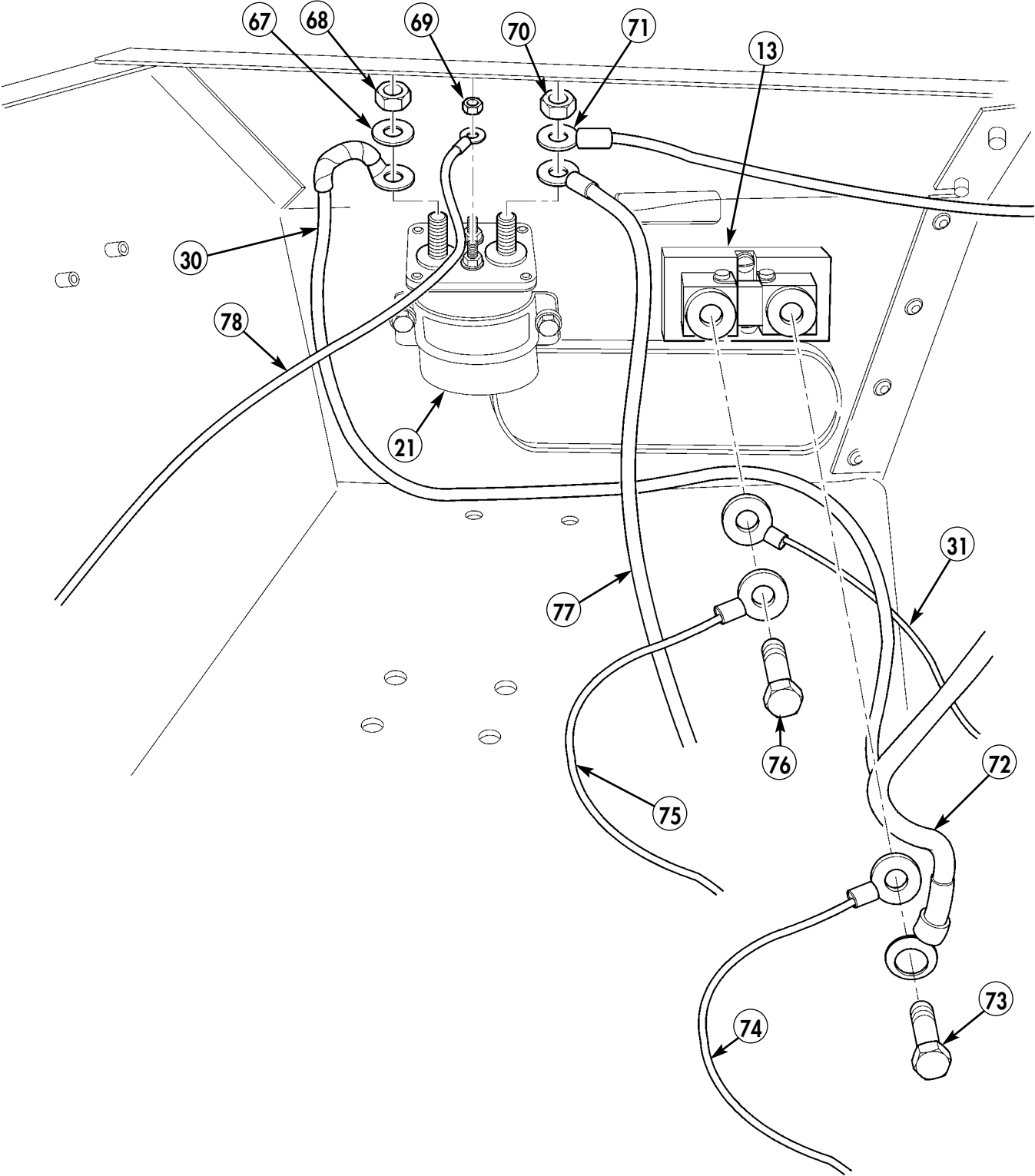

Figure 5-136.

- 40-48. Connect black charger cable (79) under antenna bracket (80) to power entry box (81).
- 40-49. Route black charger cable (79) from power entry box (81) along top of wheelwell (83). Secure with existing clamps (84) and self-tapping screws (82).
- 40-50. Route black charger cable (79) down front of wheelwell (83). Secure with existing clamps (85) and self-tapping screws (91).
- 40-51. Route black charger cable (79) along C-beam (90). Secure with existing clamp (87), screw (86), lockwasher (88), and nut (89).

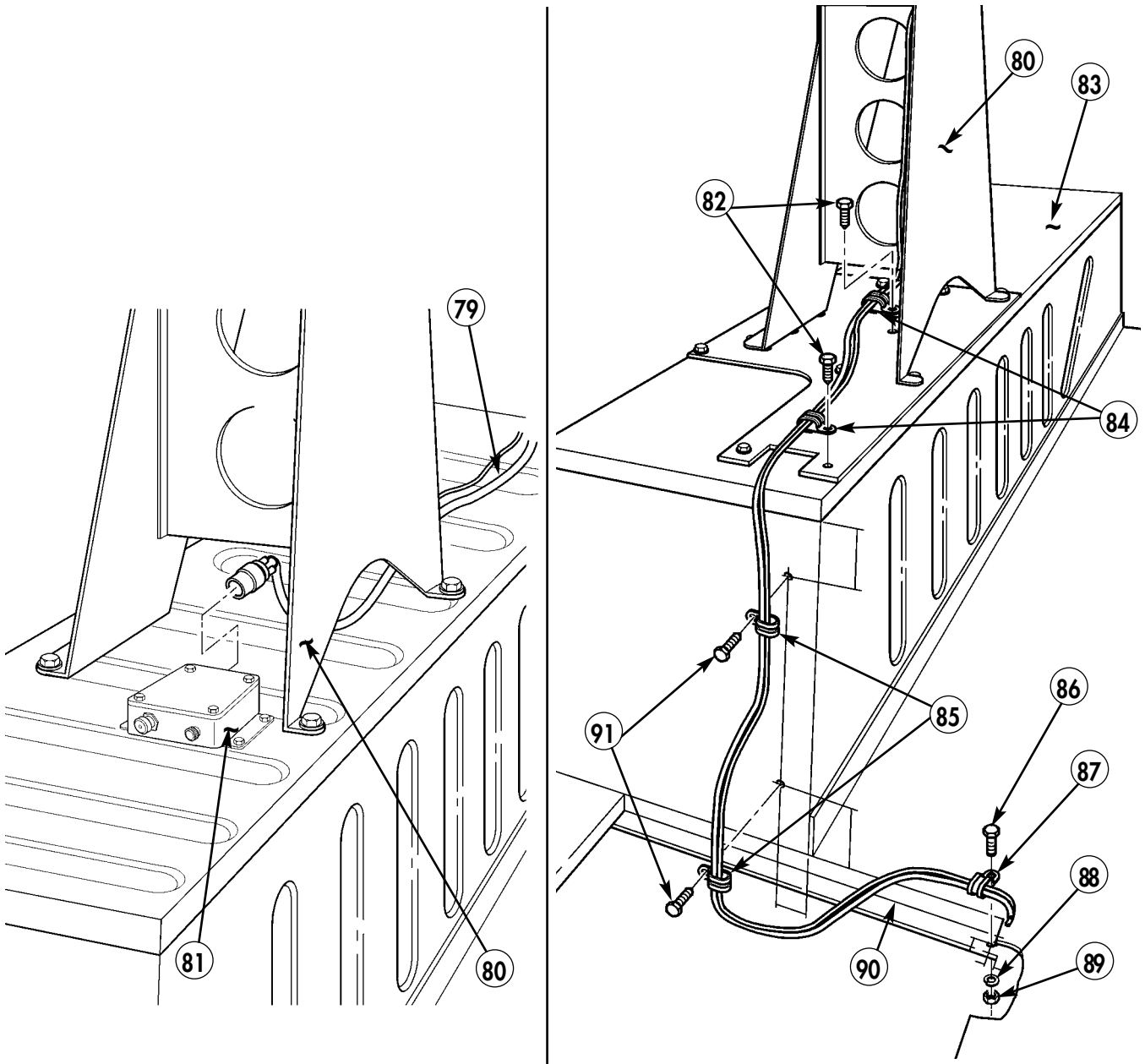

Figure 5-137.

40-52. Route black charger cable (79) through hole (63) in frame (62).

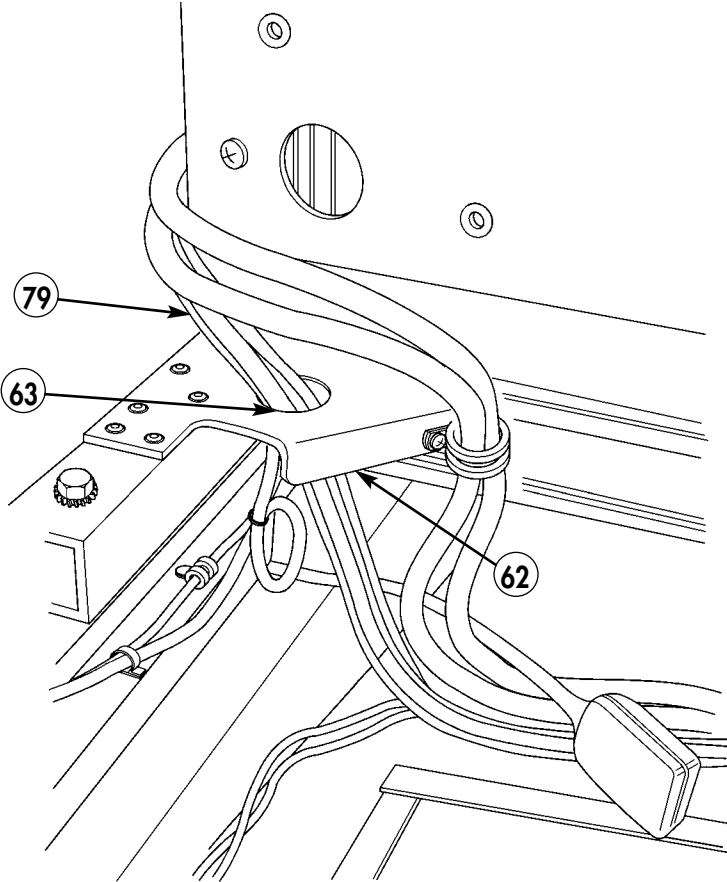
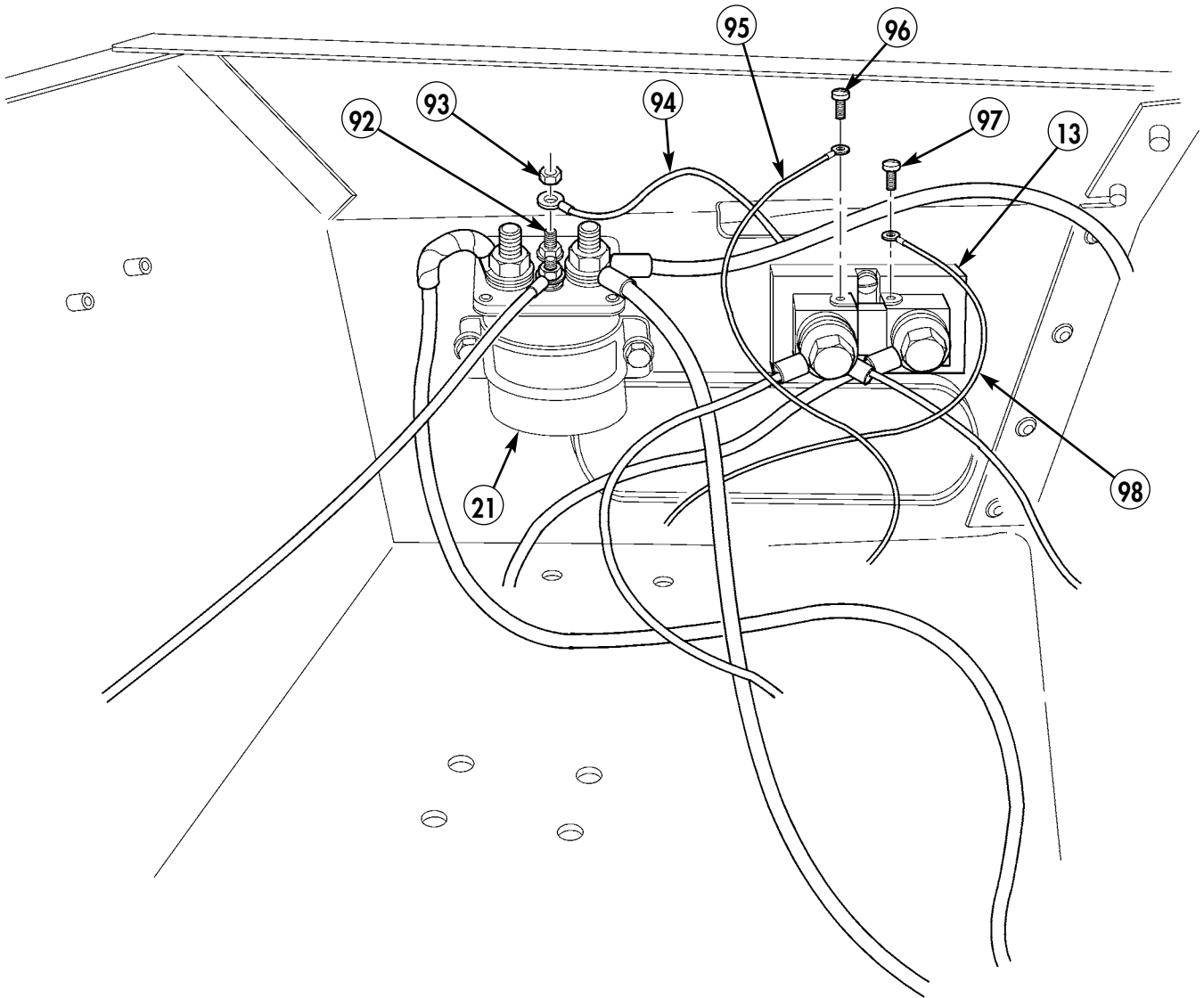

Figure 5-138.

- 40-53. Route red cable (94) from stud (92) of solenoid (21) to control box. Secure cable (94) to solenoid (21) with nut (93).
- 40-54. Route green cable (95) from shunt (13) to control box. Secure green cable (95) to shunt (13) with screw (96).
- 40-55. Route orange cable (98) from shunt (13) to control box. Secure orange cable (98) to shunt (13) with screw (97).



- 94. CABLE (CONTROL BOX, RED) – N/A – QTY.1
- 95. CABLE (CONTROL BOX, GREEN) – N/A – QTY.1
- 98. CABLE (CONTROL BOX, ORANGE) – N/A – QTY.1

Figure 5-139.

- 40-56. Attach shrink tubing (117) and terminal lug (115) to NTDR positive power terminal (134). Secure to terminal board stud (99) with existing nut (116).
- 40-57. Attach shrink tubing (117) and terminal lug (115) to NTDR negative power terminal (124). Secure to terminal board stud (108) with existing nut (116).
- 40-58. Attach shrink tubing (117) and terminal lug (115) to EPLRS positive power terminal (133). Secure to terminal board stud (100) with existing nut (116).
- 40-59. Attach shrink tubing (117) and terminal lug (115) to EPLRS negative power terminal (123). Secure to terminal board stud (109) with existing nut (116).
- 40-60. Attach shrink tubing (117) and terminal lug (115) to lower SINCGARS positive power terminal (132). Secure to terminal board stud (101) with existing nut (116).
- 40-61. Attach shrink tubing (117) and terminal lug (115) to lower SINCGARS negative power terminal (122). Secure to terminal board stud (110) with existing nut (116).
- 40-62. Attach shrink tubing (117) and terminal lug (115) to front SINCGARS positive power terminal (131). Secure to terminal board stud (102) with existing nut (116).
- 40-63. Attach shrink tubing (117) and terminal lug (115) to front SINCGARS negative power terminal (121). Secure to terminal board stud (111) with existing nut (116).
- 40-64. Attach shrink tubing (117) and terminal lug (115) to DAGR positive power terminal (130). Secure to terminal board stud (103) with existing nut (116).
- 40-65. Attach shrink tubing (117) and terminal lug (115) to DAGR negative power terminal (120). Secure to terminal board stud (112) with existing nut (116).
- 40-66. Attach shrink tubing (117) and terminal lug (115) to white control cable positive terminal (128). Secure to terminal board stud (105) with existing nut (116).
- 40-67. Attach shrink tubing (117) and terminal lug (115) to black control cable negative terminal (118). Secure to terminal board stud (114) with existing nut (116).
- 40-68. Attach shrink tubing (117) and terminal lug (115) to upper SINCGARS positive power terminal (127). Secure to terminal board stud (106) with existing nut (116).
- 40-69. Attach shrink tubing (117) and terminal lug (115) to upper SINCGARS negative power terminal (125). Secure to terminal board stud (108) with existing nut (116).
- 40-70. Attach shrink tubing (117) and terminal lug (115) to solenoid to positive power terminal (129). Secure to terminal board stud (104) with existing nut (116).
- 40-71. Attach shrink tubing (117) and terminal lug (115) to shunt to negative terminal (126). Secure to terminal board stud (107) with existing nut (116).
- 40-72. Attach shrink tubing (117) and terminal lug (115) to solenoid to negative terminal (119). Secure to terminal board stud (113) with existing nut (116).

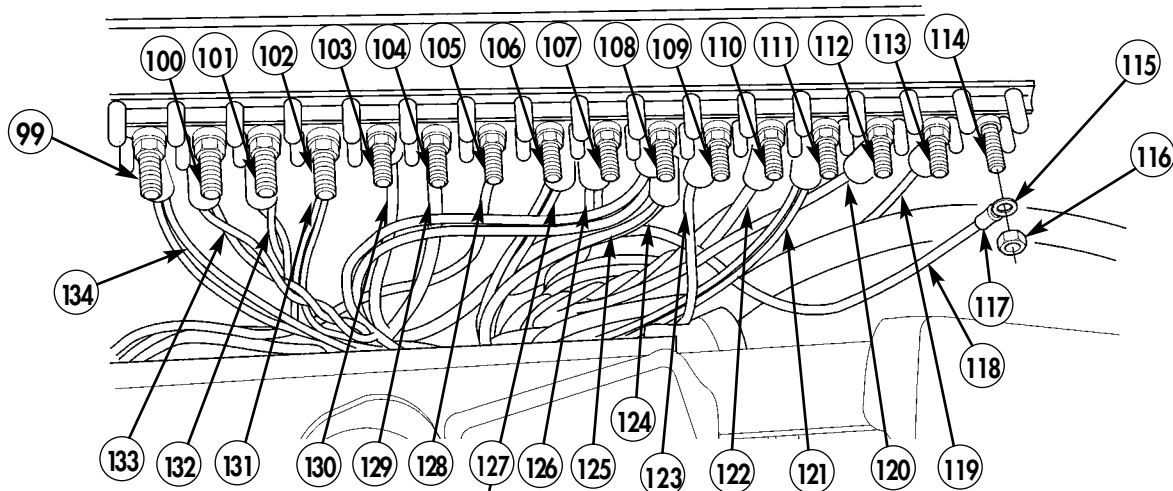

117. SHRINK TUBING - MS23053/4-302-0 - QTY. A/R

Figure 5-140.

40-73. Bundle cables and secure with tiedown straps (135).

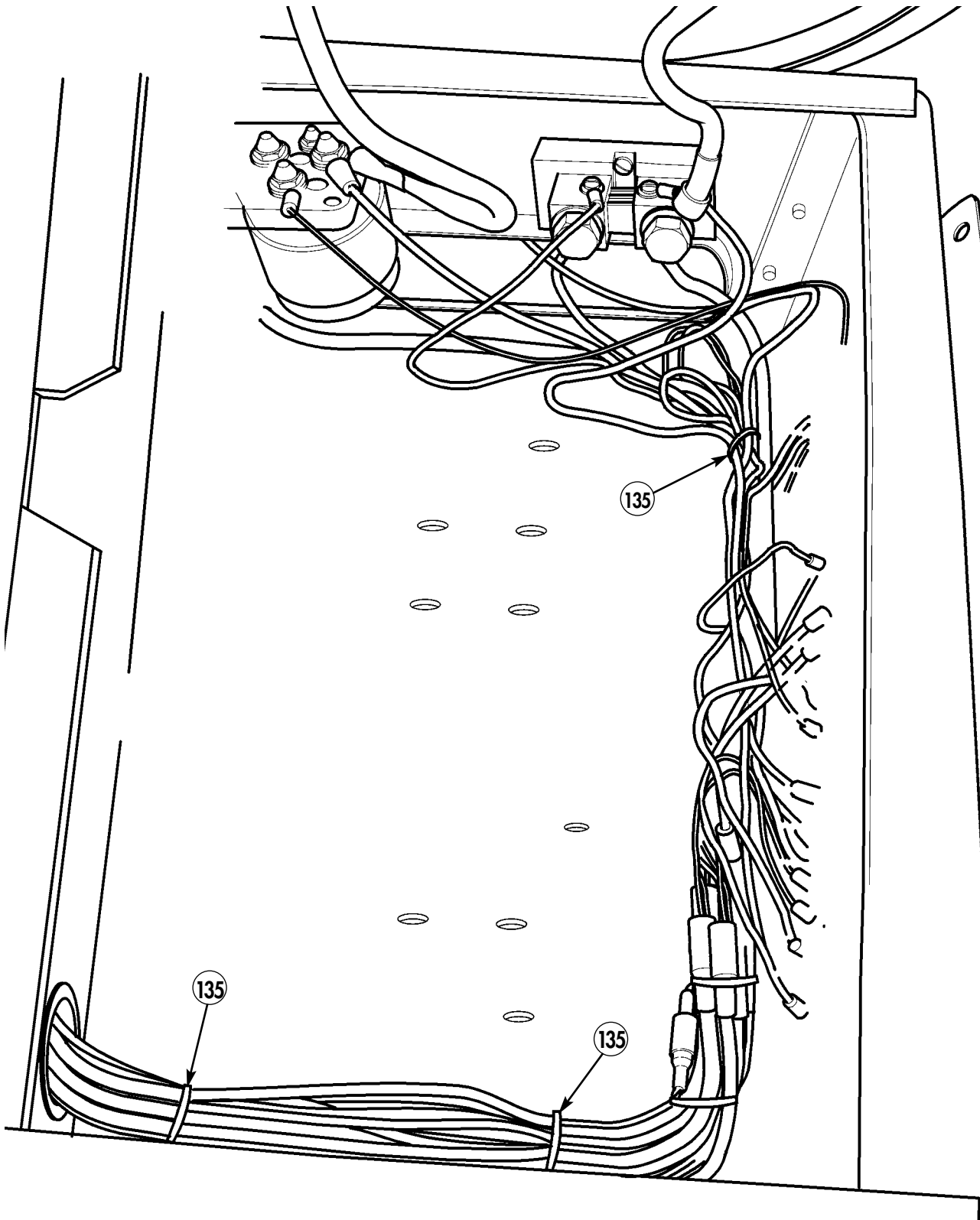

135. TIEDOWN STRAP – MS3367-1-0 – QTY. A/R

Figure 5-141.

**40-74.** Route four charger power cables (136), (137), (138), and (139) through hole (63) in frame (62), along tunnel (27), and into battery box (3). Secure cables with tiedown strap (135).

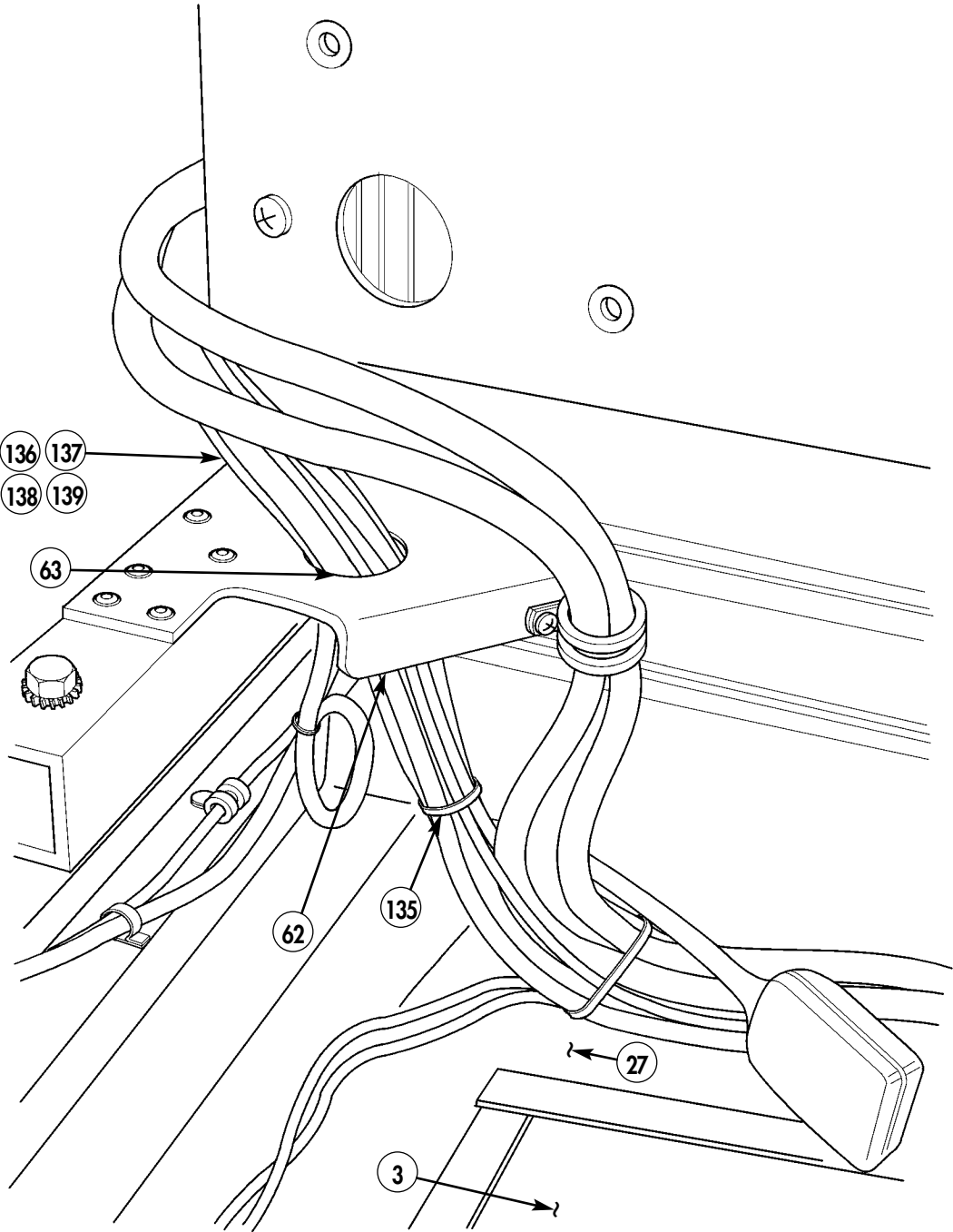

**135. TIEDOWN STRAP – MS3367-1-0 – QTY. A/R**

*Figure 5-142.*

- 40-75. Install left-side supplemental battery (140) and right-side supplemental battery (145) on battery support plate (37).
- 40-76. Install battery connector plate (143) on existing studs (144) with two washers (142) and nuts (141).
- 40-77. Install battery hold-down plate (146) on J-bolts (38) with two washers (142) and nuts (141).

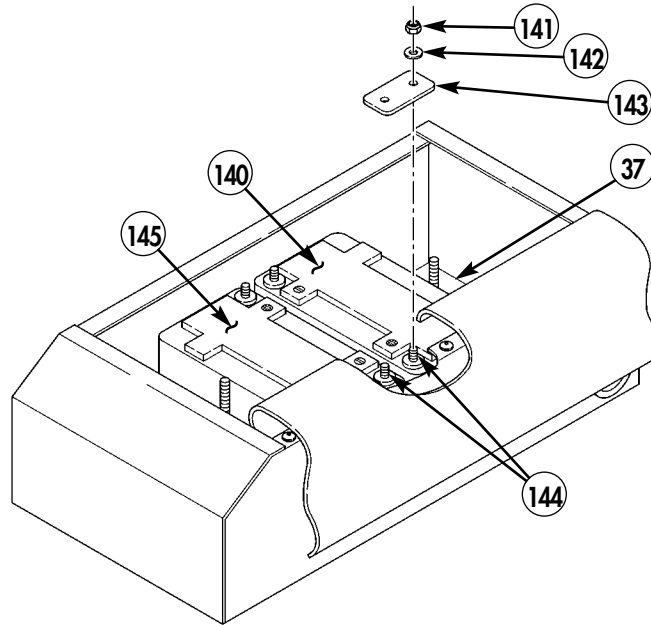
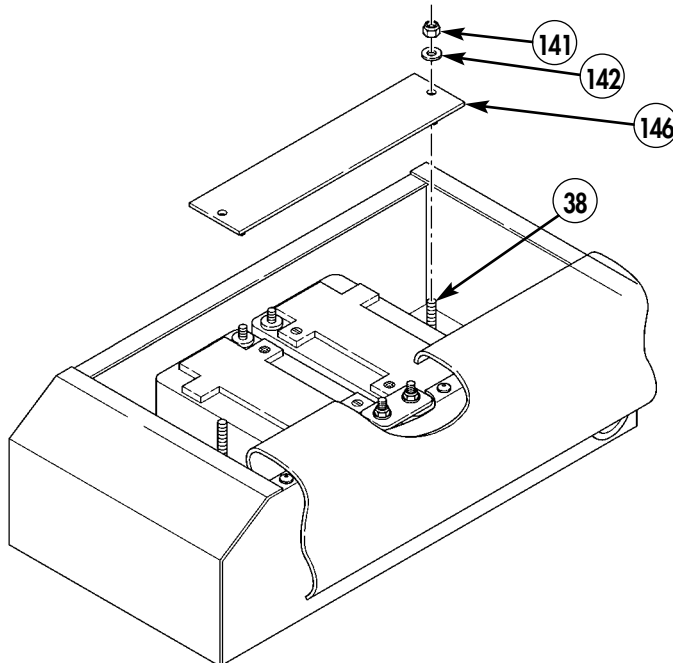

Figure 5-143.



146. BATTERY HOLD-DOWN PLATE – 03A0103D – QTY. 1

Figure 5-144.



**NOTE**

Two charger cables connect to each battery. Connect positive and negative leads respectively.

- 40-78. Connect charger cable positive leads (149) to left and right rear batteries (140) and (145).
- 40-79. Connect charger cable negative leads (153) to left and right rear batteries (140) and (145).
- 40-80. Connect shunt cable (148) to left rear battery (140).
- 40-81. Connect solenoid cable (147) to right rear battery (145).
- 40-82. Connect ground cable (152) to left rear battery (140).
- 40-83. Secure cables to batteries (145) and (140) with washers (150) and nuts (151).

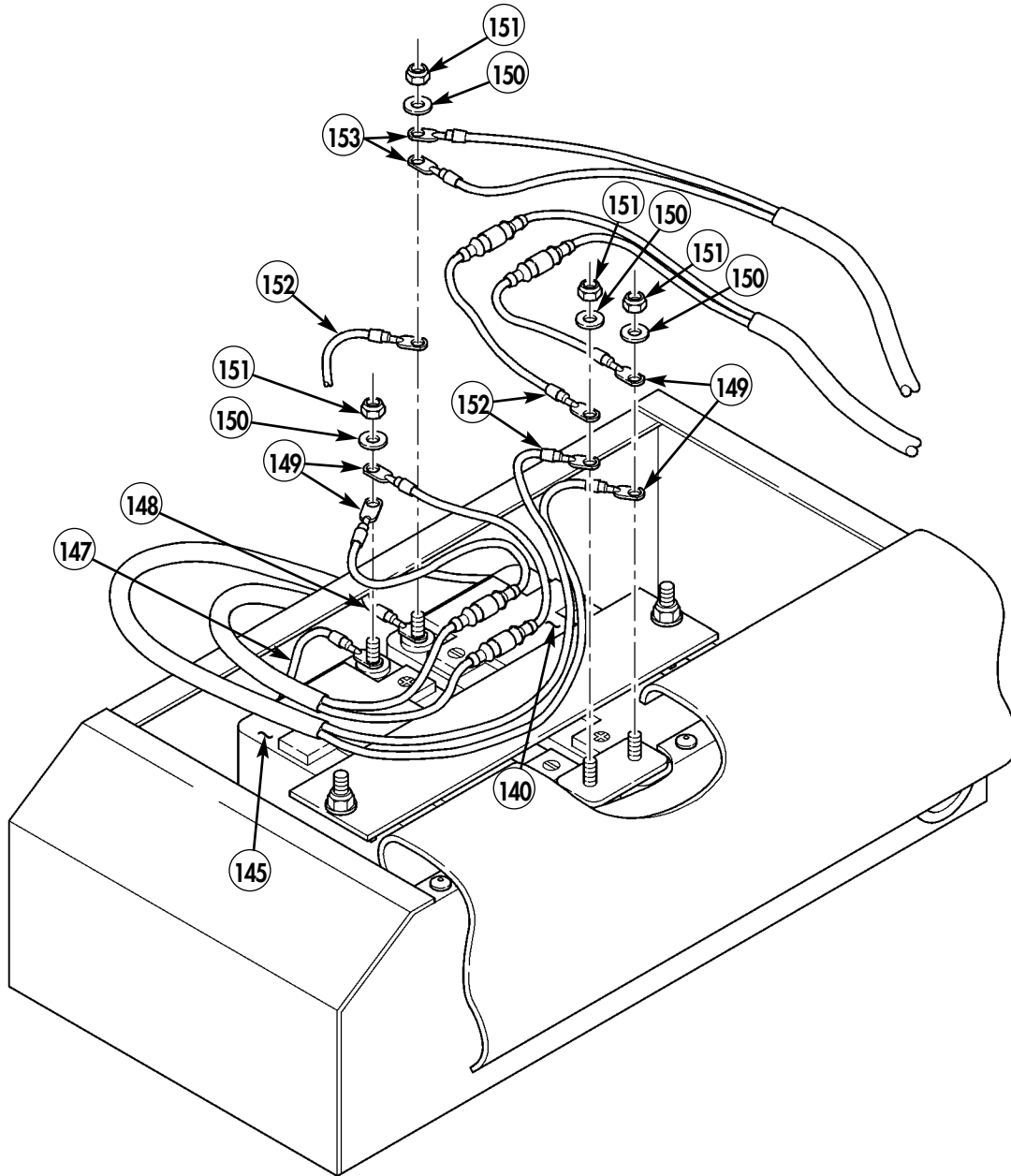
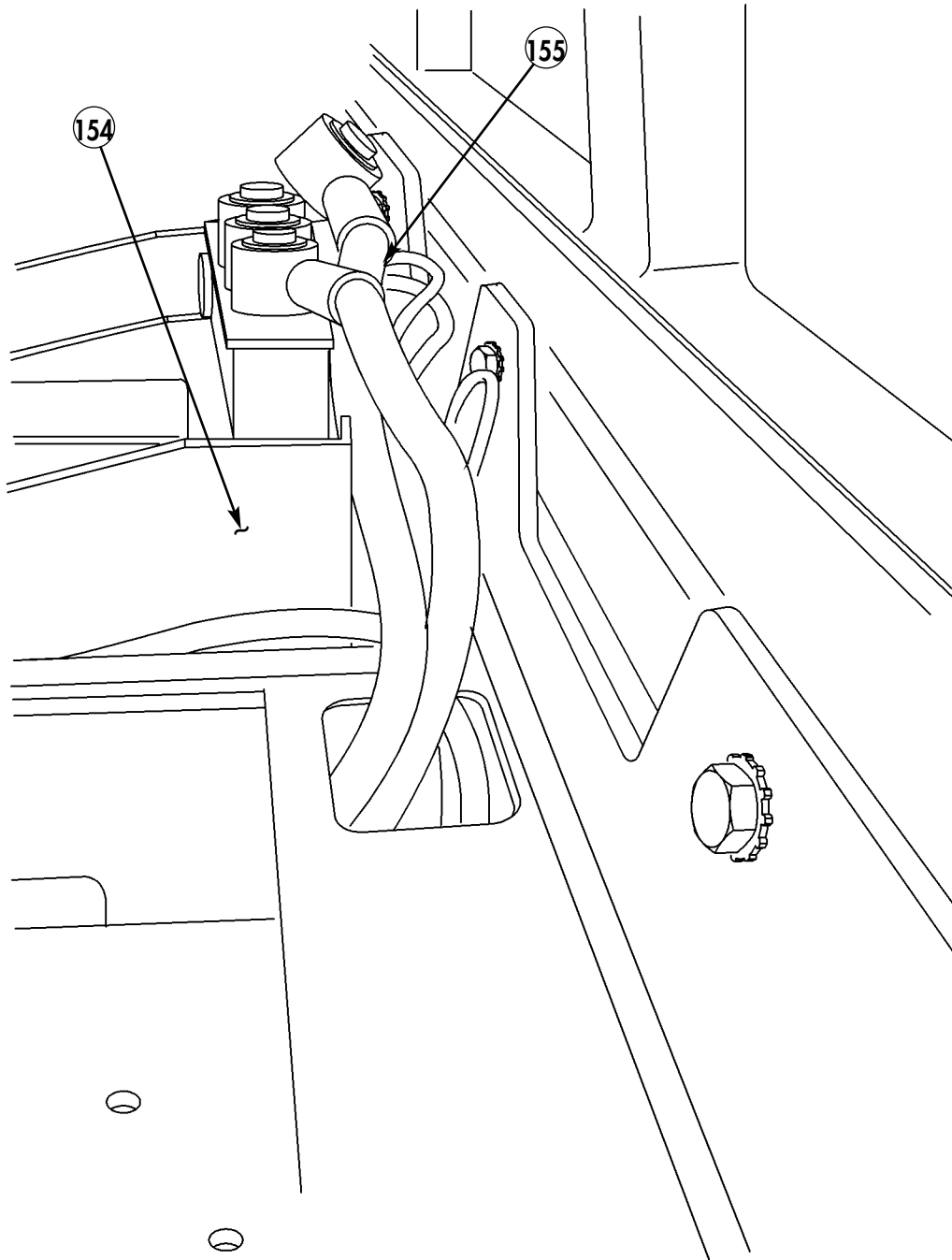

Figure 5-145.

- 147. CABLE (SOLENOID TO REAR BATTERY) – RCSK 19644 – QTY. 1
- 148. CABLE (SHUNT TO REAR BATTERY) – RCSK 19643 – QTY. 1

40-84. Route SINCGARS power cable (155) to MT-6353/VRC mounting base (154).



155. SINCGARS POWER CABLE – A3014039-7 – QTY. 1

Figure 5-146.

**40-85.** Install terminal cover (156) on terminal block (7). Secure terminal cover (156) to terminal block (7) with nuts (157).

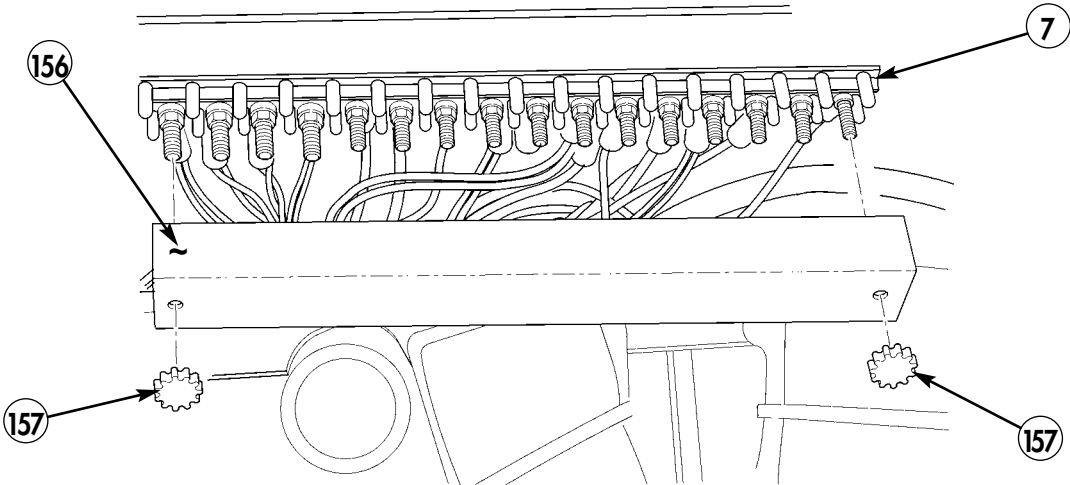

**156. TERMINAL COVER – MS18029-IL-16 – QTY. 1**

*Figure 5-147.*

**NOTE**

- Bundle any excess cable with tiedown straps and place behind multi-net rack.
- Cut convoluted tubing to length, approximately 34 inches and 9.5 inches.

**40-86.** Install convoluted tubing (158) over cabling with tiedown straps (135).

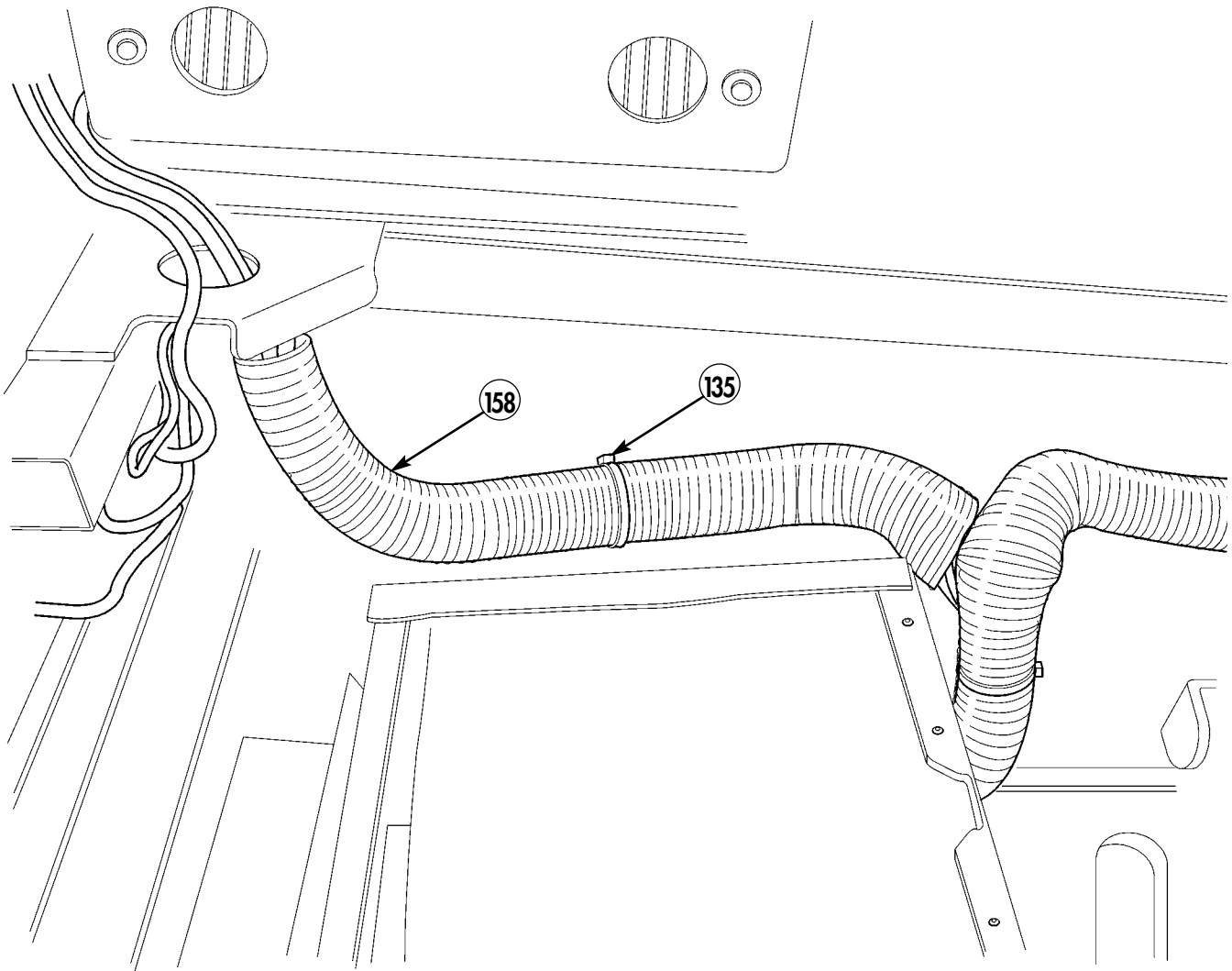

**158. CONVOLUTED TUBING – N/A – QTY. A/R**

*Figure 5-148.*

By Order of the Secretary of the Army:

PETER J. SCHOOMAKER  
*General, United States Army*  
*Chief of Staff*

Official:

A handwritten signature in black ink that reads "Joyce E. Morrow". The signature is written in a cursive, flowing style.

JOYCE E. MORROW  
*Administrative Assistant to the*  
*Secretary of the Army*  
0615302

Distribution:

To be distributed in accordance with the Initial Distribution Number (IDN) 344855 requirements for TB 9-2320-280-35-15.



<b>RECOMMENDED CHANGES TO PUBLICATIONS AND BLANK FORMS</b> For use of this form, see AR 25-30; the proponent agency is ODISC4.	Use Part II (reverse) for Repair Parts and Special Tools Lists (RPSTL) and Supply Catalogs/Supply Manuals (SC/SM).	<b>DATE:</b> <p style="text-align: center;"><b>6 October 2006</b></p>
---	--	--

<b>TO: (Forward to proponent of publication or form) (include ZIP code)</b> AMSTA-LC-LPIT/Tech Pubs, TACOM-RI 1 Rock Island Arsenal Rock Island, IL 61299-7630	<b>FROM: (Activity and location) (include ZIP code)</b> <p style="text-align: center;"><b>Co. B, 1st BN, 2nd Brigade Ft. Hood, TX 76445</b></p>
---	--

PART I - ALL PUBLICATIONS (EXCEPT RPSTL AND SC/SM) AND BLANK FORMS

<b>PUBLICATION/FORM NUMBER</b> <p style="text-align: center;">TB 9-2320-280-35-15</p>	<b>DATE</b> <p style="text-align: center;">29 SEP. 2006</p>	<b>TITLE</b> <p style="text-align: center;"><b>TECHNICAL BULLETIN INSTALLATION INSTRUCTIONS</b></p>
--	--	--

ITEM NO.	PAGE NO.	PARA-GRAPH	LINE NO.*	FIGURE NO.	TABLE NO.	RECOMMENDED CHANGES AND REASON <i>(Provide exact wording of recommended changes, if possible)</i>
----------	----------	------------	-----------	------------	-----------	--

1	5-52	26	26-3	5-60		<p><b>We are using screw MS35207-265 to install power entry box.</b></p>
---	------	----	------	------	--	--

SAMPLE

*\*Reference to line numbers within the paragraph or subparagraph.*

<b>TYPED NAME, GRADE, OR TITLE</b> <p style="text-align: center;"><b>Pat Smith</b></p>	<b>TELEPHONE EXCHANGE/AUTOVON, PLUS EXTENSION</b> <p style="text-align: center;"><b>AV272-4162</b></p>	<b>SIGNATURE</b> <p style="text-align: center;"><i>Pat Smith</i></p>
---	---	---

TO: <i>(Forward direct to addressee listed in publication)</i> AMSTA-LC-LPIT/Tech Pubs, TACOM-RI 1 Rock Island Arsenal Rock Island, IL 61299-7630	FROM: <i>(Activity and location) (include ZIP code)</i>	DATE: <b>6 October 2006</b>
--	---	--------------------------------

PART II - REPAIR PARTS AND SPECIAL TOOLS LISTS AND SUPPLY CATALOGS/SUPPLY MANUALS

PUBLICATION/FORM NUMBER <b>TB 9-2320-280-35-15</b>	DATE <b>29 SEP. 2006</b>	TITLE <b>TECHNICAL BULLETIN INSTALLATION INSTRUCTIONS</b>
---	-----------------------------	--

PAGE NO.	COLM NO.	LINE NO.	NATIONAL STOCK NUMBER	REFERENCE NO.	FIGURE NO.	ITEM NO.	TOTAL NO. OF MAJOR ITEMS SUPPORTED	RECOMMENDED ACTION
<b>SAMPLE</b>								

PART III - REMARKS *(Any general remarks or recommendations, or suggestions for improvement of publications and blank forms. Additional blank sheets may be used if more space is needed.)*

TYPED NAME, GRADE, OR TITLE	TELEPHONE EXCHANGE/AUTOVON, PLUS EXTENSION	SIGNATURE
-----------------------------	--	-----------



<b>RECOMMENDED CHANGES TO PUBLICATIONS AND BLANK FORMS</b> For use of this form, see AR 25-30; the proponent agency is ODISC4.				Use Part II (reverse) for Repair Parts and Special Tools Lists (RPSTL) and Supply Catalogs/Supply Manuals (SC/SM).		DATE:
TO: (Forward to proponent of publication or form) (include ZIP code) <b>AMSTA-LC-LPIT/Tech Pubs, TACOM-RI</b> 1 Rock Island Arsenal Rock Island, IL 61299-7630				FROM: (Activity and location) (include ZIP code)		
PART I - ALL PUBLICATIONS (EXCEPT RPSTL AND SC/SM) AND BLANK FORMS						
PUBLICATION/FORM NUMBER <b>TB 9-2320-280-35-15</b>			DATE <b>29 SEP. 2006</b>		TITLE <b>TECHNICAL BULLETIN INSTALLATION INSTRUCTIONS</b>	
ITEM NO.	PAGE NO.	PARA-GRAPH	LINE NO.*	FIGURE NO.	TABLE NO.	RECOMMENDED CHANGES AND REASON <i>(Provide exact wording of recommended changes, if possible)</i>
<i>*Reference to line numbers within the paragraph or subparagraph.</i>						
TYPED NAME, GRADE, OR TITLE				TELEPHONE EXCHANGE/AUTOVON, PLUS EXTENSION		SIGNATURE

TO: <i>(Forward direct to addressee listed in publication)</i> AMSTA-LC-LPIT/Tech Pubs, TACOM-RI 1 Rock Island Arsenal Rock Island, IL 61299-7630	FROM: <i>(Activity and location) (include ZIP code)</i>	DATE:
--	---	-------

PART II - REPAIR PARTS AND SPECIAL TOOLS LISTS AND SUPPLY CATALOGS/SUPPLY MANUALS

PUBLICATION/FORM NUMBER  TB 9-2320-280-35-15	DATE  29 SEP. 2006	TITLE  TECHNICAL BULLETIN INSTALLATION INSTRUCTIONS
--	--------------------------	--

PAGE NO.	COLM NO.	LINE NO.	NATIONAL STOCK NUMBER	REFERENCE NO.	FIGURE NO.	ITEM NO.	TOTAL NO. OF MAJOR ITEMS SUPPORTED	RECOMMENDED ACTION

PART III - REMARKS *(Any general remarks or recommendations, or suggestions for improvement of publications and blank forms. Additional blank sheets may be used if more space is needed.)*

--

TYPED NAME, GRADE, OR TITLE	TELEPHONE EXCHANGE/AUTOVON, PLUS EXTENSION	SIGNATURE

<b>RECOMMENDED CHANGES TO PUBLICATIONS AND BLANK FORMS</b> For use of this form, see AR 25-30; the proponent agency is ODISC4.	Use Part II (reverse) for Repair Parts and Special Tools Lists (RPSTL) and Supply Catalogs/Supply Manuals (SC/SM).	<b>DATE:</b>
---	--	--------------

<b>TO:</b> <i>(Forward to proponent of publication or form) (include ZIP code)</i>  <b>AMSTA-LC-LPIT/Tech Pubs, TACOM-RI</b> 1 Rock Island Arsenal Rock Island, IL 61299-7630	<b>FROM:</b> <i>(Activity and location) (include ZIP code)</i>
---	--

**PART I - ALL PUBLICATIONS (EXCEPT RPSTL AND SC/SM) AND BLANK FORMS**

<b>PUBLICATION/FORM NUMBER</b>  TB 9-2320-280-35-15	<b>DATE</b>  29 SEP. 2006	<b>TITLE</b>  TECHNICAL BULLETIN INSTALLATION INSTRUCTIONS
---	---------------------------------	---

ITEM NO.	PAGE NO.	PARA-GRAPH	LINE NO.*	FIGURE NO.	TABLE NO.	<b>RECOMMENDED CHANGES AND REASON</b> <i>(Provide exact wording of recommended changes, if possible)</i>

*\*Reference to line numbers within the paragraph or subparagraph.*

<b>TYPED NAME, GRADE, OR TITLE</b>	<b>TELEPHONE EXCHANGE/AUTOVON, PLUS EXTENSION</b>	<b>SIGNATURE</b>
------------------------------------	---	------------------

<b>TO:</b> <i>(Forward direct to addressee listed in publication)</i> AMSTA-LC-LPIT/Tech Pubs, TACOM-RI 1 Rock Island Arsenal Rock Island, IL 61299-7630	<b>FROM:</b> <i>(Activity and location) (include ZIP code)</i>	<b>DATE:</b>
---	--	--------------

PART II - REPAIR PARTS AND SPECIAL TOOLS LISTS AND SUPPLY CATALOGS/SUPPLY MANUALS

<b>PUBLICATION/FORM NUMBER</b> TB 9-2320-280-35-15	<b>DATE</b> 29 SEP. 2006	<b>TITLE</b> TECHNICAL BULLETIN INSTALLATION INSTRUCTIONS
---	-----------------------------	---

PAGE NO.	COLM NO.	LINE NO.	NATIONAL STOCK NUMBER	REFERENCE NO.	FIGURE NO.	ITEM NO.	TOTAL NO. OF MAJOR ITEMS SUPPORTED	RECOMMENDED ACTION

**PART III - REMARKS** *(Any general remarks or recommendations, or suggestions for improvement of publications and blank forms. Additional blank sheets may be used if more space is needed.)*

--

<b>TYPED NAME, GRADE, OR TITLE</b>	<b>TELEPHONE EXCHANGE/AUTOVON, PLUS EXTENSION</b>	<b>SIGNATURE</b>

<b>RECOMMENDED CHANGES TO PUBLICATIONS AND BLANK FORMS</b> For use of this form, see AR 25-30; the proponent agency is ODISC4.				Use Part II (reverse) for Repair Parts and Special Tools Lists (RPSTL) and Supply Catalogs/Supply Manuals (SC/SM).		DATE:
TO: <i>(Forward to proponent of publication or form) (include ZIP code)</i> AMSTA-LC-LPIT/Tech Pubs, TACOM-RI 1 Rock Island Arsenal Rock Island, IL 61299-7630				FROM: <i>(Activity and location) (include ZIP code)</i>		
PART I - ALL PUBLICATIONS (EXCEPT RPSTL AND SC/SM) AND BLANK FORMS						
PUBLICATION/FORM NUMBER TB 9-2320-280-35-15			DATE 29 SEP. 2006		TITLE TECHNICAL BULLETIN INSTALLATION INSTRUCTIONS	
ITEM NO.	PAGE NO.	PARA-GRAPH	LINE NO.*	FIGURE NO.	TABLE NO.	RECOMMENDED CHANGES AND REASON <i>(Provide exact wording of recommended changes, if possible)</i>
<i>*Reference to line numbers within the paragraph or subparagraph.</i>						
TYPED NAME, GRADE, OR TITLE				TELEPHONE EXCHANGE/AUTOVON, PLUS EXTENSION		SIGNATURE

<b>TO:</b> <i>(Forward direct to addressee listed in publication)</i> AMSTA-LC-LPIT/Tech Pubs, TACOM-RI 1 Rock Island Arsenal Rock Island, IL 61299-7630	<b>FROM:</b> <i>(Activity and location) (include ZIP code)</i>	<b>DATE:</b>
---	--	--------------

PART II - REPAIR PARTS AND SPECIAL TOOLS LISTS AND SUPPLY CATALOGS/SUPPLY MANUALS

<b>PUBLICATION/FORM NUMBER</b> TB 9-2320-280-35-15	<b>DATE</b> 29 SEP. 2006	<b>TITLE</b> TECHNICAL BULLETIN INSTALLATION INSTRUCTIONS
---	-----------------------------	---

PAGE NO.	COLM NO.	LINE NO.	NATIONAL STOCK NUMBER	REFERENCE NO.	FIGURE NO.	ITEM NO.	TOTAL NO. OF MAJOR ITEMS SUPPORTED	RECOMMENDED ACTION

**PART III - REMARKS** *(Any general remarks or recommendations, or suggestions for improvement of publications and blank forms. Additional blank sheets may be used if more space is needed.)*

--

<b>TYPED NAME, GRADE, OR TITLE</b>	<b>TELEPHONE EXCHANGE/AUTOVON, PLUS EXTENSION</b>	<b>SIGNATURE</b>



